

INSTRUCTION MANUAL

MAVERICK[®] 260X

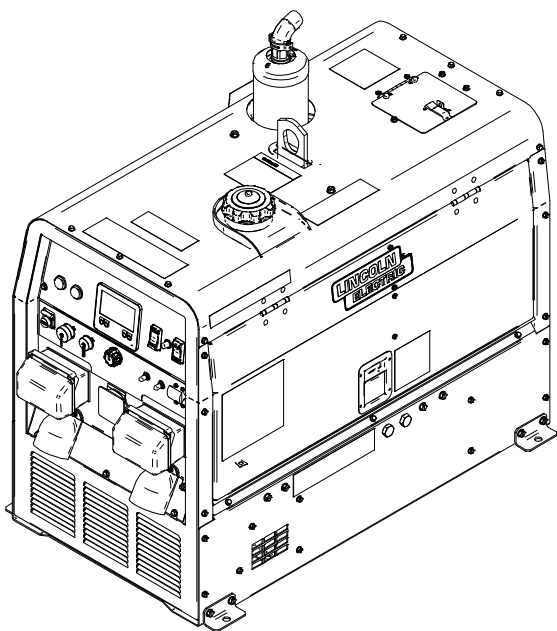

For use with Product/Code
Numbers:
13228

Save for future reference

Date Purchased

Code: (ex: 10859)

Serial: (ex: U1060512345)

Contents

INSTALLATION..... SECTION A

| | |
|---|------|
| GRAPHIC SYMBOLS..... | A-1 |
| TECHNICAL SPECIFICATION..... | A-3 |
| SAFETY PRECAUTIONS..... | A-4 |
| VRD (VOLTAGE REDUCTION DEVICE)..... | A-5 |
| LOCATION AND VENTALATION..... | A-6 |
| STORING..... | A-7 |
| STACKING..... | A-7 |
| ANGLE OF OPERATION..... | A-7 |
| LIFTING..... | A-7 |
| HIGH ALTITUDE OPERATION..... | A-8 |
| HIGH TEMPERATURE OPERATION..... | A-8 |
| TOWING..... | A-8 |
| VEHICLE MOUNTING..... | A-9 |
| PRE-OPERATION ENGINE SERVICE..... | A-9 |
| OIL..... | A-9 |
| FUEL - USE DIESEL FUEL ONLY..... | A-9 |
| ENGINE COOLANT..... | A-10 |
| BATTERY CONNECTION..... | A-10 |
| MUFFLER OUTLET PIPE..... | A-11 |
| SPARK ARRESTOR..... | A-11 |
| CASE FRONT CONTROLS..... | A-12 |
| WELDING TERMINALS..... | A-13 |
| WELDING OUTPUT CABLES..... | A-13 |
| MACHINE GROUNDING..... | A-14 |
| REMOTE CONTROL..... | A-14 |
| STANDBY POWER CONNECTIONS..... | A-15 |
| CABLE INDUCTANCE AND ITS EFFECTS ON WELDING..... | A-15 |
| WIRE WELDING SET-UP..... | A-16 |
| AUXILIARY POWER RECEPTACLES..... | A-18 |
| AUXILIARY POWER..... | A-18 |
| CONNECTION OF ACROSS THE ARC WIRE FEEDERS TO THE MAVERICK 260X..... | A-18 |
| ELECTRICAL DEVICE USE WITH THIS PRODUCT..... | A-20 |

OPERATION..... SECTION B

| | |
|----------------------------------|------|
| SAFETY PRECAUTIONS..... | B-1 |
| GENERAL DESCRIPTION..... | B-2 |
| FOR AUXILIARY POWER..... | B-2 |
| ENGINE OPERATION CHECK..... | B-2 |
| ADD FUEL..... | B-2 |
| FUEL PUMP WITH PRIMER LEVER..... | B-3 |
| RECOMMENDED APPLICATIONS..... | B-4 |
| GENERATOR..... | B-4 |
| AUTO-START INSTRUCTION..... | B-4 |
| BREAK-IN PERIOD..... | B-5 |
| ENGINE OPERATION..... | B-5 |
| TYPICAL FUEL CONSUMPTION..... | B-6 |
| WELDER OPERATION..... | B-6 |
| PARALLELING..... | B-10 |
| AUXILIARY POWER OPERATION..... | B-10 |

| | |
|---|------|
| SIMULTANEOUS WELDING AND AUXILIARY POWER LOADS..... | B-11 |
| DISPLAY OPERATION..... | B-11 |
| HOME SCREEN..... | B-12 |
| STICK WELDING..... | B-13 |
| MIG/FCAW WELDING..... | B-15 |
| CROSSLINC..... | B-16 |
| SPOOL GUN..... | B-17 |
| SPOOL GUN SYNERGIC CONTROL MODE..... | B-18 |
| SPOOL GUN PULSE MODE..... | B-18 |
| SPOT TIME MODE..... | B-19 |
| ENGINE STATUS SCREEN..... | B-20 |
| ENGINE INFORMATION..... | B-21 |
| SET-UP..... | B-21 |
| MACHINE SELECT..... | B-23 |
| SPOOL GUN CALIBRATION..... | B-24 |
| ENGINE SERVICE KIT..... | B-25 |
| PRODUCTIVITY METRICS..... | B-26 |

ACCESSORIES AND OPTIONS..... SECTION C

| | |
|--------------------------------|-----|
| MAVERICK 260X ACCESSORIES..... | C-1 |
|--------------------------------|-----|

MAINTENANCE..... SECTION D

| | |
|--|-----|
| SAFETY PRECAUTIONS..... | D-1 |
| ROUTINE AND PERIODIC MAINTENANCE..... | D-1 |
| ENGINE MAINTENANCE..... | D-1 |
| AIR FILTER..... | D-2 |
| AIR FILTER SERVICE INSTRUCTIONS..... | D-3 |
| FUEL FILTERS..... | D-5 |
| COOLING SYSTEM..... | D-5 |
| NAMEPLATES / WARNING DECALS MAINTENANCE..... | D-5 |
| WELDER / GENERATOR MAINTENANCE..... | D-5 |
| FAN BELT CHANGE..... | D-6 |
| OIL CHANGE..... | D-7 |
| BATTERY HANDLING..... | D-7 |
| PREVENTING ELECTRICAL DAMAGE..... | D-8 |
| PREVENTING BATTERY DISCHARGE..... | D-8 |
| PREVENTING BATTERY BUCKLING..... | D-8 |
| CHARGING THE BATTERY..... | D-8 |
| WELDER GENERATOR MAINTENANCE..... | D-8 |
| BRUSH REMOVAL AND REPLACEMENT..... | D-9 |

TROUBLESHOOTING..... SECTION E

| | |
|---------------------------------------|-----|
| HOW TO USE TROUBLESHOOTING GUIDE..... | E-1 |
| TROUBLESHOOTING GUIDE..... | E-2 |

WIRING DIAGRAM

DIMENSION PRINT

CUSTOMER ASSISTANCE POLICY

SAFETY INFORMATION

SAFETY DEPENDS ON YOU

Lincoln welding and cutting equipment is designed and built with safety in mind. However, your overall safety can be increased by proper installation ... and thoughtful operation on your part. **DO NOT INSTALL, OPERATE OR REPAIR THIS EQUIPMENT WITHOUT READING THIS MANUAL AND THE SAFETY PRECAUTIONS CONTAINED THROUGHOUT.** And, most importantly, think before you act and be careful.

|  DANGER | |
|---|---|
|  | This statement indicates an imminently hazardous situation which, if not avoided, will result in death or serious injury. |

|  WARNING | |
|--|--|
|  | This statement indicates a potentially hazardous situation which, if not avoided, could result in death or serious injury. |

|  CAUTION | |
|--|---|
|  | This statement indicates a potentially hazardous situation which, if not avoided, could result in minor or moderate injury. |

Notice: This statement indicates the possibility of damage to equipment if the potential risk is not avoided.

PLEASE EXAMINE CARTON AND EQUIPMENT FOR DAMAGE IMMEDIATELY

When this equipment is shipped, title passes to the purchaser upon receipt by the carrier. Consequently, claims for material damaged in shipment must be made by the purchaser against the transportation company at the time the shipment is received.

KEEP YOUR HEAD OUT OF THE FUMES



- **DON'T** get too close to the weld. Use corrective lenses if necessary to stay a reasonable distance away from the weld.
- **USE ENOUGH VENTILATION** or exhaust at the weld, or both, to keep the fumes and gases from your breathing zone and the general area.
- **IN A LARGE ROOM OR OUTDOORS**, natural ventilation may be adequate if you keep your head out of the fumes.
- **USE NATURAL DRAFTS** or fans to keep the fumes away from your face.
- **READ** and obey the Safety Data Sheet (SDS) and the warning label that appears on all containers of welding materials.

If you develop unusual symptoms, see your supervisor. Perhaps the welding atmosphere and ventilation system should be checked.

WEAR CORRECT EYE, EAR AND BODY PROTECTION



- **PROTECT** your eyes and face with properly fitted and with proper grade of filter plate (See ANSI Z49.1).
- **PROTECT** your body from welding spatter and arc flash with protective clothing including woolen clothing, flame-proof apron and gloves, leather leggings, and high boots.
- **PROTECT** others from spatter, flash, and glare with protective screens or barriers.
- **PROTECT** your eyes and face with welding helmet
- **IN SOME AREAS**, protection from noise may be appropriate.
- **BE SURE** protective equipment is in good condition.
- **AT ALL TIMES**, wear safety glasses in work area.



- **DO NOT WELD OR CUT** containers or materials which previously had been in contact with hazardous substances unless they are properly cleaned. This is extremely dangerous.



SAFETY INFORMATION



- **DO NOT WELD OR CUT** painted or plated parts unless special precautions with ventilation have been taken. They can release highly toxic fumes or gases.
- **PROTECT** compressed gas cylinders from excessive heat, mechanical shocks, and arcs; fasten cylinders so they cannot fall.
- **BE SURE** cylinders are never grounded or part of an electrical circuit.
- **REMOVE** all potential fire hazards from welding area.



- **ALWAYS HAVE FIRE FIGHTING EQUIPMENT READY FOR IMMEDIATE USE AND KNOW HOW TO USE IT.**

CALIFORNIA PROPOSITION 65 WARNINGS

|  WARNING | |
|--|---|
|  | <p>Breathing diesel engine exhaust exposes you to chemicals known to the State of California to cause cancer and birth defects, or other reproductive harm.</p> <p>Always start and operate the engine in a well-ventilated area.</p> <p>If in an exposed area, vent the exhaust to the outside.</p> <p>Do not modify or tamper with the exhaust system.</p> <p>Do not idle the engine except as necessary.</p> |

|  WARNING | |
|--|--|
|  | <p>This product, when used for welding or cutting, produces fumes or gases which contain chemicals known to the State of California to cause birth defects and, in some cases, cancer. (California Health & Safety Code § 25249.5 et seq.)</p> |

For more information go to <https://www.p65warnings.ca.gov>

ARC WELDING CAN BE HAZARDOUS

PROTECT YOURSELF AND OTHERS FROM POSSIBLE SERIOUS INJURY OR DEATH. KEEP CHILDREN AWAY. PACEMAKER WEARERS SHOULD CONSULT WITH THEIR DOCTOR BEFORE OPERATING.

Read and understand the following safety highlights. For additional safety information, it is strongly recommended that you purchase a copy of "Safety in Welding & Cutting - ANSI Standard Z49.1" from the American Welding Society, P.O. Box 351040, Miami, Florida 33135 or CSA Standard W117.2. A Free copy of "Arc Welding Safety" booklet E205 is available from the Lincoln Electric Company, 22801 St. Clair Avenue, Cleveland, Ohio 44117-1199.

BE SURE THAT ALL INSTALLATION, OPERATION, MAINTENANCE AND REPAIR PROCEDURES ARE PERFORMED ONLY BY QUALIFIED INDIVIDUALS.

FOR ENGINE POWERED EQUIPMENT



- Turn the engine off before troubleshooting and maintenance work unless the maintenance work requires it to be running.



- Do not add the fuel near an open flame welding arc or when the engine is running. Stop the engine and allow it to cool before refueling to prevent spilled fuel from vaporizing on contact with hot engine parts and igniting. Do not spill fuel when filling tank. If fuel is spilled, wipe it up and do not start engine until fumes have been eliminated.



- Keep all equipment safety guards, covers and devices in position and in good repair. Keep hands, hair, clothing and tools away from V-belts, gears, fans and all other moving parts when starting, operating or repairing equipment.

- In some cases it may be necessary to remove safety guards to perform required maintenance. **REMOVE GUARDS ONLY** when necessary and replace them when the maintenance requiring their removal is complete. Always use the greatest care when working near moving parts.
- **DO NOT** put your hands near the engine fan. Do not attempt to override the governor or idler by pushing on the throttle control rods while the engine is running.
- To prevent accidentally starting gasoline engines while turning the engine or welding generator during maintenance work, disconnect the spark plug wires, distributor cap or magneto wire as appropriate.



- To avoid scalding, do not remove the radiator pressure cap when the engine is hot.



- Generator exhaust contains carbon monoxide. This is a poison you cannot see or smell.
- Using a generator indoors **CAN KILL YOU IN MINUTES**.
- **NEVER** use inside a home or garage, **EVEN IF** doors and windows are open.
- **ONLY** use **OUTSIDE** and far away from windows, doors and vents.



- Avoid other generator hazards. **READ MANUAL BEFORE USE.**

ELECTRIC AND MAGNETIC FIELDS MAY BE DANGEROUS



- Electric current flowing through any conductor causes localized Electric and Magnetic Fields (EMF). Welding current creates EMF fields around welding cables and welding machines.
- EMF fields may interfere with some pacemakers, and welders having a pacemaker should consult their physician before welding.
- Exposure to EMF fields in welding may have other health effects which are now not known. All welders should use the following procedures in order to minimize exposure to EMF fields from the welding circuit:
- Route the electrode and work cables together - Secure them with tape when possible.

- Never coil the electrode lead around your body.
- Do not place your body between the electrode and work cables. If the electrode cable is on your right side, the work cable should also be on your right side.
- Connect the work cable to the workpiece as close as possible to the area being welded.
- Do not work next to welding power source.

ELECTRIC SHOCK CAN KILL



- The electrode and work (or ground) circuits are electrically "hot" when the welder is on. Do not touch these "hot" parts with your bare skin or wet clothing. Wear dry, hole-free gloves to insulate hands.
- Insulate yourself from work and ground using dry insulation. Make certain the insulation is large enough to cover your full area of physical contact with work and ground.

In addition to the normal safety precautions, if welding must be performed under electrically hazardous conditions (in damp locations or while wearing wet clothing; on metal structures such as floors, gratings or scaffolds; when in cramped positions such as sitting, kneeling or lying, if there is a high risk of unavoidable or accidental contact with the workpiece or ground) use the following equipment:

- Semiautomatic DC Constant Voltage (Wire) Welder.
- DC Manual (Stick) Welder.
- AC Welder with Reduced Voltage Control.
- In semiautomatic or automatic wire welding, the electrode, electrode reel, welding head, nozzle or semiautomatic welding gun are also electrically "hot".
- Always be sure the work cable makes a good electrical connection with the metal being welded. The connection should be as close as possible to the area being welded.
- Ground the work or metal to be welded to a good electrical (earth) ground.
- Maintain the electrode holder, work clamp, welding cable and welding machine in good, safe operating condition. Replace damaged insulation.
- Never dip the electrode in water for cooling.

SAFETY INFORMATION

- Never simultaneously touch electrically “hot” parts of electrode holders connected to two welders because voltage between the two can be the total of the open circuit voltage of both welders.
- When working above floor level, use a safety belt to protect yourself from a fall should you get a shock.
- **Also see [WELDING AND CUTTING SPARKS CAN CAUSE FIRE OR EXPLOSION](#) and [FOR ELECTRICALLY POWERED EQUIPMENT](#)**

ARC RAYS CAN BURN



- Use a shield with the proper filter and cover plates to protect your eyes from sparks and the rays of the arc when welding or observing open arc welding. Headshield and filter lens should conform to ANSI Z87.1 standards.
- Use suitable clothing made from durable flame-resistant material to protect your skin and that of your helpers from the arc rays.
- Protect other nearby personnel with suitable, non-flammable screening and/or warn them not to watch the arc nor expose themselves to the arc rays or to hot spatter or metal.

FUMES AND GASES CAN BE DANGEROUS



- Welding may produce fumes and gases hazardous to health. Avoid breathing these fumes and gases. When welding, keep your head out of the fume. Use enough ventilation and/or exhaust at the arc to keep fumes and gases away from the breathing zone.
- **When welding hardfacing (see instructions on container or SDS) or on lead or cadmium plated steel and other metals or coatings which produce highly toxic fumes, keep exposure as low as possible and within applicable OSHA PEL and ACGIH TLV limits using local exhaust or mechanical ventilation unless exposure assessments indicate otherwise. In confined spaces or in some circumstances, outdoors, a respirator may**

also be required. Additional precautions are also required when welding on galvanized steel.

- The operation of welding fume control equipment is affected by various factors including proper use and positioning of the equipment, maintenance of the equipment and the specific welding procedure and application involved. Worker exposure level should be checked upon installation and periodically thereafter to be certain it is within applicable OSHA PEL and ACGIH TLV limits.
- Do not weld in locations near chlorinated hydrocarbon vapors coming from degreasing, cleaning or spraying operations. The heat and rays of the arc can react with solvent vapors to form phosgene, a highly toxic gas, and other irritating products.
- Shielding gases used for welding can displace air and cause injury or death. Always use enough ventilation, especially in confined areas, to insure breathing air is safe.
- Read and understand the manufacturer’s instructions for this equipment and the consumables to be used, including the Safety Data Sheet (SDS) and follow your employer’s safety practices. SDS forms are available from your welding distributor or from the manufacturer.
- Also see [FOR ENGINE POWERED EQUIPMENT](#)

WELDING AND CUTTING SPARKS CAN CAUSE FIRE OR EXPLOSION



- Remove fire hazards from the welding area. If this is not possible, cover them to prevent the welding sparks from starting a fire. Remember that welding sparks and hot materials from welding can easily go through small cracks and openings to adjacent areas. Avoid welding near hydraulic lines. Have a fire extinguisher readily available.
- Where compressed gases are to be used at the job site, special precautions should be used to prevent hazardous situations. Refer to “**Safety in Welding and Cutting**” (ANSI Standard Z49.1) and the operating information for the equipment being used.

- When not welding, make certain no part of the electrode circuit is touching the work or ground. Accidental contact can cause overheating and create a fire hazard.
- Do not heat, cut or weld tanks, drums or containers until the proper steps have been taken to ensure that such procedures will not cause flammable or toxic vapors from substances inside. They can cause an explosion even though they have been “cleaned”. For information, purchase “Recommended Safe Practices for the Preparation for Welding and Cutting of Containers and Piping That Have Held Hazardous Substances”, **AWS F4.1** from the American Welding Society.
- Vent hollow castings or containers before heating, cutting or welding. They may explode.
- Sparks and spatter are thrown from the welding arc. Wear oil free protective garments such as leather gloves, heavy shirt, cuff-less trousers, high shoes and a cap over your hair. Wear ear plugs when welding out of position or in confined places. Always wear safety glasses with side shields when in a welding area.
- Connect the work cable to the work as close to the welding area as practical. Work cables connected to the building framework or other locations away from the welding area increase the possibility of the welding current passing through lifting chains, crane cables or other alternate circuits. This can create fire hazards or overheat lifting chains or cables until they fail.
- **Read and follow NFPA 51B** “Standard for Fire Prevention During Welding, Cutting and Other Hot Work”, available from NFPA, 1 Batterymarch Park, PO box 9101, Quincy, MA 02269-9101.
- **DO NOT** use a welding power source for pipe thawing.

CYLINDER MAY EXPLODE IF DAMAGED



- Use only compressed gas cylinders containing the correct shielding gas for the process used and properly operating regulators designed for the gas and pressure used. All hoses, fittings, etc. should be suitable for the application and maintained in good condition.

- Always keep cylinders in an upright position securely chained to an undercarriage or fixed support.

Cylinders should be located:

- Away from areas where they may be struck or subjected to physical damage.
- A safe distance from arc welding or cutting operations and any other source of heat, sparks, or flame.
- Never allow the electrode, electrode holder or any other electrically “hot” parts to touch a cylinder.
- Keep your head and face away from the cylinder valve outlet when opening the cylinder valve.
- Valve protection caps should always be in place and hand tight except when the cylinder is in use or connected for use.
- Read and follow the instructions on compressed gas cylinders, associated equipment, and CGA publication P-1, “Precautions for Safe Handling of Compressed Gases in Cylinders,” available from the Compressed Gas Association, 14501 George Carter Way Chantilly, VA 20151.

FOR ELECTRICALLY POWERED EQUIPMENT



- Turn off input power using the disconnect switch at the fuse box before working on the equipment.
- Install equipment in accordance with the U.S. National Electrical Code, all local codes and the manufacturer’s recommendations.
- Ground the equipment in accordance with the U.S. National Electrical Code and the manufacturer’s recommendations.

BATTERY HANDLING, STORAGE, AND DISPOSAL



Batteries can be flammable substances such as lithium or other organic solvents, which may result in overheating, rupture, or combustion. Failure to follow the battery manufactures instructions may result in fire, personal injury, and damage to property if used improperly.

SAFETY INFORMATION

- DO NOT short circuit, disassemble, deform, or heat batteries.
- DO NOT attempt to recharge batteries unless they are specifically marked as "rechargeable".
- DO NOT use or charge the battery if it appears to be leaking, deformed or damaged in any way.
- Store in a cool location. Keep batteries away from direct sunlight, high temperature, and high humidity.
- Immediately discontinue use of the battery if, while using, charging, or storing the battery, the battery emits an unusual smell, feels hot, changes color, changes shape, or appears abnormal in any other way.
- Keep batteries out of reach of children, should a child swallow a battery, consult a physician immediately.
- Recycle or dispose of batteries in accordance with local and federal laws.
- All persons inside LCA must wear proper PPE to avoid eye or skin exposure to laser radiation. The end user's LSO shall select proper PPE including, but not limited to, heat-resistant gloves, flame-resistant clothing, laser safety eye wear and laser-safe helmets that conform to ANSI Z136.1 Optical Density requirements for the wavelength and output power of the laser in use. Standard safety glasses and welding helmets DO NOT provide adequate protection from laser beam hazards. Always inspect PPE for damage or improper fit before use.
- Only qualified persons shall install, operate or service this unit per ANSI Z136.1 standards and your LSO's instruction. Read and follow all labels and manuals before installing, operating, or servicing hand held any laser welding equipment.
- Do not operate outside of a LCA, or if the laser protective housing is modified or damaged, or if safety interlocks have been bypassed or otherwise defeated. Inspect all equipment and LCA for damage or tampering prior to use.
- Reflected beams from the laser can damage eyes and skin and can pose a fire risk. Prior to use, the LCA should be assessed by the LSO to understand the surfaces where hazardous reflected beams can exist. Never position yourself or flammable material in the anticipated laser beam path and take extra precautions when working on reflective materials like aluminum and stainless steel.
- Follow all standards, individual facility or building regulations, and national, state, and local codes.

FOR LASER EMITTING EQUIPMENT



- Hazardous Class 4 (IV) laser products emit invisible, infrared laser radiation which can permanently damage the eye's retina and/or cornea, burn skin, and pose a fire risk. End users shall assign a qualified Laser Safety Officer (LSO) who has the certifications required by applicable law/standards, have a documented Laser Safety Program and have a Laser Controlled Area (LCA) that confirms to ANSI Z136.1 & Z136.9.
- Do not operate laser before end user's LSO has completed a risk assessment and all the prescribed Risk Mitigations measures have been fully implemented. Ensure the laser is operated/demonstrated safely by trained personnel and that the environment surrounding the laser welding cell or laser-controlled area is safe for people nearby when the laser is in operation.
- Never point the laser at yourself or others. Never look directly into a laser aperture, even if wearing full eye protection.

DEALER LOCATOR & PRODUCT REGISTRATION

Register your machine:



<https://www.lincolnelectric.com/register>

Authorized Service and Distributor Locator:

<https://www.lincolnelectric.com/locator>

ADDITIONAL SAFETY INFORMATION

Refer to <http://www.lincolnelectric.com/safety> for additional safety information



ELECTROMAGNETIC COMPATIBILITY (EMC)

Conformance

Products displaying the CE mark are in conformity with European Community Council Directive of 15 Dec 2004 on the approximation of the laws of the Member States relating to electromagnetic compatibility, 2004/108/EC. It was manufactured in conformity with a national standard that implements a harmonized standard: EN 60974-10 Electromagnetic Compatibility (EMC) Product Standard for Arc Welding Equipment. It is for use with other Lincoln Electric equipment. It is designed for industrial and professional use.

Introduction

All electrical equipment generates small amounts of electromagnetic emission. Electrical emission may be transmitted through power lines or radiated through space, similar to a radio transmitter. When emissions are received by other equipment, electrical interference may result. Electrical emissions may affect many kinds of electrical equipment; other nearby welding equipment, radio and TV reception, numerical controlled machines, telephone systems, computers, etc.

|  WARNING | |
|--|---|
|  | This Class A equipment is not intended for use in residential locations where the electrical power is provided by the public low-voltage supply system. There may be potential difficulties in ensuring electro-magnetic compatibility in those locations, due to conducted as well as radiated disturbances. |

Installation and Use

The user is responsible for installing and using the welding equipment according to the manufacturer's instructions. If electromagnetic disturbances are detected then it shall be the responsibility of the user of the welding equipment to resolve the situation with the technical assistance of the manufacturer. In some cases this remedial action may be as simple as earthing (grounding) the welding circuit, see Note. In other cases it could involve constructing an electromagnetic screen enclosing the power source and the work complete with associated input filters. In all cases electromagnetic disturbances must be reduced to the point where they are no longer troublesome.

Note: The welding circuit may or may not be earthed for safety reasons. Follow your local and national standards for installation and use. Changing the earthing arrangements should only be authorized by a person who is competent to assess whether the changes will increase the risk of injury, e.g., by allowing parallel welding current return paths which may damage the earth circuits of other equipment.

Assessment of area

Before installing welding equipment the user shall make an assessment of potential electromagnetic problems in the surrounding area. The following shall be taken into account:

1. other supply cables, control cables, signaling and telephone cables; above, below and adjacent to the welding equipment;
2. radio and television transmitters and receivers;
3. computer and other control equipment;
4. safety critical equipment, e.g., guarding of industrial equipment;
5. the health of the people around, e.g., the use of pacemakers and hearing aids;
6. equipment used for calibration or measurement;
7. the immunity of other equipment in the environment. The user shall ensure that other equipment being used in the environment is compatible. This may require additional protection measures;

ELECTROMAGNETIC COMPATIBILITY (EMC)

8. the time of day that welding or other activities are to be carried out.

The size of the surrounding area to be considered will depend on the structure of the building and other activities that are taking place. The surrounding area may extend beyond the boundaries of the premises.

Methods of Reducing Emissions

Public Supply System

Welding equipment should be connected to the public supply system according to the manufacturer's recommendations. If interference occurs, it may be necessary to take additional precautions such as filtering of the system. Consideration should be given to shielding the supply cable of permanently installed welding equipment, in metallic conduit or equivalent. Shielding should be electrically continuous throughout its length. The shielding should be connected to the welding power source so that good electrical contact is maintained between the conduit and the welding power source enclosure.

Maintenance of the Welding Equipment

The welding equipment should be routinely maintained according to the manufacturer's recommendations. All access and service doors and covers should be closed and properly fastened when the welding equipment is in operation. The welding equipment should not be modified in any way except for those changes and adjustments covered in the manufacturer's instructions. In particular, the spark gaps of arc striking and stabilizing devices should be adjusted and maintained according to the manufacturer's recommendations.

Welding Cables

The welding cables should be kept as short as possible and should be positioned close together, running at or close to the floor level.

Equipotential Bonding

Bonding of all metallic components in the welding installation and adjacent to it should be considered. However, metallic components bonded to the work piece will increase the risk that the operator could receive a shock by touching these metallic components and the electrode at the same time. The operator should be insulated from all such bonded metallic components.

Earthing of the Workpiece

Where the workpiece is not bonded to earth for electrical safety, nor connected to earth because of its size and position, e.g., ship's hull or building steelwork, a connection bonding the workpiece to earth may reduce emissions in some, but not all instances. Care should be taken to prevent the earthing of the workpiece increasing the risk of injury to users, or damage to other electrical equipment. Where necessary, the connection of the workpiece to earth should be made by a direct connection to the workpiece, but in some countries where direct connection is not permitted, the bonding should be achieved by suitable capacitance, selected according to national regulations.

Screening and Shielding

































Selective screening and shielding of other cables and equipment in the surrounding area may alleviate problems of interference. Screening of the entire welding installation may be considered for special applications¹.

¹Portions of the preceding text are contained in EN 60974-10: "Electromagnetic Compatibility (EMC) product standard for arc welding equipment."































INSTALLATION

GRAPHIC SYMBOLS

The following graphics appear on the machine or in the manual.

| | | | | | |
|---|----------------------|---|----------------------|---|-------------------|
|  | Warning or Caution |  | Hot Surface |  | Earth Ground |
|  | Instructions |  | Fire or explosion |  | Circuit Breaker |
|  | Fumes and Gases |  | Battery explosion |  | Welding Amperage |
|  | Explosion |  | Battery acid |  | Welding Voltage |
|  | Arc Rays |  | System Factory Reset |  | Wire Feed Speed |
|  | Moving Parts |  | Temperature |  | 3 Phase Generator |
|  | Falling Equipment |  | Positive Output |  | Direct Current |
|  | Electric Shock |  | Negative Output |  | Choke |
|  | Open Circuit Voltage |  | SMAW welding |  | Stop |
|  | Output Current |  | GMAW/FCAW welding |  | Auto Idle |
|  | Output Voltage |  | GTAW welding |  | High Idle |

INSTALLATION

| | | | | | |
|---|-------------|---|-----------------------|---|------------|
|  | Duty Cycle |  | Spool Gun |  | Start |
|  | Home |  | Carbon Arc Gouging |  | Select |
|  | Remote |  | Downhill Pipe welding |  | Scroll |
|  | Help |  | Engine |  | Fuel |
|  | Back |  | Set-up |  | CrossLinc |
|  | Oil |  | Hot Start |  | Units |
|  | Air Filter |  | Arc Force |  | Locked |
|  | Spark Plug |  | Pulse |  | Unlocked |
|  | Fuel Filter |  | Spot Time |  | Time |
|  | Brushes |  | Pinch |  | Brightness |
|  | Battery | | | | |

TECHNICAL SPECIFICATION

MAVERICK 260X (K5272-1)

| INPUT - DIESEL ENGINE | | | | | |
|------------------------------|--|--|---|--------------------------------|--|
| MAKE/MODEL | DESCRIPTION | SPEED (RPM) | DISPLACEMENT CU. IN. (LTRS.) | STARTING SYSTEM | DRY CAPACITIES |
| Kubota Z602 | 2 CYLINDER 16.8 HP (12.5 kW) 3600 RPM DIESEL ENGINE | HIGH IDLE 3820 FULL LOAD 3600 LOW IDLE 2650 | 36.55 (0.599) BORE X STROKE INCH (MM) 2.83 X 2.90 (72 X 73.6) | 12 VDC BATTERY & STARTER | FUEL: 12 GAL. (45.4 L) OIL: .66 GAL. (2.5 L) RADIATOR COOLANT: 0.74 GAL. (3.1 L) |

| WELDING RATED OUTPUT @ 104 °F(40 °C) - IEC RATING | | | |
|--|-------------------|---------------------------|----------------------------|
| MODE | DUTY CYCLE | WELDING OUTPUT | VOLTS AT RATED AMPS |
| DC STICK WELDING (CONST. CURRENT) | 100% | 260 A | 30.4 VOLTS |
| DC MIG / FCAW WELDING (CONST. VOLTAGE) | 100% | 282 A | 28.1 VOLTS |
| TOUCH-START TIG | 100% | 300 A | 22 VOLTS |

| WELDING RATED OUTPUT @ 104 °F(40 °C) - OTHER RATING | | |
|--|---------------------------|-----------------------------|
| DUTY CYCLE | WELDING OUTPUT | VOLTS RATED AMPS |
| 100% | 300 A | 26.3 VOLTS |

| OUTPUT @ 104 °F(40 °C) - WELDER AND GENERATOR |
|--|
| WELDING RANGE |
| 30 A - 300 AMPS CC-STICK |
| 30 A - 300 AMPS CC-DOWNHILL PIPE |
| 20 A - 300 AMPS TIG |
| 13 - 40 VOLTS CV-WIRE |
| ARC GOUGING 100 - 300 AMPS |
| OPEN CIRCUIT VOLTAGE |
| 80 MAX OCV @ 3600 RPM |

INSTALLATION

| OUTPUT @ 104 °F(40 °C) - WELDER AND GENERATOR | |
|---|--|
| AUXILIARY POWER | |
| 120 VAC (2) X 2400 WATTS, 60 Hz, SINGLE PHASE | |
| 120/240 VAC x 9000 WATTS, 60 Hz, SINGLE PHASE | |

| PHYSICAL DIMENSIONS | | | |
|-----------------------|--|--------------------------|----------------------|
| HEIGHT | WIDTH | DEPTH | WEIGHT |
| 32.25 IN. (997 MM) | 21.25 IN. ⁽¹⁾ (539.8 MM) | 42.34 IN. (1075.4 MM) | 620 LBS. (281 KG) |

| AGENCY APPROVALS & STANDARDS | |
|------------------------------|---------|
| CONFORMITY MARK | CSA |
| INGRESS PROTECTION RATING | IP23S |
| IEC STANDARD | 60974-1 |

Note: Lift Bale weight rating 1502 lbs. (681 kg) Maximum

Note: ⁽¹⁾ Without trailer mounting brackets installed.

SAFETY PRECAUTIONS

Only qualified personnel should install, use, or service this equipment.

Do not attempt to use this equipment until you have thoroughly read all operating and maintenance manuals supplied with your machine. They include important safety precautions, detailed engine starting, operating and maintenance instructions and parts lists.

| ⚠ WARNING | |
|---|---|
|  | <p>ELECTRIC SHOCK can kill.</p> <ul style="list-style-type: none"> • Do not touch electrically live parts such as output terminals or internal wiring • Insulate yourself from the work and ground. • Always wear dry insulating gloves. |

| ⚠ WARNING | |
|---|--|
|  | <p>ENGINE EXHAUST can kill.</p> <ul style="list-style-type: none"> • Use in open, well ventilated areas or vent exhaust outside |

! WARNING



MOVING PARTS can injure.

- Do not operate with doors open or guards off.
- Stop engine before servicing
- Keep away from moving parts

See additional warning information at front of this operator's manual.

VRD (VOLTAGE REDUCTION DEVICE)

The VRD feature provides additional safety in the Stick, Pipe, TIG and Gouge modes especially in an environment with a higher risk of electric shock such as wet areas and hot humid sweaty conditions.

The VRD reduces the OCV (Open Circuit Voltage) at the welding output terminals while not welding to less than 13 VDC when the resistance of the output circuit is above 200Ω (ohms).

The VRD requires that the welding cable connections be kept in good electrical condition because poor connections will contribute to poor starting. Having good electrical connections also limits the possibility of other safety issues such as heat-generated damage, burns, and fire

While VRD is active, no crossline devices are to be used. Both VRD and crossline are mutually exclusive features.

The machine is shipped with the VRD switch in the "OFF" position. To turn it "ON" or "OFF":

1. Switch the Run - Stop switch to the Stop position.
2. Disconnect the negative battery cable
3. Remove the 4 screws from the case side panel to access the VRD switch on the PC board.

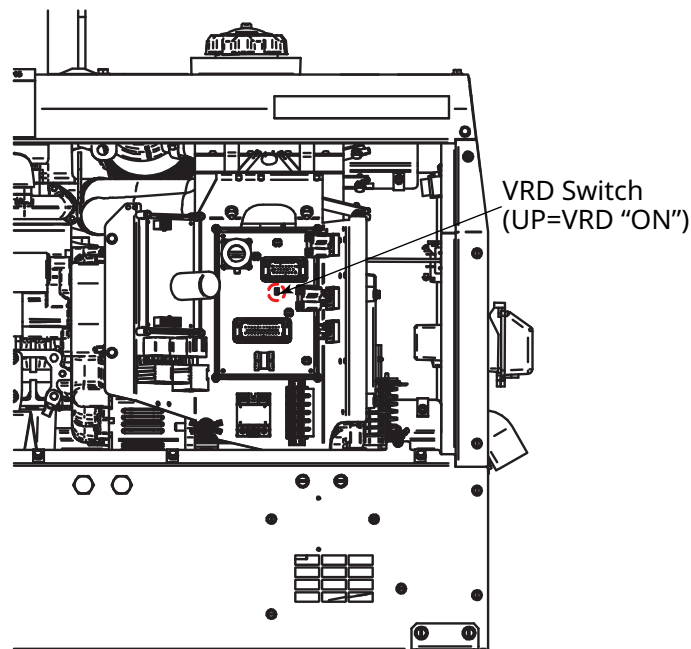

Figure 1 :

INSTALLATION

4. Locate VRD switch (as marked in [Figure 2](#) : on page A-6) on the PC control board.
5. Set VRD switch as desired. Toggle down for "OFF". Toggle up for "ON"
6. Reinstall the case side with screws from Step 3. Turn on the Run switch. Confirm VRD status on the LCD screen display.

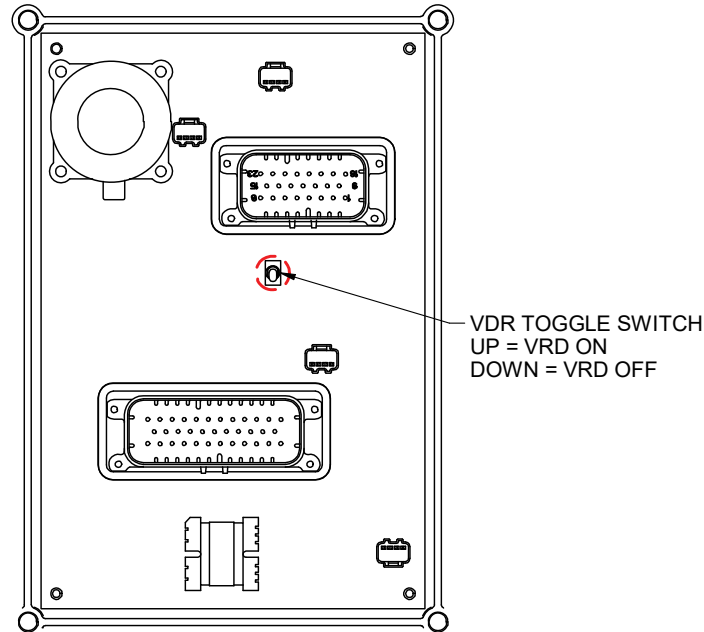

Figure 2 :

When the VRD switch is in the "ON" position. The display will show a green tab with "VOLTS<30". If the VRD switch is in the "ON" position and stud voltage is above 30 volts or while welding, the display will show a red tab with "VOLTS>30".

LOCATION AND VENTILATION

The welder should be located to provide an unrestricted flow of clean, cool air to the cooling air inlets and to avoid restricting the cooling air outlets. Locate the welder so that the engine exhaust fumes are properly vented to an outside area.

CAUTION



DO NOT MOUNT OVER COMBUSTIBLE SURFACES

Where there is a combustible surface directly under stationary or fixed electrical equipment, that surface should be covered with a steel plate at least .06"(1.6mm) thick, which should extend not less than 5.90"(150mm) beyond the equipment on all sides.

Environmental limitations

The MAVERICK 260X is IP23S rated for use in an outdoor environment.

The machine should not be subjected to falling water during use nor should any parts of it be submerged in water. Doing so may cause improper operation as well as pose a safety hazard. The best practice is to keep the machine in a dry, sheltered area.

STORING

1. Store the machine in a cool, dry place when it is not in use. Protect it from dust and dirt. Keep it where it can't be accidentally damaged from construction activities, moving vehicles, and other hazards.
2. Drain the engine oil and refill with fresh oil. Run the engine for about five minutes to circulate oil to all parts. See the [OIL CHANGE](#) on page D-7 section of this manual for details on changing oil.
3. Remove the battery, recharge it, and adjust the electrolyte level. Store the battery in a dry, dark place.

STACKING

MAVERICK 260X machines cannot be stacked.

ANGLE OF OPERATION

To achieve optimum engine performance the MAVERICK 260X should be run in a level position.

Caution: If the welder is placed on a tilted plane, make sure the welder is balanced and secured and 6ft away from an edge to prevent it from toppling over.

The maximum angle of continuous operation for the machine is 35 degrees continuous in all directions.

When operating the welder at an angle, provisions must be made for checking and maintaining the oil level at the normal (FULL) oil capacity. Also the effective fuel capacity will be slightly less than the specified 12 gal. (45.42 ltrs.).

LIFTING

The MAVERICK 260X weighs approximately 705 lbs. (320kg) with a full tank of fuel and 620 lbs. (281kg) without fuel. Lift welder **ONLY** using the lift bail.

WARNING



FALLING EQUIPMENT can cause injury.

- Lift only with equipment of adequate lifting capacity.
- Be sure machine is stable when lifting.
- Do not lift this machine using lift bale if it is equipped with a heavy accessory such as trailer or gas cylinder.
- Do not lift machine if lift bale is damaged.
- Do not operate machine while suspended from lift bale.
- **DO NOT EXCEED MAXIMUM LIFT BAIL WEIGHT RATING.**

See [TECHNICAL SPECIFICATION](#) page.

HIGH ALTITUDE OPERATION

A naturally aspirated engine will run correctly up to an altitude of 600 m (2000 ft.) If the engine is to operate at an altitude above this, an increase in smoke may be seen. This is normal for a naturally aspirated engine. To the right is a table showing the power output loss as the altitude increases. All values in the table are with respect to an ambient temperature of 104°F (40°C).

| ALTITUDE FT (M) | POWER OUTPUT LOSS |
|-----------------|-------------------|
| 0 (0) | 0% |
| 1640 (500) | 5% |
| 3280 (1000) | 10% |
| 4920 (1500) | 14% |
| 6560 (2000) | 18% |
| 8200 (2500) | 22% |
| 9840 (3000) | 26% |
| 11480 (3500) | 30% |

HIGH TEMPERATURE OPERATION

At temperatures above 40°C (104°F), output voltage derating maybe necessary. While operating the MAVERICK 260X continuously (100% Duty Cycle) at an ambient temperature of 40°C, an auxiliary output of 9.0 KW should not be exceeded.

TOWING

If the user adapts a non-Lincoln trailer, he must assume responsibility that the method of attachment and usage does not result in a safety hazard or damage the welding equipment. Some of the factors to be considered are as follows:

1. Design capacity of trailer vs. weight of Lincoln equipment and likely additional attachments.
2. Proper support of, and attachment to, the base of the welding equipment so there will be no undue stress to the framework.
3. Proper placement of the equipment on the trailer to ensure stability side to side and front to back when being moved and when standing by itself while being operated or serviced.
4. Typical conditions of use, i.e., travel speed; roughness of surface on which the trailer will be operated; environmental conditions; like maintenance.
5. Conformance with federal, state and local laws.(1)

Note: (1) Consult applicable federal, state and local laws regarding specific requirements for use on public highways.

VEHICLE MOUNTING

WARNING



Improperly mounted concentrated loads may cause unstable vehicle handling and tires or other components to fail.

- Only transport this Equipment on serviceable vehicles which are rated and designed for such loads.
- Distribute, balance and secure loads so vehicle is stable under conditions of use.
- Do not exceed maximum rated loads for components such as suspension, axles and tires.
- Mount equipment base to metal bed or frame of vehicle.
- Follow vehicle manufacture's instructions.

PRE-OPERATION ENGINE SERVICE

READ the engine operating and maintenance instructions supplied with this machine.

WARNING



Keep hands away from the engine muffler or HOT engine parts.

- Keep hands away from the engine muffler or HOT engine parts.
- Stop engine and allow to cool before fueling.
- Do not smoke when fueling.
- Fill fuel tank at a moderate rate and do not overfill
- Wipe up spilled fuel and allow fumes to clear before starting engine.
- Keep sparks and flame away from tank

OIL

The MAVERICK 260X is shipped with the engine crankcase filled with high quality SAE 10W-30 oil (API class CD or better). Check the engine oil levels before starting the engine. If it is not up to the full mark on the dip stick, add oil as required. Check the oil level every four hours of running time during the First 50 running hours. DO NOT operate with oil below low mark on dipstick. DO NOT fill above full mark on dip stick. Refer to the engine Operator's Manuals for specific oil recommendations and break-in information. The oil change interval is dependent on the quality of the oil and the operating proper service and maintenance intervals.

FUEL - USE DIESEL FUEL ONLY

Low sulphur or ultra low sulphur fuel in US & Canada.

Fill the fuel tank with clean, fresh diesel fuel. The capacity of the fuel tank is approximately 12 gallons (45.42 liters). See engine Operator's Manual for specific fuel recommendations. Running out of fuel may require bleeding the fuel injection pump.

Note: Before starting the engine, open the fuel shutoff valve on the water separator filter located on the lift bale.

ENGINE COOLANT

⚠ WARNING



HOT COOLANT can burn skin.
Do not remove cap if radiator is hot.

The welder is shipped with the engine and radiator filled with a 50% mixture of ethylene glycol and water. See the [ENGINE MAINTENANCE](#) section and the engine Operator's Manual for more information on coolant.

BATTERY CONNECTION

⚠ WARNING



GASES FROM BATTERY can explode.
Keep sparks, flame and cigarettes away from battery.

⚠ WARNING



To prevent EXPLOSION when:

- **INSTALLING A NEW BATTERY** — disconnect negative cable from old battery first and connect to new battery last.
- **CONNECTING A BATTERY CHARGER** — remove battery from welder by disconnecting negative cable first, then positive cable and battery clamp. When reinstalling, connect negative cable last. Keep well ventilated.
- **USING A BOOSTER** — connect positive lead to battery first then connect negative lead to negative battery lead at engine foot.

⚠ CAUTION



BATTERY ACID can burn eyes and skin.

- Wear gloves and eye protection and be careful when working near battery.
- Follow instructions printed on battery.

IMPORTANT

To prevent ELECTRICAL DAMAGE WHEN:

- a) Installing new battery.
- b) Using a booster.

Use correct polarity — NEGATIVE GROUND.

The MAVERICK 260X is shipped with the negative battery cable disconnected. Before you operate the machine, make sure the Run / Stop switch is in the STOP position and attach the disconnected cable securely to the negative (-) battery terminal.

Remove the insulating cap from the negative battery terminal. Replace and tighten negative battery cable terminal.

Note: This machine is furnished with a wet charged battery; if unused for several months, the battery may require a booster charge. Be sure to use the correct polarity when charging the battery.

MUFFLER OUTLET PIPE

Remove the plastic plug covering the muffler outlet tube. Using the clamp provided secure the outlet pipe to the outlet tube with the pipe positioned such that it will direct the exhaust in the desired position.

SPARK ARRESTOR

Some federal, state or local laws may require that petrol or diesel engines be equipped with exhaust spark arrestors when they are operated in certain locations where unarrested sparks may present a fire hazard. When required by local regulations, a suitable spark arrestor, must be installed and properly maintained.

CAUTION

An incorrect arrestor may lead to damage to the engine or adversely affect performance.

CASE FRONT CONTROLS

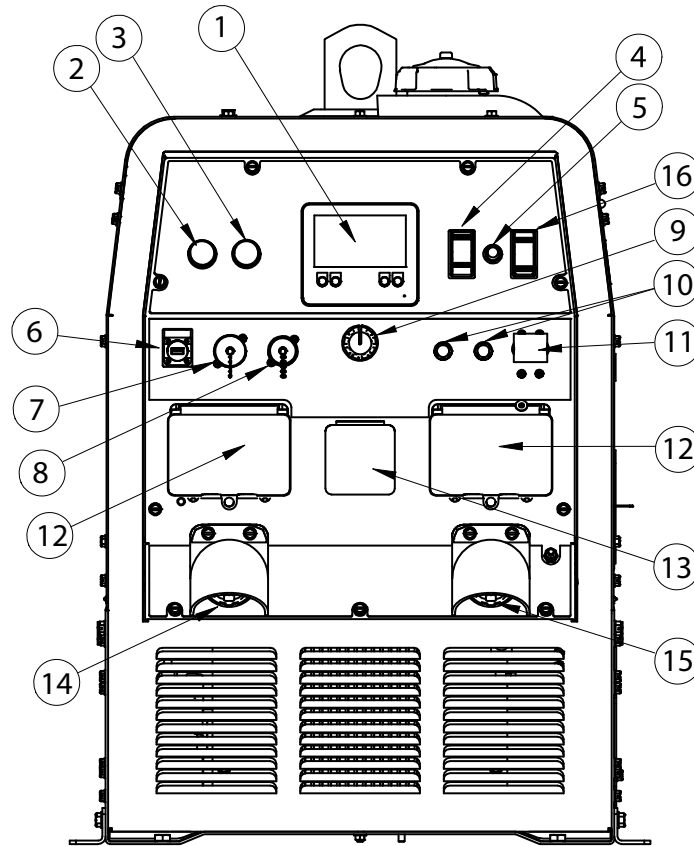

Figure 3 : CASE FRONT CONTROLS

1. **LCD SCREEN, IP67 RATED** - The LCD screen display information about welding mode, output voltage or current, engine status and machine settings. It allows the operator to select welding mode and read output voltage or current when presetting using the output control knob. During welding, the screen displays the actual output voltage (VOLTS) and current (AMPS). A memory feature holds the screens on for 5 seconds after welding stopped. This allow the operator to read the actual current and voltage just prior to when welding was ceased. In engine status section, information about engine hours, filters condition, engine oil and other service items are displayed.
2. **GLOW PLUG PUSH BUTTON** - When pushed activates the Glow Plugs. Glow Plug should not be activated for more than 20 seconds continuously.
3. **START PUSH BUTTON** - Energizes the starter motor to crank the engine.
4. **RUN / STOP SWITCH** - RUN position energizes the engine priopr to starting STOP position stops the engine. The oil pressure interlock switch prevents the battery drain if the switch is left in the RUN position and the engine is not operating.
5. **BATTERY CIRCUIT BREAKER** - For protection of battery charging circuit.
6. **USB PORT** - allows the customer to update their welder by uploading new software via USB drive through front panel.
7. **6-PIN REMOTE CONTROL CONNECTOR** -For attaching optional remote control equipment. Includes auto sensing remote control circuit.
8. **7-PIN SPOOL GUN CONNECTION** For attaching optional spool gun equipment. Includes contactor closure circuit and auto sensing remote control circuit.

9. **OUTPUT CONTROL** - The output knob is used to preset the output voltage or current as displayed on the LCD screen for the six welding modes. When in the ARC GOUGING or CV - WIRE modes and when a remote control is connected to the 6 - Pin or 14 Pin connector, the auto sensing circuit automatically switches the OUTPUT CONTROL from control at the welder to the remote control. The knob is also used for settings and setup manipulation.
10. **20 AMP CIRCUIT BREAKERS (2)** - Protects the two single phase - GFCI 120V receptacles.
11. **50 AMP CIRCUIT BREAKER** - Protects the 240V, single phase receptacle.
12. **GFCI-120V DUPLEX RECEPTACLES (2)**
13. **240VAC SINGLE PHASE RECEPTACLE**
14. **POSITIVE WELD TERMINAL** - Provides a connection point for the electrode cable.
15. **NEGATIVE WELD TERMINAL** - Provides a connection point for the work cable.
16. **IDLE SWITCH** - Place switch in the up position to select High Idle . Place the switch in the down position for Auto idle.

WELDING TERMINALS

From the main screen select MIG / FCAW / TIG welding. Press knob to select screen that shows Weld Output Override ([Figure 4](#) : on page A-13).

Press knob to select either OFF - output controlled by welding gun switch or ON - output always ON (electrode always hot).

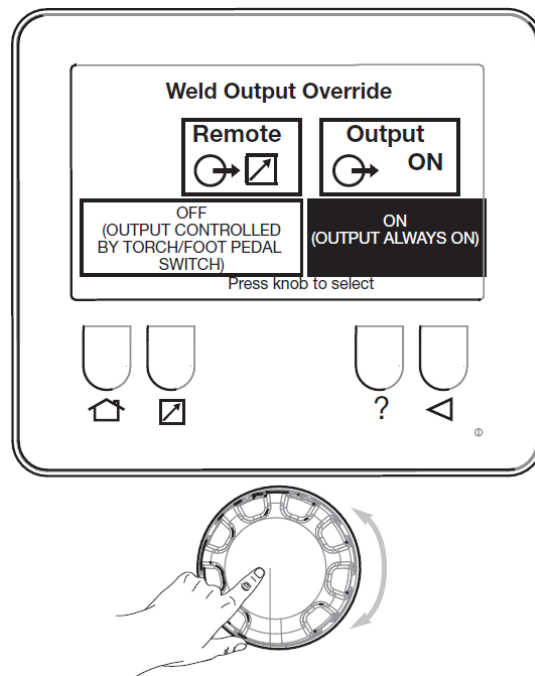

Figure 4 :

WELDING OUTPUT CABLES

With the engine off, connect the electrode and work cables to the terminals provided. These connections should be checked periodically and tightened if necessary.

Listed in [Table 1 :TOTAL COMBINED LENGTH OF ELECTRODE AND WORK CABLES](#) on page A-14 are copper cable sizes recommended for the rated current and duty cycle. Lengths stipulated are the distance from the

INSTALLATION

welder to work and back to the welder again. Cable sizes are increased for greater lengths primarily for the purpose of minimizing cable voltage drop.

Table 1 :TOTAL COMBINED LENGTH OF ELECTRODE AND WORK CABLES

| Cable Length | Cable Size for 300 AMPS 60% Duty Cycle |
|--------------------------------|--|
| Lengths up to 100 ft. (30m) | 1/0 AWG |
| 100 ft. (30m) to 150 ft. (61m) | 1/0 AWG |
| 150 ft. (46m) to 200 ft. (61m) | 2/0 AWG |

MACHINE GROUNDING

This portable engine driven welder creates its own power. It is not necessary to connect its frame to an earth ground, unless the machine is connected to premises wiring (home, shop, etc.).

 **WARNING**



To prevent dangerous electric shock, other equipment to which this engine driven welder supplies power must:

- Be grounded to the frame of the welder using a grounded type plug or be double insulated.
- Do not ground the machine to a pipe that carries explosive or combustible material.

When this welder is mounted on a truck or trailer, its frame must be securely connected to the metal frame of the vehicle. When this engine driven welder is connected to premises wiring in a home or shop, its frame must be connected to the system earth ground. See further connection instructions in the section entitled "Standby Power Connections" as well as the article on grounding in the latest National Electrical Code and the local codes.

In general, if the machine is to be grounded, it should be connected with a #8 or larger copper wire to a solid earth ground such as a metal ground stake going into the ground for at least 10 Feet or to the metal framework of a building which has been effectively grounded.

The National Electric Code lists a number of alternate means of grounding electrical equipment. A machine grounding stud marked with the symbol to the right is provided on the front of the welder.



REMOTE CONTROL

The MAVERICK 260X is equipped with a 6-pin connector. The 6-pin connector is for connecting the K857 or K857-1 Remote Control or for TIG welding, the K870 foot Amptrol or the K963-3 Hand Amptrol. When in CC-STICK, ARC GOUGING, TIG or CV- WIRE modes and when a remote control is connected to the 6-pin Connector, the auto-sensing circuit automatically switches the OUTPUT control from control at the welder to remote control.

Note: Wire feeders should NOT be used while in TIG mode.

In each case, once connected control maybe optionally changed back to the control panel using the display remote button. The maximum and minimum current range can be setup / modified in display.

STANDBY POWER CONNECTIONS

The MAVERICK 260X is suitable for temporary, standby or emergency power using the engine manufacturer's recommended maintenance schedule.

The MAVERICK 260X can be permanently installed as a standby power unit for 240 VAC, single phase, 38 AMP service.

Connections must be made by a licensed electrician who can determine how the power can be adapted to the particular installation and comply with all applicable electrical codes.

Take necessary steps to assure load is limited to the capacity of the MAVERICK 260X.

CABLE INDUCTANCE AND ITS EFFECTS ON WELDING

Excessive cable inductance will cause the welding performance to degrade. There are several factors that contribute to the overall inductance of the cabling system including cable size, length, and number of loops. To reduce cable inductance do not loop welding cables see the figure on the left, especially consistently in one direction. If there are loops separate them as much as possible and make the loop as large as possible. A straight or zig-zag pattern between the machine and work is recommended see [Figure 5](#): on page A-15 .

If a spooling mechanism is used to store the welding cables, unspool the cables. Avoid leaving more than 30 feet of cable on each storage spool. For best performance completely unspool the welding cables.

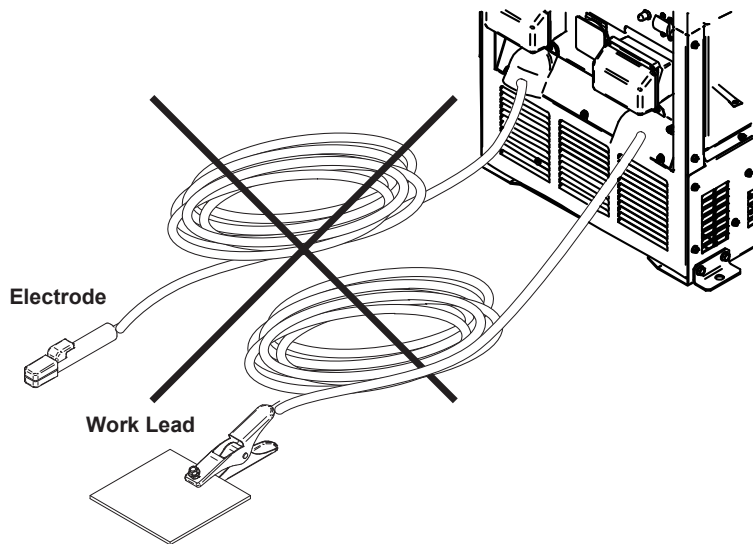
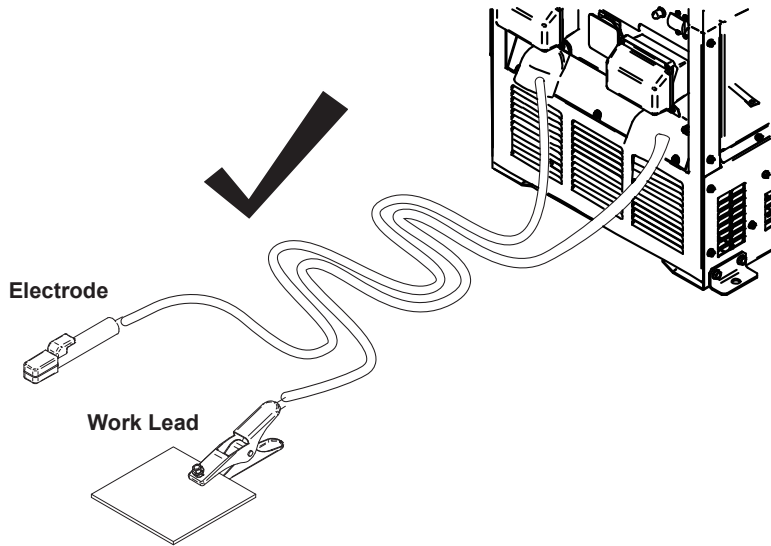

Figure 5 :

INSTALLATION



WIRE WELDING SET-UP

Electrode Positive (+) shown

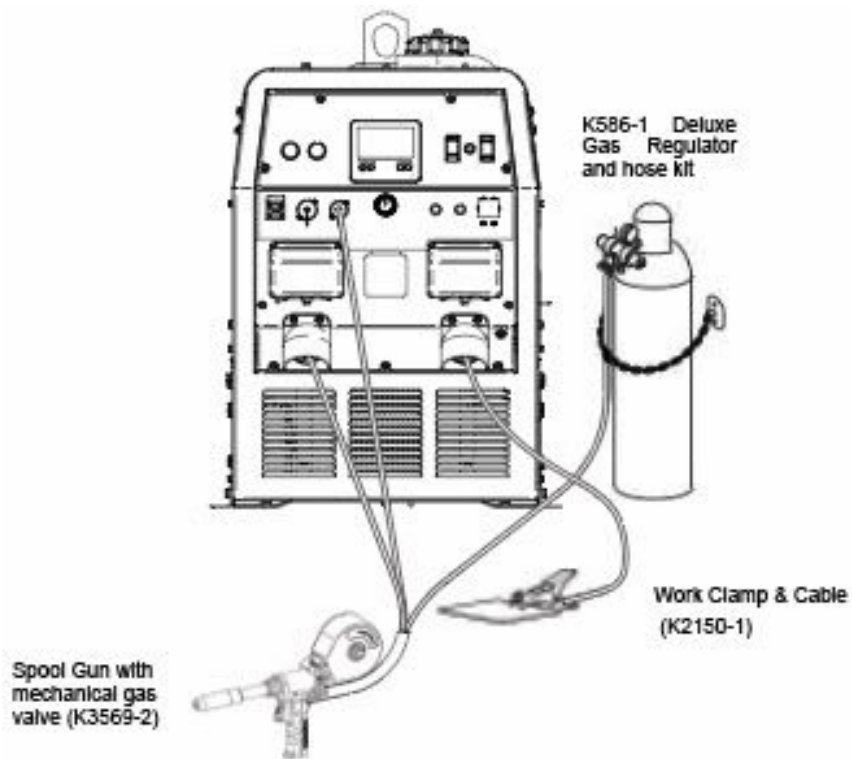

Figure 6 :

In the spool gun mode, the weld output is controlled by the trigger of the spool gun. The knob on the Dual Maverick display sets voltage and the spool gun knob sets wire feed speed. Rotating the knob on the spool gun adjusts the work point (wire feed speed). Spool gun modes have the option of being “synergic” (when

the wire feed speed is changed, the voltage is automatically modified up or down to maintain a similar arc length).

Spool guns are also compatible with other wire feed modes, such as MIG, FCAW and ROOT WAVE. When in a wire feed mode and the spool gun is connected, the wire feed speed will adjust to match the potentiometer located on the spool gun, as long as the wire feed speed is above 70. The wire feed speed may be adjusted for a separate wire feeder while the spool gun is connected. If the spool gun's potentiometer is changed to 0 (the spool gun pot being adjusted all the way to CCW) the user may manually adjust the wire feed speed.

If desired, a remote can be plugged into the 6 pin connector for setting the voltage away from the MAVERICK 260X.

The best spool gun operation is obtained with the Magnum Pro LX GT spool gun with mechanical gas flow trigger and Magnum Pro consumables. The standard Magnum PRO 250 LX gun is also supported but requires an external gas control. The Magnum SG spool gun and Magnum PRO 100 SG spool gun are not supported.

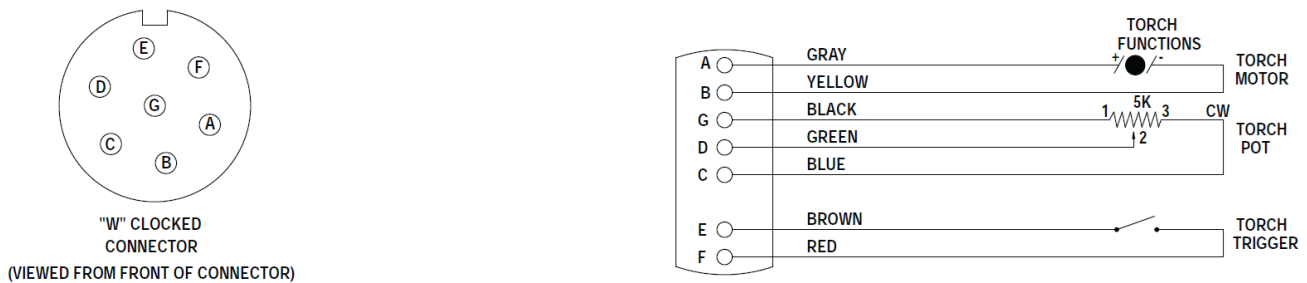



Figure 7 :

AUXILIARY POWER RECEPTACLES

For heavy loads switch the control switch to the "HIGH IDLE" mode and set weld output at max.

The auxiliary power capacity is 2400 Watts continuous of 120 VAC 60 Hz single phase power for each of the 2 receptacles and 9,000 Watts continuous of 240VAC 60 Hz single phase power.

AUXILIARY POWER

|  CAUTION | |
|--|--|
|  | <p>An electric shock can result in serious injury or death.</p> <ul style="list-style-type: none"> • Always perform the GFCI test before using the generator. If the GFCI system fails the test, the machine must be repaired by an authorized service center. • Due to the risk of power interruption, do not power life support equipment from this machine. • Unplug accessories and tools before attempting service. • Close the front service doors protecting the receptacles when operating the machine. • Do not test or reset the GFCI while at idle speed. • If the LED blinks, stop using the GFCI receptacle and have it replaced by an authorized service center. • Long extension cords or cords with poor insulation may allow enough leakage current to trip the GFCI. • If LED does not light up while machine is in HIGH idle, and resetting does not work, stop using the GFCI receptacle and have it replaced by an authorized service center. |

When set to high idle, the output frequency is controlled to 56 to 63 Hz under steady state conditions. If the machine is set to AUTO, the output frequency may drop to 42 Hz with a lower voltage. Verify equipment connected to the MAVERICK 260X is compatible with the frequency and voltage.

For equipment affected by momentary voltage fluctuations, install a plug-in surge suppressor on the receptacles feeding the equipment.

The Lincoln Electric Company is not responsible for any damage to electrical components improperly connected to this product.

CONNECTION OF ACROSS THE ARC WIRE FEEDERS TO THE MAVERICK 260X

These connections instructions apply to both the LN-25X Pro, Activ8X and CrossLinc models.

- Shut the welder off.
- For electrode Positive, connect the electrode cable to the "+" terminal of the welder and work cable to the "-" terminal of the welder. For electrode Negative, connect the electrode cable to the "-" terminal of the welder and work cable to the "+" terminal of the welder.
- Attach the single lead from the front of the feeder to work using the spring clip at the end of the lead. This is a control lead to supply current to the wire feeder motor; it does not carry welding current (See [Figure 8 : CROSSLINC WIRE FEEDER SETUP EXAMPLE](#) on page A-19).
- For the CrossLinc Remote, connect the remote in series with the wire feeder and/or electrode and the weld cable of the desired polarity (See [Figure 9 : CROSSLINC REMOTE SETUP EXAMPLE](#) on page A-19).

CROSSLINC TECHNOLOGY - This machine features CrossLinc technology, which allows for remote control of the welding output via the weld cables rather than a control cable. As result, the control cable is no longer needed when connected to a CrossLinc compatible wire feeder or remote control.

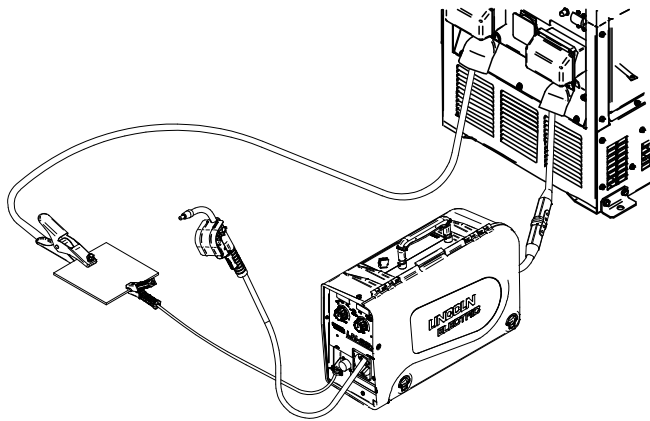

| DESCRIPTION | PRODUCT NUMBER | QTY |
|--|----------------|-----|
| LN-25X Wire Feeder | K4267-2 | 1 |
| K126 [®] PRO Innershield [®] 350A FCAW-S Welding Gun | K126-12 | 1 |
| Electrode Cable - 2/0, 50 ft. (15.3 m), Black | K2485-2 | 2 |
| Electrode Cable - 2/0, 10 ft. (3.1 m), Black | K2483-2 | 1 |
| Work Clamp | K910-1 | 1 |
| Cable Connectors - TWECO to Lug Adaptor | K2487-1 | 2 |

Figure 8 : CROSSLINC WIRE FEEDER SETUP EXAMPLE

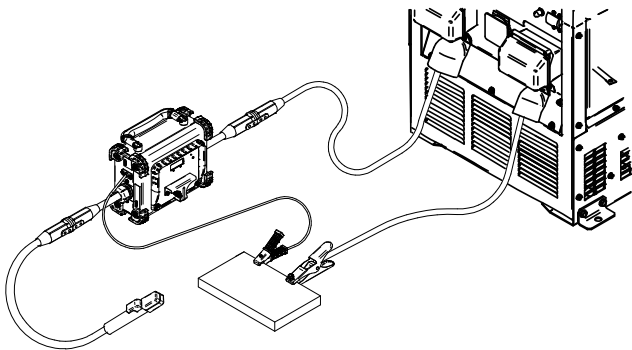

| DESCRIPTION | PRODUCT NUMBER | QTY |
|--|----------------|-----|
| CrossLinc [®] Remote | K434 5-1 | 1 |
| EH-305D Electrode Holder | K909-7 | 1 |
| Electrode Cable - 2/0, 50 ft. (15.3 m), Black | K2485-2 | 2 |
| Electrode Cable - 2/0, 10 ft. (3.1 m), Black | K2483-2 | 1 |
| Work Clamp | K910-1 | 1 |
| Cable Connectors - TWECO to Lug Adaptor | K2487-1 | 2 |

Figure 9 : CROSSLINC REMOTE SETUP EXAMPLE

ELECTRICAL DEVICE USE WITH THIS PRODUCT

| | |
|---|---|
| ⚠ CAUTION | |
|  | Certain electrical devices cannot be powered by this product. See Table 2 :ELECTRICAL DEVICE USE WITH THIS PRODUCT on page A-20 . |

Table 2 :ELECTRICAL DEVICE USE WITH THIS PRODUCT

| Type | Common Electrical Devices | Possible Concerns |
|------------------------|--|---|
| Resistive | Heaters, toasters, incandescent light bulbs, electric range, hot pan, skillet, coffee maker. | NONE |
| Capacitive | TV sets, radios, microwaves, appliances with electrical control. | Voltage spikes or high voltage regulation can cause the capacitive elements to fail. Surge protection, transient protection, and additional loading is recommended for 100% fail-safe operation. DO NOT RUN THESE DEVICES WITHOUT ADDITIONAL RESISTIVE TYPE LOADS. |
| Inductive | Single-phase induction motors, drills, well pumps, grinders, small refrigerators, weed and hedge trimmers. | These devices require large current inrush for starting. Some synchronous motors may be frequency sensitive to attain maximum output torque, but they SHOULD BE SAFE from any frequency induced failures. |
| Capacitive / Inductive | Computers, high resolution TV sets, complicated electrical equipment. | An inductive type line conditioner along with transient and surge protection is required, and liabilities still exist. DO NOT USE THESE DEVICES WITH THIS PRODUCT. |

The Lincoln Electric Company is not responsible for any damage to electrical components improperly connected to this product.

OPERATION

SAFETY PRECAUTIONS

Read and understand this entire section before operating your MAVERICK 260X.

WARNING



- Do not attempt to use this equipment until you have thoroughly read the engine manufacturer's manual supplied with your welder. It includes important safety precautions, detailed engine starting, operating and maintenance instructions, and parts lists.

WARNING



ELECTRIC SHOCK can kill.

- Do not touch electrically live parts or electrode with skin or wet clothing.
- Insulate yourself from work and ground.
- Always wear dry insulating gloves.

WARNING



ENGINE EXHAUST can kill.



- Use in open, well ventilated areas or vent exhaust outside.
- Do not stack anything near the engine.

WARNING



MOVING PARTS can injure.

- Do not operate with doors open or guards off.
- Stop engine before servicing.
- Keep away from moving parts.

|  WARNING | |
|--|--|
|  | <ul style="list-style-type: none"> • Only qualified personnel should operate this equipment. • Always operate the welder with the door closed and the side panels in place as these provide maximum protection from moving parts and insure proper cooling air flow. |

GENERAL DESCRIPTION

The MAVERICK 260X is a diesel engine-driven welding power source. The machine uses an alternator / generator for DC multipurpose welding, for 120 VAC single phase, 240 VAC single phase. The DC welding control system uses state of the art Chopper Technology for superior welding performance.

The MAVERICK 260X is fitted with a selectable VRD (Voltage Reduction Device). The VRD operates in the Stick, TIG, PIPE and GOUGE modes reducing the OCV to <13 volts, increasing operator safety when welding is performed in environments with increased hazard of electric shock such as wet areas and hot, humid sweaty conditions.

FOR AUXILIARY POWER



Start the engine and set the IDLER control switch to the desired operating mode. Full power is available regardless of the welding control settings providing no welding current is being drawn.

ENGINE OPERATION CHECK

Before Starting the Engine:

- Be sure the machine is on a level surface.
 - Open side engine door and remove the engine oil dipstick and wipe it with a clean cloth. Reinsert the dipstick and check the level on the dipstick.
 - Add oil (if necessary) to bring the level up to the full mark. Do not overfill. Close engine door.
- 
- DO NOT operate with oil below low mark on dipstick.
 - DO NOT fill above full mark on dipstick.
 - Check radiator for proper coolant level. (Fill if necessary).
 - See Engine Owner's Manual for specific oil and coolant recommendations.

ADD FUEL

|  WARNING | |
|--|---|
|  | <p>DIESEL FUEL can cause fire.</p> <ul style="list-style-type: none"> • Stop engine while fueling. • Do not smoke when fueling. • Keep sparks and flame away from tank. • Do not leave unattended while fueling. • Wipe up spilled fuel and allow fumes to clear before starting engine. • Do not overfill tank, fuel expansion may cause overflow. |

⚠ WARNING

DIESEL FUEL ONLY - Low sulfur fuel or ultra low sulphur fuel in U.S.A. and Canada.

- Remove the fuel tank cap.
- Fill the tank. **DO NOT FILL THE TANK TO THE POINT OF OVERFLOW.**
- Replace the fuel cap and tighten securely.
- See Engine Owner's Manual for specific fuel recommendations.

FUEL PUMP WITH PRIMER LEVER

- Hard to Start
- Run rough
- Misfire
- Fuel knock

For faster air purge, a small amount of air can be vented from the system by pumping the fuel primer lever (see [Figure 10 : Engine Service Side View](#) on page B-3).

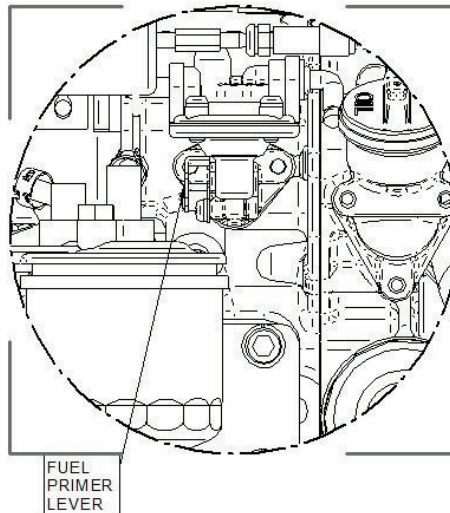

Figure 10 : Engine Service Side View

RECOMMENDED APPLICATIONS

The MAVERICK 260X provides excellent constant current DC welding output for stick (SMAW) and TIG welding. The MAVERICK 260X also provides excellent constant voltage DC welding output for MIG (GMAW), Innershield (FCAW), Outershield (FCAW-G) and Metal Core welding. In addition the MAVERICK 260X can be used for Arc Gouging with carbons up to 3/8"(10mm) in diameter.

The MAVERICK 260X is not recommended for pipe thawing.

GENERATOR

The MAVERICK 260X provides smooth 120 VAC single phase and 240 VAC single phase, 60Hz output for auxiliary power and emergency standby power.

AUTO-START INSTRUCTION

1. To make Auto Start active, press home button for the main menu. Rotate knob to select "Setup" icon and press knob.
2. Auto-Start On/Off: Determines On/Off states for Auto-start feature.
 - a. Rotate knob to select "Auto-Start On/Off" and press knob to confirm.
 - b. Rotate knob to select "On" or "Off" and press knob to confirm.
3. Auto-Start No Load Period: Determines when no load is on, how long the welder will be on before auto shutdown. This period will be reset to the setting value when load appears.
 - a. Rotate knob to select "Auto-Start No Load Period" and press knob to confirm.
 - b. Rotate knob to change the period from 15 min to 120 min and press knob to confirm.
4. Tap-Start Active Period: Determines how long tap start will be active.
 - a. Rotate knob to select "Tap-Start Active Period" and press knob to confirm.
 - b. Rotate knob to change the period from 15 min to 120 min and press knob to confirm.
5. Press home button to go to the main menu. Select welding mode. Confirm Auto Start settings on the display.
6. When Auto-Start feature is turned "ON" and a remote is plugged in the engine can be remotely turned off by completing the following pattern on the remote knob:
 - a. Remote Knob to Min.
 - b. Remote knob to Max.
 - c. Remote Knob to Middle.
 - d. Remote knob to Max.
 - e. Remote knob to Min.

Note: Each step should be completed within 3 seconds.

7. Auto start does not work when small loads such as across the arc wire feeders are connected. In this case turn Auto Start off.
8. To restart engine, firmly tap and hold electrode to work for 0.1 to 1 sec. Ensure there is direct contact between metal part of the electrode and work.
9. Pull electrode away from work and wait a few seconds for engine to come up to speed.

Note: Small loads across the output terminals such as an across the arc wire feeder may cause the auto start count to restart without shutting down the engine. Remove any such small loads. Or turn Auto start off.

BREAK-IN PERIOD

Lincoln Electric selects high quality, heavy-duty industrial engines for the portable welding machines we offer. While it is normal to see a small amount of crankcase oil consumption during initial operation, excessive oil use, wetstacking (oil or tar like substance at the exhaust port), or excessive smoke is not normal.

Larger machines with a capacity of 350 amperes and higher, which are operated at low or no-load conditions for extended periods of time are especially susceptible to the conditions described above. To accomplish successful engine break-in, most diesel-powered equipment needs only to be run at a reasonably heavy load within the rating of the welder for some period of time during the engine's early life. However, if the welder is subjected to extensive light loading, occasional moderate to heavy loading of the engine may sometimes be necessary. Caution must be observed in correctly loading a diesel/generator unit.

1. Connect the welder output studs to a suitable resistive load bank. Note that any attempt to short the output studs by connecting the welding leads together, direct shorting of the output studs, or connecting the output leads to a length of steel will result in catastrophic damage to the generator and voids the warranty.
2. Set the welder controls for an output current and voltage within the welder rating and duty cycle. Note that any attempt to exceed the welder rating or duty cycle for any period of time will result in catastrophic damage to the generator and voids the warranty.
3. Periodically shut off the engine and check the crankcase oil level.

CAUTION



During break-in, subject the Welder to moderate loads. Avoid long periods running at idle. Before stopping the engine, remove all loads and allow the engine to cool several minutes.

ENGINE OPERATION

Starting The Engine

1. Open the engine service compartment door and check that the fuel shutoff valve on the fuel filter separator located on the lift bale is in the open position.
2. Check for proper oil level and coolant level. Close engine service compartment door.
3. Remove heavy auxiliary loads from the AC power receptacles.
4. Set the High/Auto idle switch to "AUTO IDLE".
5. For cold weather starting, press Glow Plug Button and hold 5 to 10 seconds.
6. Press START button until the engine starts or for up to 10 seconds.
7. Release the engine START button when the engine starts.
8. Allow the engine to warm up at low idle speed for several minutes before applying a load and/or switching to high idle. Allow a longer warm up time in cold weather.

Cold Weather Starting

With a fully charged battery and the proper weight oil, the engine should start satisfactorily even down to about -5°C (23°F) below this it may be desirable to use the included block heater.

Note: Extreme cold weather starting may require longer glow plug operations.

OPERATION

Stopping The Engine

Switch the RUN/STOP switch to "STOP". This turns off the voltage supplied to the shutdown solenoid. A backup shutdown can be accomplished by shutting off the fuel valve located on the fuel pre-filter located on the lift bale.

TYPICAL FUEL CONSUMPTION

Refer to [Table 3](#) : on page B-6 for typical fuel consumption of the MAVERICK 260X Engine for various operating settings.

Table 3 :

| TYPICAL MAVERICK 260X FUEL CONSUMPTION | | |
|--|--------------------------------|--|
| Load | KUBOTA T4F gal./hr (liters/hr) | Operating Time for 12 gallons (45.4 L) (Hours) |
| Low Idle No Load | 0.212 (0.80) | 56.50 |
| 2650 RPM | | |
| High Idle No Load | 0.383 (1.45) | 31.32 |
| 3825 RPM | | |
| 100A @ 24V | 0.479 (1.812) | 25.06 |
| 130A @ 25.2V | 0.533 (2.016) | 22.53 |
| 200A @ 28V | 0.676 (2.559) | 17.75 |
| 260A @ 30.4V | 0.895 (2.10) | 13.41 |
| 300A @ 26.35V | 0.879 (3.328) | 13.65 |
| 9KW AUXILIARY | 0.837 (3.17) | 14.337 |
| 3600 RPM | | |

Note: The density of diesel fuel used was accurately measured for the above information to be 0.8732 kg/L.

WELDER OPERATION

Duty Cycle

Duty Cycle is the percentage of time the load is being applied in a 10 minute period. For example a 60% duty cycle, represents 6 minutes of load and 4 minutes of no load in a 10 minute period.

Electrode Information

For any electrode the procedures should be kept within the rating of the machine. For information on electrodes and their proper application see (www.lincolnelectric.com) or the appropriate Lincoln publication.

The MAVERICK 260X can be used with a broad range of DC stick electrodes. The MODE switch provides two stick welding settings as follows:

Constant Current (CC-STICK) Welding

Stick "Mode" is designed for horizontal and vertical-up welding with all types of electrodes, especially low hydrogen.

The ARC Force setting on the mode screen controls the short circuit current (arc-force) during stick welding to adjust for a soft or crisp arc. Increasing the number from -10(soft) to +10(crisp) increases the short circuit current and prevents sticking of the electrode to the plate while welding. This can also increase spatter. It is

recommended that the ARC CONTROL be set to the minimum number without electrode sticking. Start with the dial set at 0 (OFF).

Note: Due to the low OCV with the VRD on, a very slight delay during striking of the electrodes may occur. Due to the requirement of the resistance in the circuit to be low for a VRD to operate, a good metal-to-metal contact must be made between the metal core of the electrode and the job. A poor connection anywhere in the welding output circuit may limit the operation of the VRD. This includes a good connection of the work clamp to the job. The work clamp should be connected as close as practical to where the welding will be performed.

For Re-Striking Electrodes

Some electrodes form a cone at the end of the electrode after the welding arc has been broken, particularly iron powder and low hydrogen electrodes. This cone will need to be broken off in order to have the metal core of the electrode make contact.

E6010 - To begin welding with VRD active.

E7018, E7024 - Tap, slide and lift in one motion.

Once the arc is started, normal welding technique for the application is then used.

For other electrodes the above techniques should be tried first and varied as needed to suit operator preference. The goal for successful starting is good metal to metal contact.

DOWNHILL PIPE Welding

This slope controlled mode is intended for "out-of-position" and "down hill" pipe welding where the operator would like to control the current level by changing the arc length.

The ARC FORCE setting sets the short circuit current (arc-force) during stick welding to adjust for a soft or more forceful digging arc (crisp). Increasing the number from -10(soft) to +10(crisp) increases the short circuit current which results in a more forceful digging arc.

Typically a forceful digging arc is preferred for root and hot passes. A softer arc is preferred for fill and cap passes where weld puddle control and deposition ("stacking" of iron) are key to fast travel speeds. This can also increase spatter.

It is recommended that the ARC FORCE be set to the minimum number without electrode sticking. Start with the setting at 0.

Note: With the VRD set to the "ON" position (See [Figure 2](#): on page A-6 for location) there is no output in the downhill pipe mode.

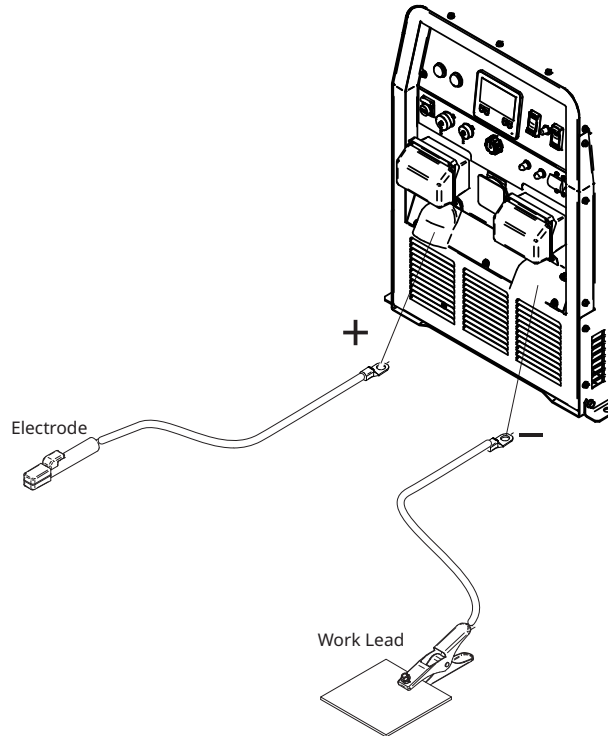

TIG Welding

The TOUCH START TIG is for DC TIG (Tungsten Inert Gas) welding. To initiate a weld, the selector knob is used to set to the desired current and the tungsten is touched to the work. During the time the tungsten is touching the work there is very little voltage or current and, in general, no tungsten contamination. Then, the tungsten is gently lifted off the work in a rocking motion, which establishes the arc.

When in the touch start TIG mode and when a Amptrol is connected to the 6-Pin connector the selector knob is used to set the maximum current range of the current control of the Amptrol.

The ARC FORCE is not active in the TIG mode. To STOP a weld, simply pull the TIG torch away from the work.

When the arc voltage reaches approximately 30 Volts the arc will go out and the machine will reset the current to the Touch Start level.

To reinitiate the arc, retouch the tungsten to the work and lift. Alternatively, the weld can be stopped by releasing the Amptrol or arc start switch.

The MAVERICK 260X can be used in a wide variety of DC TIG welding applications. In general the 'Touch Start' feature allows contamination free starting without the use of a Hi frequency unit.

If desired, the K930-2 TIG Module can be used with the MAVERICK 260X. The settings are for reference.

MAVERICK 260X settings when using the K930-2 TIG Module with an Amptrol or Arc Start Switch:

- Set the MODE to the TOUCH START TIG setting.
- Set the "IDLER" Switch to the "AUTO/IDLE/RUN" position.
- Set the "Weld Output Override" to the "REMOTELY CONTROLLED" position.

This will keep the "Solid State" contactor open and provide a "cold" electrode until the Amptrol or Arc Start Switch is pressed.

When using the TIG Module, the selector knob on the MAVERICK 260X is used to set the maximum range of the CURRENT CONTROL on the TIG Module or an Ampctrl if connected to the TIG Module.

Note: The TIG process is to receive a low voltage welding process. There is no difference in operation with the VRD "ON" or "OFF" for this mode.

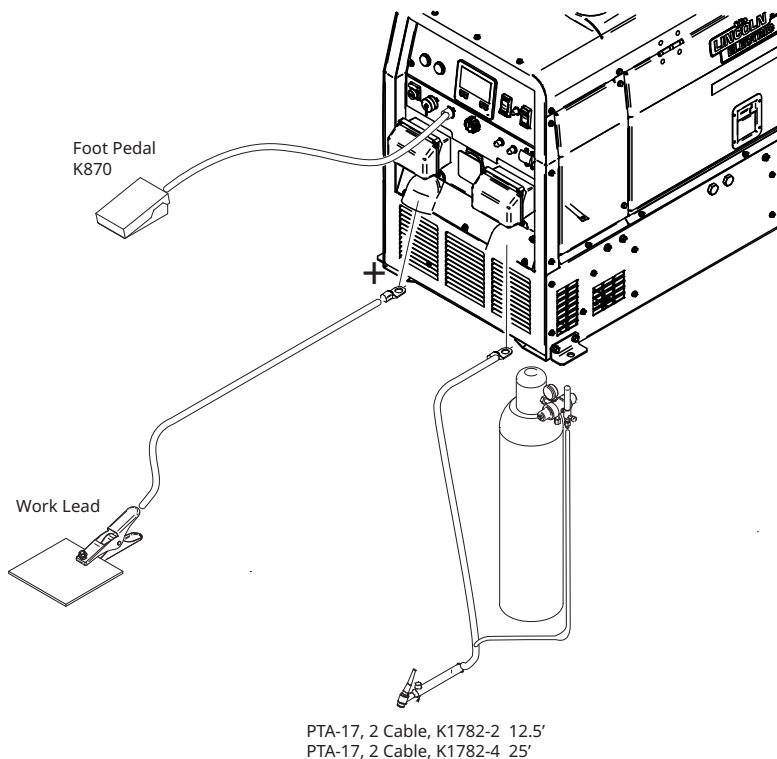

| TYPICAL CURRENT RANGES ⁽¹⁾ FOR TUNGSTEN ELECTRODES ⁽²⁾ | | | | | |
|--|---------------------------|---------------------------|---|-----------------|---|
| Tungsten Electrode Diameter in. (mm) | DCEN (-) | DCEP (+) | Approximate Argon Gas Flow Rate C.F.H. (l /min.) | | TIG TORCH Nozzle Size ^{(4), (5)} |
| | 1%, 2% Thoriated Tungsten | 1%, 2% Thoriated Tungsten | Aluminum | Stainless Steel | |
| .010 (.25) | 2-15 | ⁽³⁾ | 3-8 (2-4) | 3-8 (2-4) | #4, #5, #6 |
| 0.020 (.50) | 5-20 | ⁽³⁾ | 5-10 (3-5) | 5-10 (3-5) | |
| 0.040 (1.0) | 15-80 | ⁽³⁾ | 5-10 (3-5) | 5-10 (3-5) | |
| 1/16 (1.6) | 70-150 | 10-20 | 5-10 (3-5) | 9-13 (4-6) | #5, #6 |
| 3/32 (2.4) | 150-250 | 15-30 | 13-17 (6-8) | 11-15 (5-7) | #6, #7, #8 |
| 1/8 (3.2) | 250-400 | 25-40 | 15-23 (7-11) | 11-15 (5-7) | |
| 5/32 (4.0) | 400-500 | 40-55 | 21-25 (10-12) | 13-17 (6-8) | #8, #10 |

Note: (1) When used with argon gas. The current ranges shown must be reduced when using argon/helium or pure helium shielding gases.

Note: (2) Tungsten electrodes are classified as follows by the American Welding Society (AWS):

- Pure EWP
- 1% Thoriated EWTh-1
- 2% Thoriated EWTh-2

Though not yet recognized by the AWS, Ceriated Tungsten is now widely accepted as a substitute for 2% Thoriated Tungsten in AC and DC applications.

Note: (3) DCEP is not commonly used in these sizes.

OPERATION

Note: (4) TIG torch nozzle "sizes" are in multiples of 1/16ths of an inch:

| | |
|----------------|-----------|
| # 4 = 1/4 in. | (6 mm) |
| # 5 = 5/16 in | (8 mm) |
| # 6 = 3/8 in. | (10 mm) |
| # 7 = 7/16 in. | (11 mm) |
| # 8 = 1/2 in. | (12.5 mm) |
| #10 = 5/8 in. | (16 mm) |

Note: (5) TIG torch nozzles are typically made from alumina ceramic. Special applications may require lava nozzles, which are less prone to breakage, but cannot withstand high temperatures and high duty cycles.

Wire Welding-CV

Connect a wire feeder to the MAVERICK 260X according to the instructions in INSTALLATION INSTRUCTIONS Section.

The MAVERICK 260X in the CV-WIRE mode, permits it to be used with a broad range of flux cored wire (Innershield and Outershield) electrodes and solid wires for MIG welding (gas metal arc welding). Welding can be finely tuned using the PINCH from -10 (soft) to +10 (crisp) changes the arc from soft and washed-in to crisp and narrow. It acts as an inductance/pinch control. The proper setting depends on the procedure and operator preference. Start with the setting at 0 (OFF).

If the engine bogs while wire welding check that the power required for the process does not exceed the rated power of the machine. For unusually high wire feed speeds and voltage combinations it may be necessary to set the idler switch to high idle.

Arc Gouging

MAVERICK 260X can be used for Arc Gouging with carbons up to 3/8" (10mm) in diameter.

Use the selector knob to adjust output current to the desired level for the gouging electrode being used.

The ARC FORCE is not active in the ARC GOUGING Mode. The ARC FORCE is automatically set to maximum when the ARC GOUGING mode is selected which provides the best ARC GOUGING performance.

PARALLELING

When paralleling machines in order to combine their outputs, all units must be operated in the CC-STICK mode only at the same output settings. Use the selector knob to choose stick mode from the home screen. Set each machine to half the desired current. Operation in other modes may produce erratic outputs, and large output imbalances between the units.

AUXILIARY POWER OPERATION

Start the engine and set the IDLER control switch to the desired operating mode. Full power is available regardless of the welding control settings, if no welding current is being drawn.

For heavy loads set to HIGH IDLE and maximum weld output for maximum starting power.

SIMULTANEOUS WELDING AND AUXILIARY POWER LOADS

It must be noted that the specified auxiliary power ratings are with no welding load.

Simultaneous welding and power loads are specified in [Table 4 :MAVERICK 260X SIMULTANEOUS WELDING AND POWER LOADS](#) on page B-11 .

Table 4 :MAVERICK 260X SIMULTANEOUS WELDING AND POWER LOADS

| Simultaneous Welding and Power Loads (120/240V AUX) | | | |
|--|------------|--------------------------|--------------------------|
| Single Current | Aux Power | Single Phase Amps (240V) | |
| 0 | 9000 | 37.5 | |
| 100 | 6214 | 25.9 | |
| 200 | 2500 | 10.4 | |
| 250 | 295 | 1.2 | |
| 260 | 0 | 0.0 | |
| Simultaneous Welding and Power Loads (120 AUX) | | | |
| Single Current | Weld Power | Aux Power | Single Phase Amps (120V) |
| 141 | 3618 | 2400 + 2400 | 20 + 20 |
| 173 | 4652 | 2400 + 1200 | 20 + 10 |
| 202 | 5686 | 2400 + 0 | 20 + 0 |
| 230 | 6720 | 1200 + 0 | 10 + 0 |
| 243 | 7237 | 600 + 0 | 5 + 0 |

DISPLAY OPERATION

(See [Figure 11](#) : on page B-12)

1. HOME - Brings up the home screen (main menu)
2. REMOTE CONTROL - Toggles the remote control
ON / OFF
3. HELP - Displays additional information describing
the function
4. BACK - Goes back to the previous screen
5. SELECTOR KNOB - rotate adjusts values, push
confirms the selected value or choice

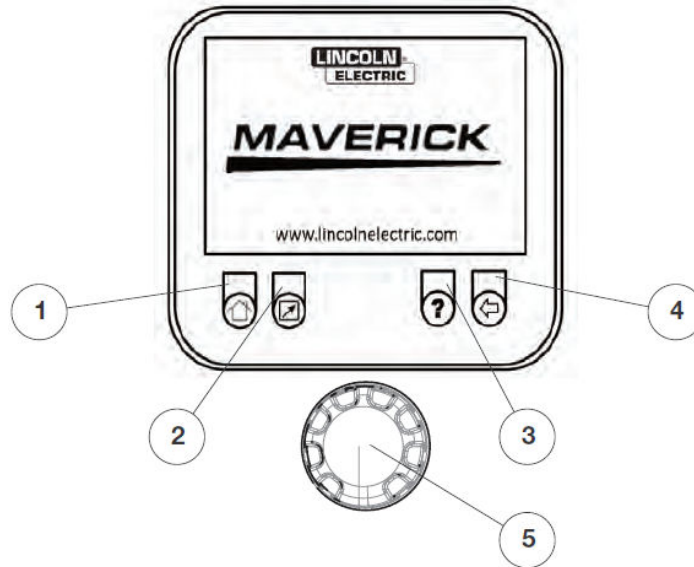
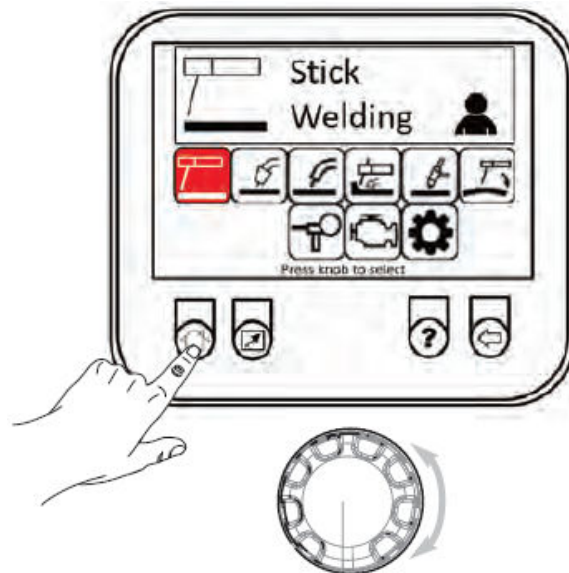

Figure 11 :

Note: When MAVERICK 260X is first started, it will return to the screen that was shown when the machine was turned off.

HOME SCREEN

Pressing the Home button displays the home menu. Rotate the knob to select the desired weld mode, or choose engine options or set-up menu. Push the selector knob to make the selection.



STICK WELDING

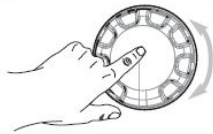
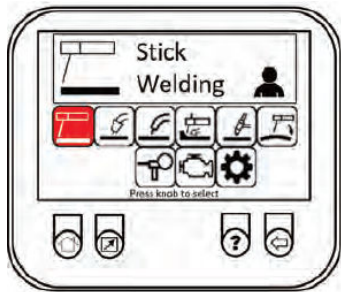

Stick Welding Basic OCV

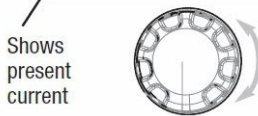
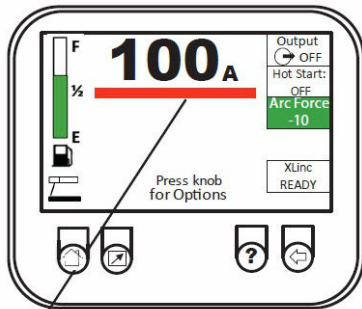

Stick Welding Basic Arc is struck

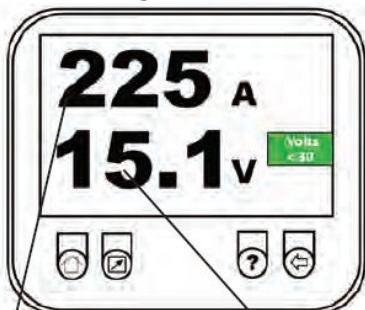

Manual entry operates like a traditional welding machine. Simply set the desired preset amperage or voltage and begin to weld. The "Preset" screen appears when welding is not active. It shows the amount of fuel on the left hand side; the weld mode in the lower left hand corner; the preset value in the middle; and the weld output status in the upper right corner.

Stick Welding Basic OCV w Remote

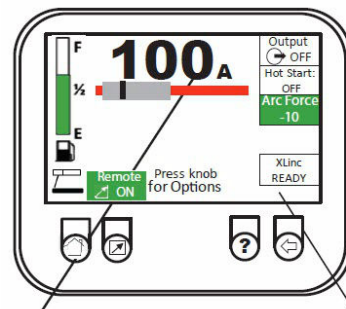

Stick Welding Basic 5 seconds after arc goes out

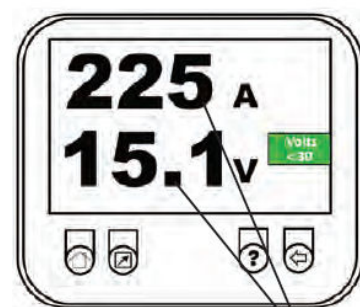

OPERATION

Stick Options

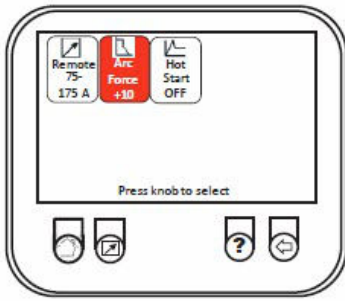

Stick Welding Remote Control

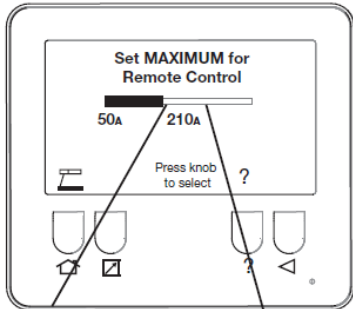

Bar adjusts as number changes

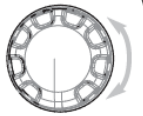

Max current value flashes

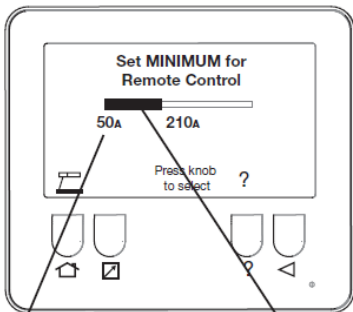

Min current value flashes

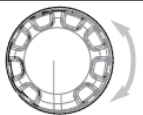

Bar adjusts as number changes

All weld modes support using a remote control like K857-1. Plug the remote into the 6 pin connector on the front of the machine.

Press the remote button on the display to toggle between control at the remote and control at the knob on the machine. The remote button does not function when welding is occurring.

When the remote is enabled, a bar will appear underneath the preset value showing the remote range. The standard range allows the remote to adjust from the minimum to the maximum value of the machine.

Remote Setting - Adjusting the maximum and minimum values of the remote control can improve the remote control sensitivity Example - setting

Stick Welding ARC FORCE

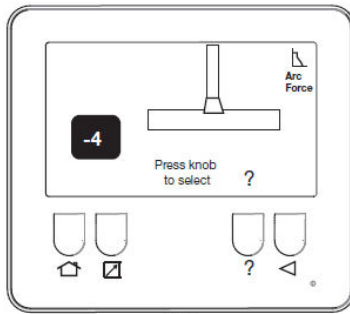

Stick Welding HOT START

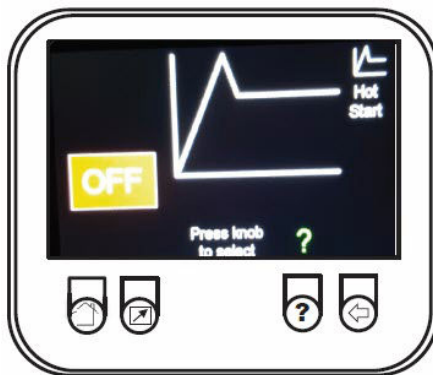

Arc Force - Prevent the electrode from sticking during welding. It provides a temporary increase in current when the arc length becomes very short. Increasing the value from -10 (Soft) to +10 (Crisp) increases the short circuit current and prevents sticking of the electrode to the plate while welding, while decreasing the value reduces the amount of spatter.

Hot Start - is a temporary increase of the output current for approx. 0.5 sec at Stick Welding ARC FORCE the start of the weld. This helps to ignite the arc quickly and reliably without electrode sticking.

MIG/FAW WELDING



MIG Welding Basic OCV

Manual entry operates like a traditional welding machine. Simply set the desired preset amperage or voltage and begin to weld. The "Preset" screen appears when welding is not active. It shows the amount of fuel on the left hand side; the weld mode in the lower left hand corner; the preset value in the middle; and the weld output status in the upper right corner.

Pinch Mode: Pinch also called inductance changes the rate of current rise when the electrode short circuits to work. More pinch may reduce spatter, while less pinch makes the puddle more fluid, resulting in a flatter smoother weld bead.

Hot Start - is a temporary increase of the output current for approx. 0.5 sec at the start of the weld. This helps to ignite the arc quickly and reliably without electrode sticking.

MIG Welding Basic OCV w Remote

OPERATION

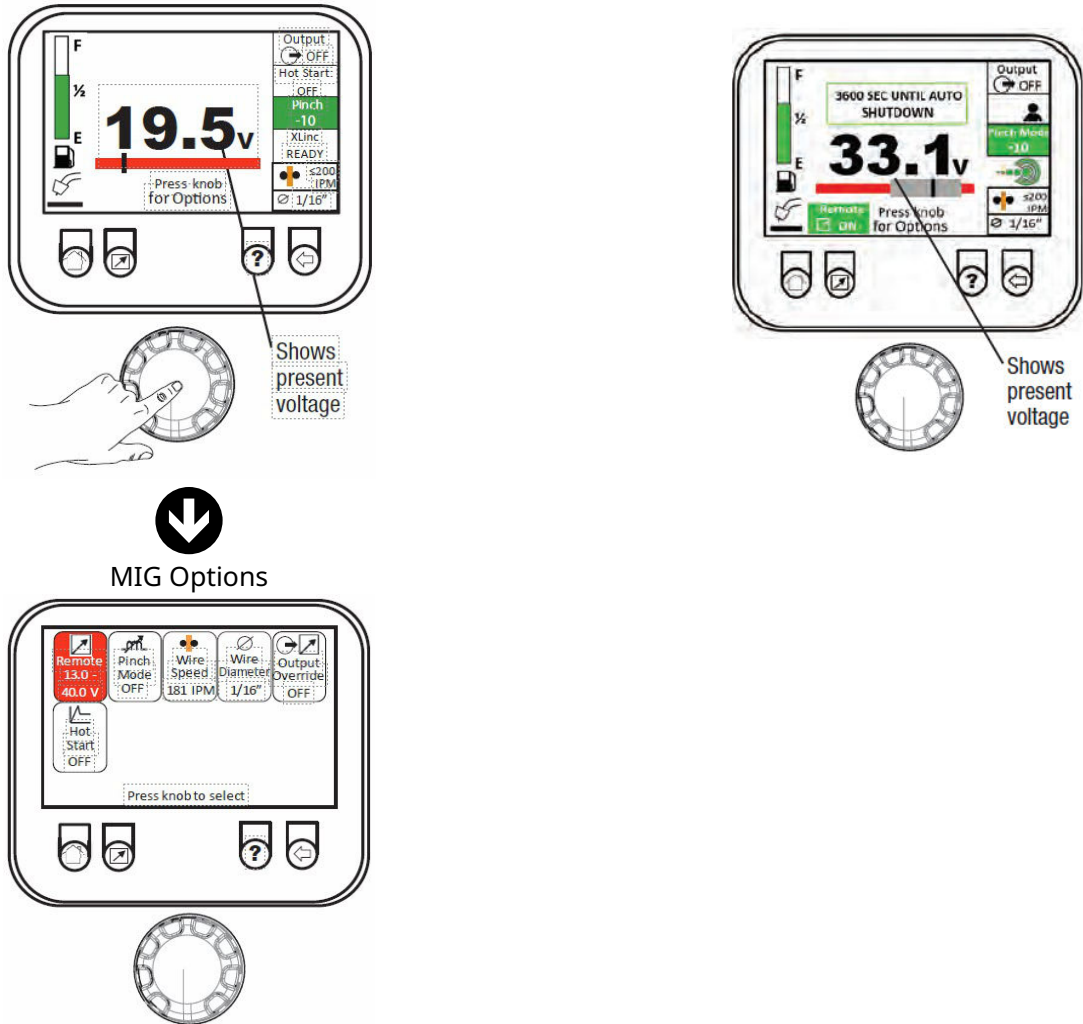

CROSSLINC

CrossLinc provides the benefits of remote control without a cable. The accessory or wire feeder talks to the power source by sending signal through the electrode cable.

To start CrossLinc, simply connect the weld cables and sense lead per the CrossLinc device's instructions. Select the desired weld mode with the MAVERICK 260X. When the weld output is ON the CrossLinc device will automatically link to the MAVERICK 260X. The CrossLinc icon will appear on the screen to show active communication. When CrossLinc is active, the remote control is disabled.

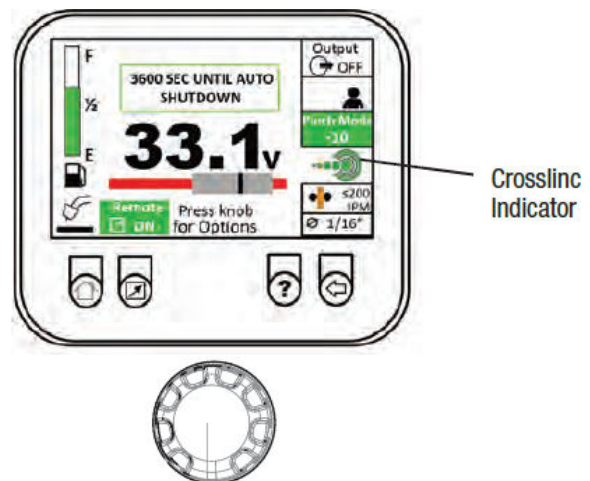

SPOOL GUN

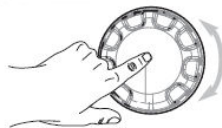

Spool Gun Welding Basic OCV

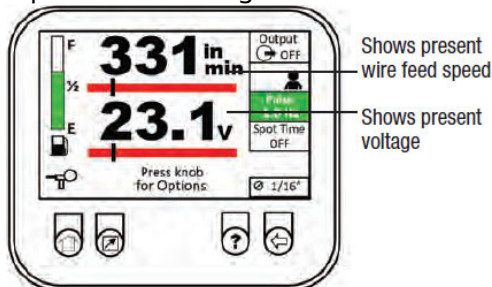

Spool Gun Options

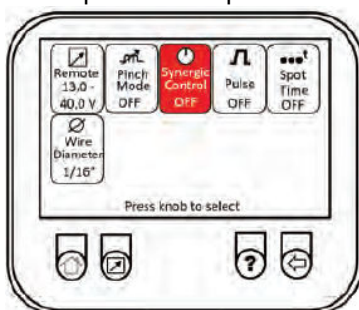

Manual entry operates like a traditional welding machine. Simply set the desired preset amperage or voltage and begin to weld. The “Preset” screen appears when welding is not active. It shows the amount of fuel on the left hand side; the weld mode in the lower left hand corner; the preset value in the middle; and the weld output status in the upper right corner.

Spool Gun Welding Basic OCV w Remote

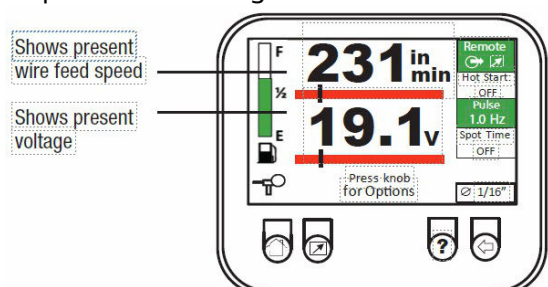

Synergic Control: The spool gun knob adjusts the disposition rate and the Maverick knob sets the arc length. As the disposition rate changes the voltage is automatically adjusted to maintain the same arc length.

Normal Control: The spool gun knob sets the wire feed speed and the Maverick knob sets the voltage.

SPOOL GUN SYNERGIC CONTROL MODE

The spool gun may be either set in “normal” control or “synergic” control. Synergic mode automatically adjusts the voltage when the wire feed speed is changed.

Spool Gun Synergic Control Selection

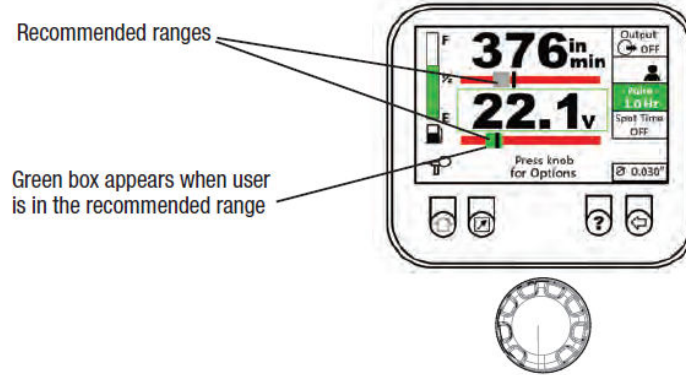

SPOOL GUN PULSE MODE

Activating Spool Gun Pulse toggles both the voltage and wire feed speed between a peak and a low level. It is useful for lower heat input welding and creating the appearance of “stacked dimes” in aluminum.

Pulse Mode

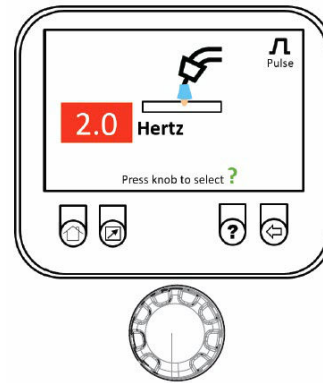

SPOT TIME MODE

Spot Time Mode

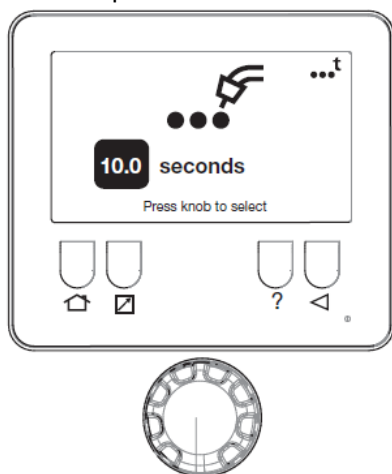

Spot Time is useful for making multiple welds of a similar size. Popular applications are when welding on thin material to control heat input, and to make consistent sized tack welds. When spot time is enabled, welding continues for the period of time chosen, as long as the trigger is pulled. Welding stops when the time is exceeded, even if the trigger remains pulled. Release the trigger and pull again to make another weld.

ENGINE STATUS SCREEN

The Engine Status screen provides information about the engine servicing and operation.

Five parts of the engine are monitored for service: Oil, Coolant, Air Filter, Fan Belt and Fuel Filter. To view detailed information about an item, rotate the knob until the item is highlighted in red. The top of the screen displays the number of hours remaining until service is required for the selected item.

The red/yellow/green bars for each item indicate how much time is left.

- Green = Normal operation
- Yellow = Service is required soon
- Red = Service is overdue

After service has been performed on an item, press and hold the knob for 5 seconds to reset the service interval timer.

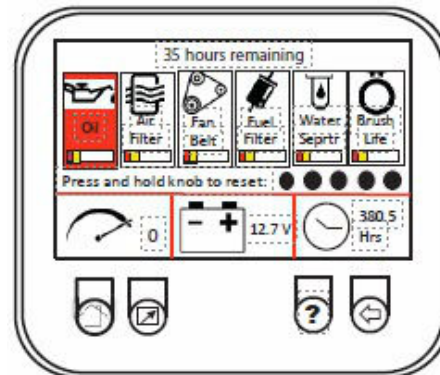
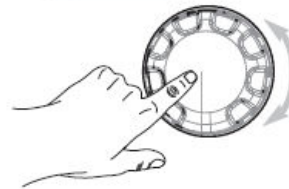
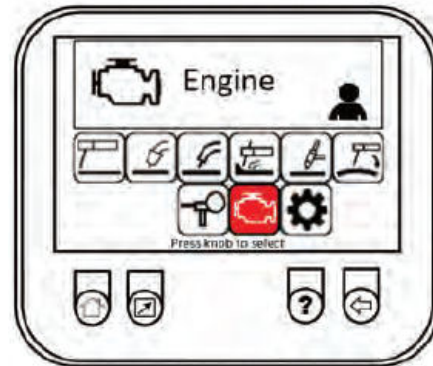

ENGINE INFORMATION

The user can bring up the Engine Information screen by pressing the “?” button while on the landing page in any welding mode. In order to exit the Engine Information screen, press the back button or the encoder knob. The user may press the home button to return to the weld mode selection.

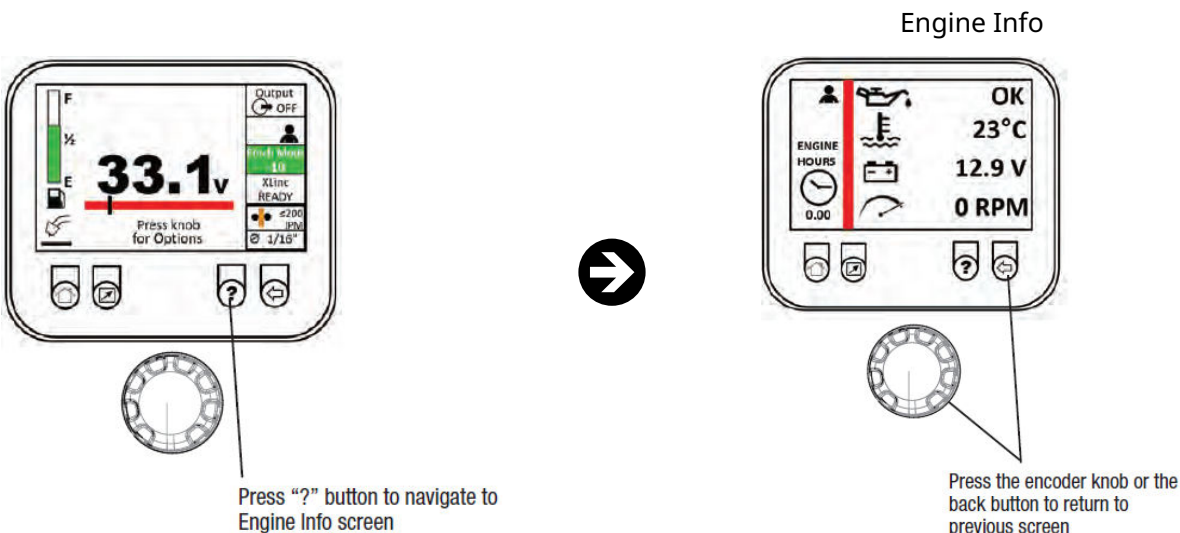

SET-UP

The set-up allows for customization of the MAVERICK 260X. Options available in the Set-up menu are:

- **AUTO-START: NO LOAD PERIOD** - When AUTO-START is enabled, the NO LOAD PERIOD is the period of time the machine can be running with no auxiliary or weld load before it automatically shuts down. The user can use this setting to set the amount of time for the NO LOAD PERIOD.
- **TAP START ACTIVE PERIOD** - The TAP START ACTIVE PERIOD is the period of time that the user can restart the welder after it is shut down due to the NO LOAD PERIOD when AUTO-START is enabled. In order to restart the welder, tap the electrode to the work piece. This setting is used to set the TAP START ACTIVE PERIOD time.
- **AUTO-START: ON/OFF** - AUTO-START shuts down the engine when it is not in use for a set period of time and allows the user to re-start the engine with a "tap" of their electrode onto their work piece without having to go back to their machine.
- **PIN** - PIN page is used to set and enable a mandatory Operator Pin when the machine is turned on and/or a Supervisor Pin for accessing the Setup page.
- **DISPLAY BRIGHTNESS**
- **DIAGNOSTIC INFORMATION** - Diagnostic information page can be used to get useful information about the welder. ECG FAULT CODE is the number of pulse detected from ECG fault lamp. The fault codes can be found in troubleshooting section.
- **NEW PCB CALIBRATION** - When new PCB is installed on the machine, calibration is needed. To ensure proper calibration ensure mode was in Stick at 150 amps set point before entering setup menu. Failure to do so will not allow welder to enter calibration mode.
- **RESTORE FACTORY SETTINGS**
- **MACHINE SELECT** - When a new PCB is installed on the machine, the PCB has to go through a "Machine Select" process. This setup option should only be used if the initial "Machine Select" process was not completed successfully. To enter this setup option use the following pass code: 3210. Ensure the correct K # and Code number is used for the machine. Failure to do so can permanently damage the welder.

OPERATION

- **CROSSLINC ON/OFF**
- **SPOOL GUN CALIBRATION** - When first connecting a spool gun to the machine, the engine power must be calibrated for the spool gun to have the wire feed speed be accurate.
- **ENGINE SERVICE KIT** - Provides useful information regarding replacement parts needed during the service of the MAVERICK 260X.
- **PRODUCTIVITY METRICS** - Provides useful information and statistics regarding how the machine is being used.

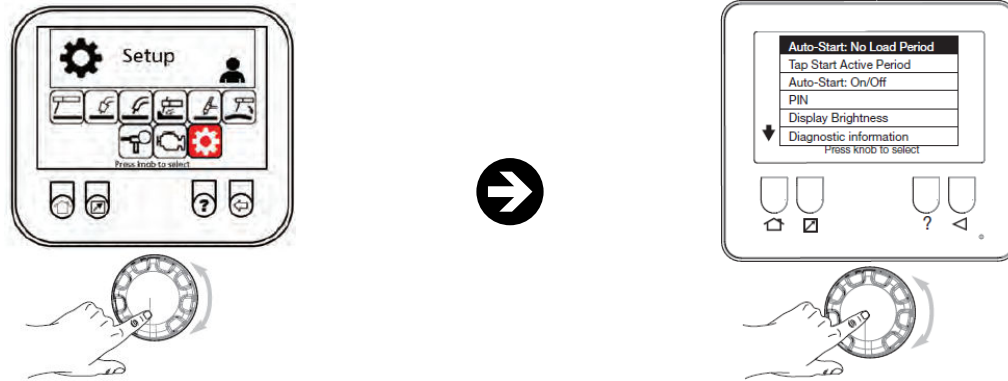

TEMPERATURE UNITS: Choice between (F) Fahrenheit or (C) Celsius.

MEASUREMENT UNITS: Choice between Imperial or Metric units.

LANGUAGE SELECTION: Choice of English, French or Spanish.

UPDATE FIRMWARE: Update by uploading new firmware by the USB port.

PIN

DO NOT FORGET THE PIN! The PIN may only be reset by a Lincoln Authorized Service Shop.

To turn on Operator security, rotate the knob until Operator PIN is highlighted and press the knob.

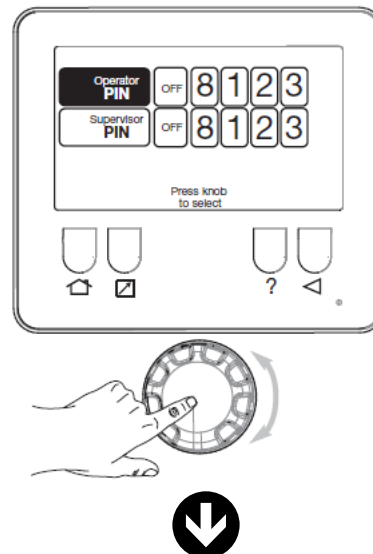

Rotate the knob to turn the PIN on or off. Press the knob to select.

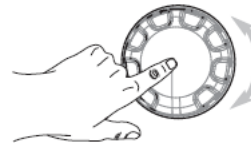
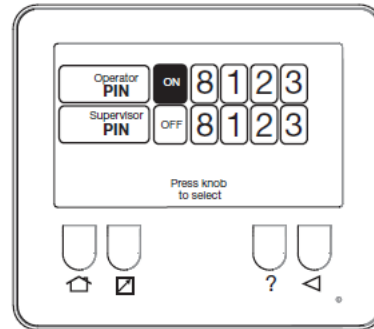

Rotate the knob to adjust the value of the PIN. Press the knob to advance to the next number. Press the BACK button to go the previous number.

Entry of the Supervisor PIN is similar to the Operator PIN.

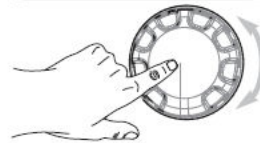
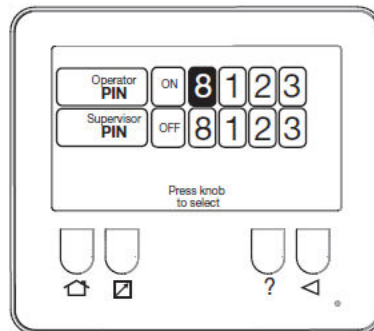

MACHINE SELECT

Access the machine select feature only when replacing a pc board in the welder. Go to SETUP menu from the home page. Scroll through the menu items select machine setup.

Enter the correct K# and Code # for the welder the PCB is being installed on. K# and Code # can be found above the top name plate("Machine Information Above"). Failure to enter the correct K# and Code # may result in permanent damage to the welder.

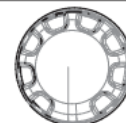
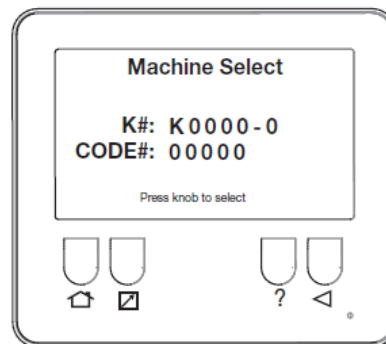

OPERATION

If correct k # and Code # entered. The Welder will be accepted.

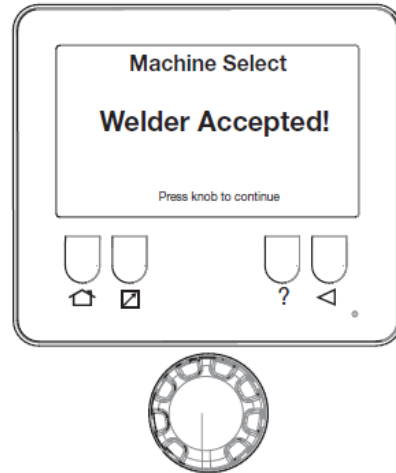

SPOOL GUN CALIBRATION

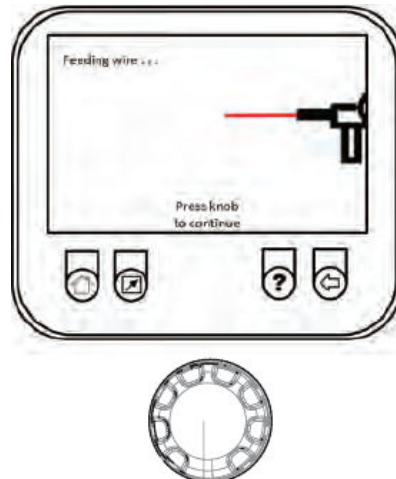
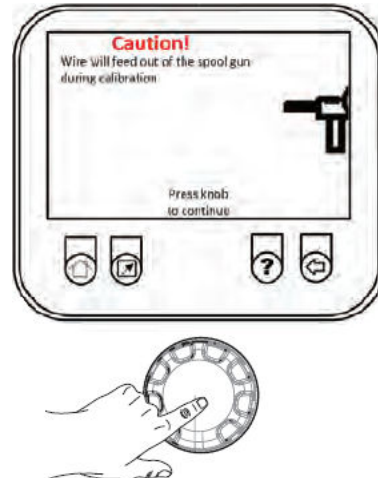
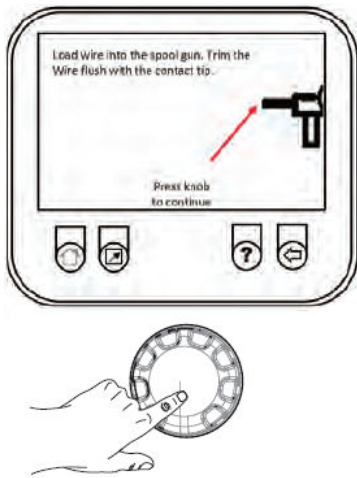

This screen will remain for approximately 5 seconds as the wire feeds. During this process, the wire coming out of the spool gun will grow longer as a visual representative.

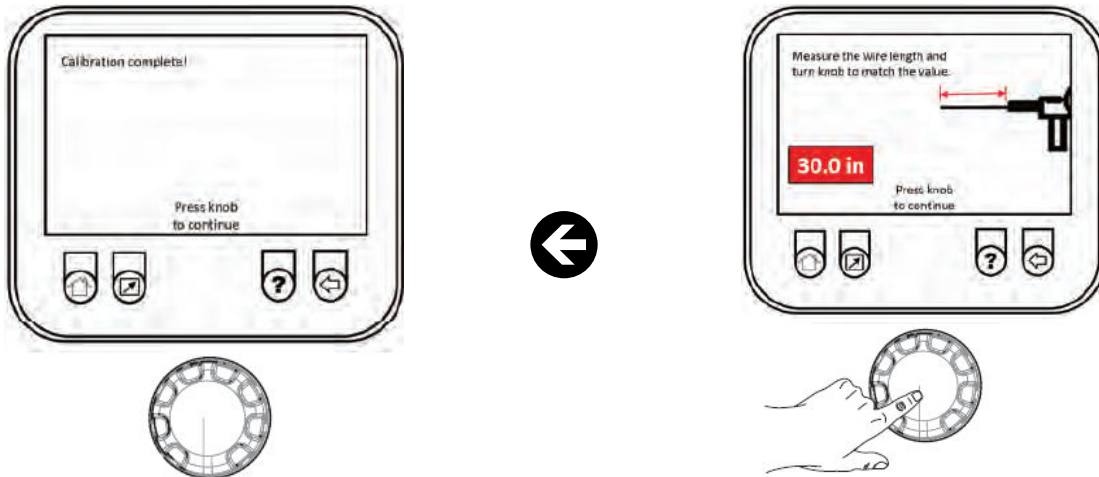

ENGINE SERVICE KIT

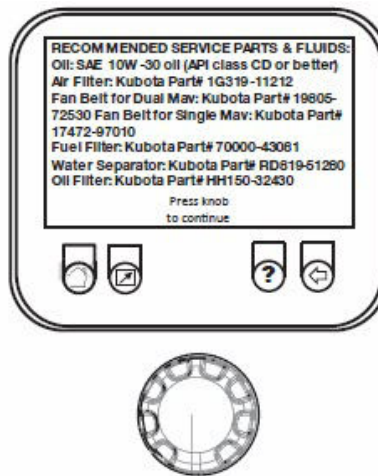

PRODUCTIVITY METRICS

The Productivity Metrics screen provides information and statistics on how the machine is being utilized.

Five statistics of the machine are monitored: Arc Hours, Auxiliary Hours, Utilization Percent, Standby Hours and Fuel Saved w/ Auto- Start.

Arc Hours is the time spent using the machine for welding.

Auxiliary Hours is the time spent using the auxiliary power on the machine.

Utilization Percent represents how efficiently the machine is being used. It shows the percentage of time the machine is being loaded with respect to the total hours on the engine.

Standby Hours is the time the machine was running while not being loaded.

Fuel Saved w/ Auto-Start is the amount of fuel in US gallons that has been saved due to the Auto-Start feature.

To view information regarding one of the monitored parameters, rotate the knob until the desired item is highlighted in red. The bottom of the screen shows the value of the parameter on the longer left side portion, and located in the bottom right corner is the engine hours.

In order to reset any of these metrics, press and hold the knob on the selected parameter for 5 seconds.

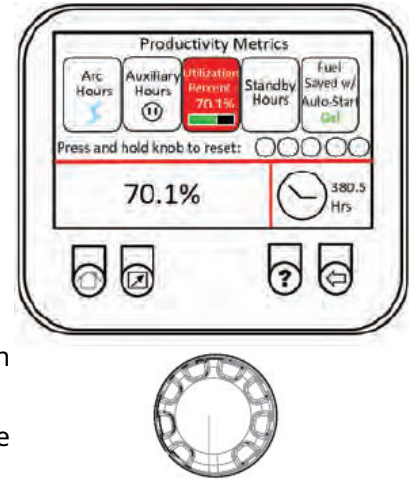

ACCESSORIES AND OPTIONS

MAVERICK 260X ACCESSORIES

OPTIONAL FIELD INSTALLED ACCESSORIES

K2639-1 Fender Kit

K2640-1 Cable Rack

K2635-1 Four Wheel Trailer

K857 Remote Control

K857-1 Remote Control

K2613-5A1 Ln-25 PRO with K126 PRO Gun

K126-12 K126 PRO Gun

KP1696-068 Drive Roll Kit

K12038-2 Invertec PC610 Plasma

K12048-1 Tomahawk 1025 Plasma

K1770-2 Factory Undercarriage - Pneumatic

K3519-1Activ8X

Rugged, light-weight, portable across-the-arc wire feeder that fits up to an 8" diameter spool. Includes CrossLinc and TVT capability to remotely set voltage from the feeder without a control cable and to ensure the set voltage regardless of power cable lengths.

K4717-1 Activ8X Pipe

Ideal pipeline solution for GMAW and FCAW welding applications in a rugged and compact design. Features root-to-cap weld processes - including STT and Pulsed MIG - specifically optimized for cross country pipe welding.

Note: Power limited to 7.3KW weld output when used with MAVERICK 260X welder.

ACCESSORIES AND OPTIONS

MAINTENANCE

SAFETY PRECAUTIONS

WARNING



- Have qualified personnel do all maintenance and troubleshooting work.
 - Turn the engine off before working inside the machine or servicing the engine.
 - Remove guards only when necessary to perform maintenance and replace them when the maintenance requiring their removal is complete. If guards are missing from the machine, obtain replacements from a Lincoln Distributor. (See Operating Manual Parts List.)
- Read the Safety Precautions in the front of this manual and in the Engine Owner's Manual before working on this machine.
- Keep all equipment safety guards, covers, and devices in position and in good repair. Keep hands, hair, clothing, and tools away from the gears, fans, and all other moving parts when starting, operating, or repairing the equipment.

ROUTINE AND PERIODIC MAINTENANCE

Daily

- Check the Engine oil levels.
- Refill the fuel tank to minimize moisture condensation in the tank.
- Open the water drain valve located on the bottom of the water separator element 1 or 2 turns and allow to drain into a container suitable for diesel fuel for 2 to 3 seconds. Repeat the above drainage procedure until diesel fuel is detected in the container
- Check coolant level in the coolant recovery bottle. If full empty bottle.

Weekly

Blow out the machine with low pressure air periodically. In particularly dirty locations, and the radiator, this may be required once a week.

ENGINE MAINTENANCE

Refer to the "Periodic Checks" section of the Engine Operator's Manual for the recommended maintenance schedule of the following:

- a) Engine Oil and Filter
- b) Air Cleaner
- c) Fuel Filter - and Delivery System
- d) Alternator Belt
- e) Battery
- f) Cooling System

Refer to [Table 5](#) : on page D-2 for various engine maintenance components.



MAINTENANCE

Table 5 :

| REPLACEMENT SERVICE ITEMS | | | |
|---------------------------|--------|-----------------------------|---|
| ITEM | MAKE | PART NUMBER | SERVICE INTERVAL |
| AIR CLEANER ELEMENT | KUBOTA | 1G659-11220 ⁽¹⁾ | Clean every 100 hours Replace every year or every 6 cleanings. |
| FAN BELT | KUBOTA | 19805-72530 | Replace every 500 hours. |
| OIL FILTER | KUBOTA | HH1 J0-32430 ⁽¹⁾ | Replace every 300 hours. |
| WATER SEPARATOR ELEMENT | KUBOTA | RD819-51280 ⁽¹⁾ | Replace / Clean every 400 hours. |
| FUEL FILTER | KUBOTA | 15221-43170 ⁽¹⁾ | Replace every 400 hours. |
| BATTERY | | BCI GROUP 99 | Inspect every 500 hours. |

Note: ⁽¹⁾ Item included in K3599-7 engine service kit.

AIR FILTER

| | |
|--|--|
|  CAUTION | |
|  | Excessive air filter restriction will result in reduced engine life. |

| | |
|--|--|
|  WARNING | |
|  | Never use gasoline or low flash point solvents for cleaning the air cleaner element. A fire or explosion could result. |

| | |
|--|---|
|  CAUTION | |
|  | Never run the engine without the air cleaner. Rapid engine wear will result from contaminants, such as dust and dirt being drawn into the engine. |

The diesel engine is equipped with a dry type air filter. Never apply oil to it. Service the air cleaner as follows:

Replace the element as indicated by the service indicator. (See Service Instructions and Installation Tips for Engine Air Filter.)

AIR FILTER SERVICE INSTRUCTIONS

Single- and Two-Stage Engine Air Cleaners

1 REMOVE THE FILTER

Unfasten or unlatch the service cover. Because the filter fits tightly over the outlet tube to create the critical seal, there will be some initial resistance, similar to breaking the seal on a jar. Gently move the end of the filter back and forth to break the seal then rotate while pulling straight out. Avoid knocking the filter against the housing.



Rotate the filter while pulling straight out.

If your air cleaner has a safety filter, replace it every third primary filter change. Remove the safety filter as you would the primary filter. Make sure you cover the air cleaner outlet tube to avoid any unfiltered contaminant dropping into the engine.

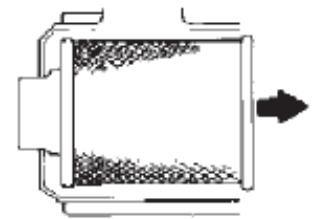

2 Clean Both Surfaces of the Outlet Tube and Check the Vacuator™ Valve

Use a clean cloth to wipe the filter sealing surface and the inside of the outlet tube. Contaminant on the sealing surface could hinder an effective seal and cause leakage. Make sure that all contaminant is removed before the new filter is inserted. Dirt accidentally transferred to the inside of the outlet tube will reach the engine and cause wear. Engine manufacturers say that it takes only a few grams of dirt to "dust" an engine! Be careful not to damage the sealing area on the tube.

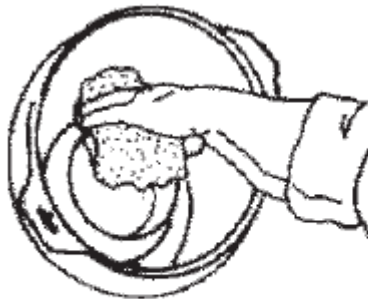

Outer edge of the outlet tube

Wipe both sides of the outlet tube clean.

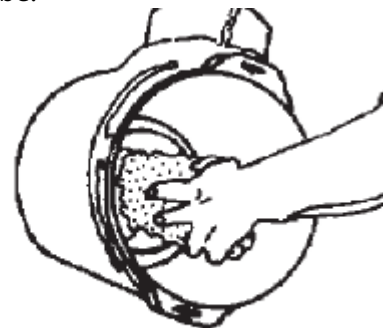

Inner edge of the outlet tube

If your air cleaner is equipped with a Vacuator Valve

Visually check and physically squeeze to make sure the valve is flexible and not inverted, damaged or plugged.



3 Inspect the Old Filter for Leak Clues

Visually inspect the old filter for any signs of leaks. A streak of dust on the clean side of the filter is a telltale sign. Remove any cause of leaks before installing new filter.

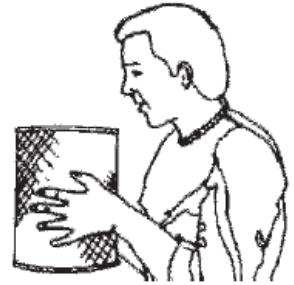

4 Inspect the New Filter for Damage

Inspect the new filter carefully, paying attention to the inside of the open end, which is the sealing area. NEVER install a damaged filter. A new Donaldson radial seal filter may have a dry lubricant on the seal to aid installation.

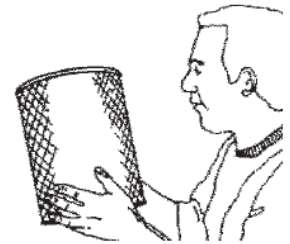

5 Insert the New Radial Seal Filter Properly

If you're servicing the safety filter, this should be seated into position before installing the primary filter.

Insert the new filter carefully. Seat the filter by hand, making certain it is completely into the air cleaner housing before securing the cover in place. The critical sealing area will stretch slightly, adjust itself and distribute the sealing pressure evenly. To complete a tight seal, apply pressure by hand at the outer rim of the filter, not the flexible center. (Avoid pushing on the center of the urethane end cap.) No cover pressure is required to hold the seal. NEVER use the service cover to push the filter into place! Using the cover to push the filter in could cause damage to the housing, cover fasteners and will void the warranty.

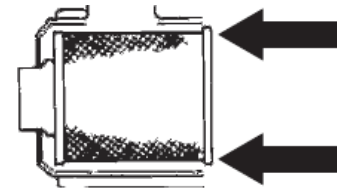

If the service cover hits the filter before it is fully in place, remove the cover and push the filter (by hand) further into the air cleaner and try again. The cover should go on with no extra force.

Once the filter is in place, secure the service cover.

CAUTION



NEVER use the service cover to push the filter into place! Using the cover to push the filter in could fasteners and will void the warranty.

6 Check Connectors for Tight Fit

Make sure that all mounting bands, clamps, bolts, and connections in the entire air cleaner system are tight. Check for holes in piping and repair if needed. Any leaks in your intake piping will send dust directly to the engine!

FUEL FILTERS
 **WARNING**

When working on the fuel system:

- Keep naked lights away, do not smoke!
- Do not spill fuel!

The MAVERICK 260X is equipped with a Fuel Filter located to left of air cleaner. The procedure for changing the filter is as follows.

1. Close the fuel shutoff valve located in front of the fuel filter.
2. Clean the area around the fuel filter head. Remove the filter. Clean the gasket surface of the filter head and replace the o-ring.
3. Fill the clean filter with clean fuel, and lubricate the o-ring seal with clean lubricating oil.
4. Install the filter as specified by the filter manufacturer.

 **WARNING**

Mechanical over tightening will distort the threads, filter element seal or filter can.

COOLING SYSTEM

The MAVERICK 260X is equipped with a pressure radiator. Keep the radiator cap tight to prevent loss of coolant. Clean and flush the coolant system periodically to prevent clogging the passage and over-heating the engine. When antifreeze is needed, always use the permanent type.

- Every 500 hours check radiator to ensure there is no fin blockage or leaks. Clean as necessary with an environmentally friendly degreaser and low pressure water.
- • When draining the entire contents of the system, remove radiator cap. Pull drain hose through the battery access door in the base and open shut off valve until system is empty.
- When refilling, close shut off valve on drain hose.

NAMEPLATES / WARNING DECALS MAINTENANCE

Whenever routine maintenance is performed on this machine - or at least yearly - inspect all nameplates and labels for legibility. Replace those which are no longer clear. Refer to the parts list for the replacement item number.

WELDER / GENERATOR MAINTENANCE
Storage

Store the MAVERICK 260X in clean, dry, protected areas.

Cleaning

Blow out the generator and controls periodically with low pressure air. Do this at least once a week in particularly dirty areas.

FAN BELT CHANGE

When changing the fan belt, ensure the replacement fan is 34.5 inches, cogged style.

Proper fan belt tension is a deflection of between 7 to 9 mm (0.28 to 0.35 in.) when the belt is pressed in the middle of the span.

To apply the proper fan belt tension:

1. Stop the engine.
2. Apply moderate thumb pressure to belt between the pulleys.
3. If tension is incorrect, loosen the alternator mounting bolts and, using a lever placed between the alternator and the engine block, pull the alternator out until the deflection of the belt falls within acceptable limits.
4. Replace fan belt if damaged.

Note: If belt is loosen or damaged and the fan is damaged, it could result in overheats or insufficient charging. Correct or replace belt.

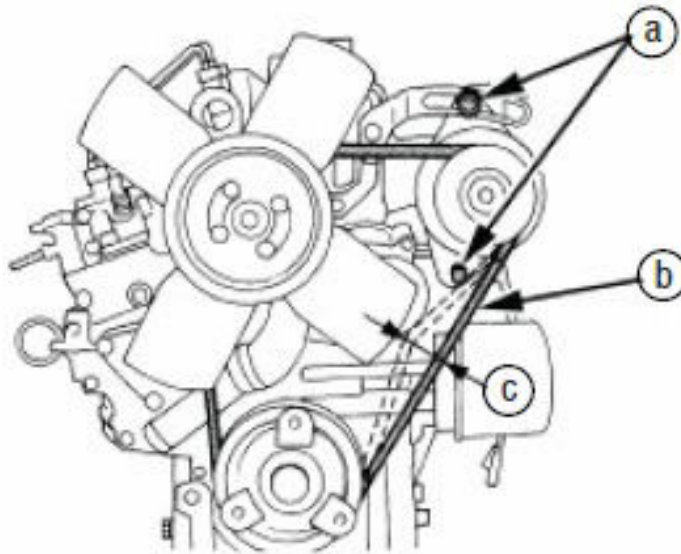

- a. Bolt and nut
- b. Fan belt
- c. 7 to 9 mm (0.28 to 0.35 in.) under load of 10 kgf (22.1 lbs.)

OIL CHANGE

Remove battery cover (picture to the right) and route oil drain hose through opening to change engine oil.

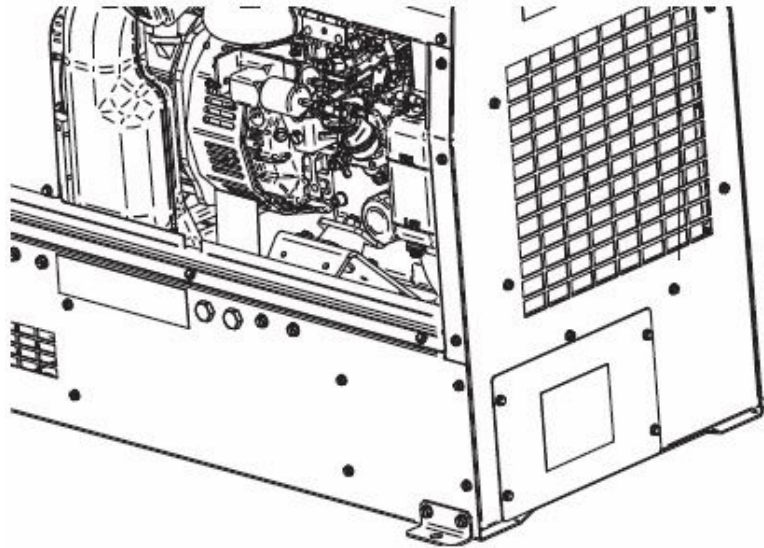

BATTERY HANDLING

WARNING



GASES FROM BATTERY can explode.

- Keep sparks, flame, and cigarettes away from battery.

WARNING



To prevent EXPLOSION when:

- **INSTALLING A NEW BATTERY** - disconnect negative cable from the old battery first and connect to new battery last.
- **CONNECTING A BATTERY CHARGER** - Remove battery from welder by disconnecting negative cable first, then the positive cable and battery clamp. When reinstalling, connect negative cable last. Keep well ventilated.
- **USING A BOOSTER** - connect the positive lead to the battery first, then connect negative lead to engine foot.

 **WARNING**



BATTERY ACID CAN BURN EYES AND SKIN.

- Wear gloves and eye protection and be careful when working near battery. Follow instructions printed on battery.

PREVENTING ELECTRICAL DAMAGE

1. When replacing, jumping, or otherwise connecting the battery to the battery cables, the proper polarity must be observed. Failure to observe the proper polarity could result in damage to the charging circuit. The positive (+) battery cable has a red terminal cover.
2. If the battery requires charging from an external charger, disconnect the negative battery cable first and then the positive battery cable before attaching the charger leads. Failure to do so can result in damage to the internal charger components. When reconnecting the cables, connect the positive cable first and negative cable last.

PREVENTING BATTERY DISCHARGE

Turn the RUN/STOP switch to stop when engine is not running.

PREVENTING BATTERY BUCKLING

Tighten nuts on battery clamp until snug.

CHARGING THE BATTERY

When you charge, jump, replace, or otherwise connect battery cables to the battery, be sure the polarity is correct. Improper polarity can damage the charging circuit. The MAVERICK 260X positive (+) battery terminal has a red terminal cover.

If you need to charge the battery with an external charger, disconnect the negative cable first, then the positive cable before you attach the charger leads.

After the battery is charged, reconnect the positive battery cable first and the negative cable last. Failure to do so can result in damage to the internal charger components.

Follow the instructions of the battery charger manufacturer for proper charger settings and charging time.

WELDER GENERATOR MAINTENANCE

Blow out the generator and controls periodically with low pressure compressed air.

BRUSH REMOVAL AND REPLACEMENT**⚠ WARNING**

Do not attempt to polish slip rings while the engine is running

• Service and repair should only be performed by Lincoln Electric Factory Trained Personnel. Unauthorized repairs may result in danger to technician and machine operator and will invalidate your factory warranty. For your safety and to avoid Electric Shock, please observe all safety notes and precautions.

It is normal for the brushes and slip rings to wear and darken slightly. Inspect the brushes every 3 months or 200 hours, whichever comes first.

1. Disconnect the negative battery lead.
2. Remove six screws that hold the front panel.
3. Remove leads (200 & 219) from the brush holder.
4. Using a 10mm wrench, remove the two screws securing the brush holder assembly. Lift the brush holder assembly up and then out.
5. Examine the brushes for chips, cracks or excess or uneven wear. The brush should be at least $\frac{1}{4}$ " long. Verify the brush springs are operating and are not stuck. Replace the brush assembly as "needed". Inspect the rotor slip rings for grooves and excess wear.
6. Replace with new brush & brush holder assembly, reconnect the leads 200 on the (+) positive brush, place lead 219 on the (-) negative brush. Tighten the bolts to 41 in lbs.

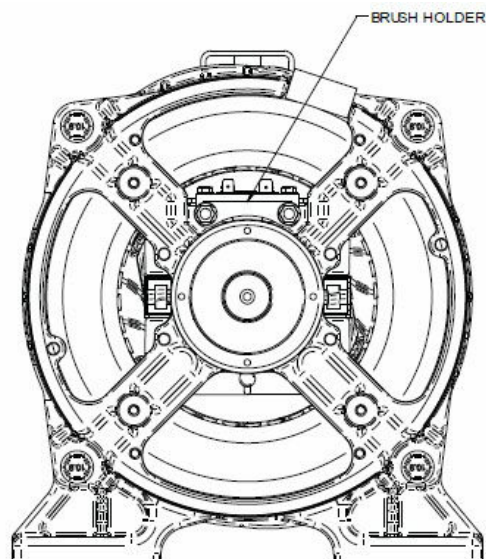

TROUBLESHOOTING

HOW TO USE TROUBLESHOOTING GUIDE

WARNING



Service and Repair should only be performed by Lincoln Electric Factory Trained Personnel. Unauthorized repairs performed on this equipment may result in danger to the technician and machine operator and will invalidate your factory warranty. For your safety and to avoid Electrical Shock, please observe all safety notes and precautions detailed throughout this manual.

This Troubleshooting Guide is provided to help you locate and repair possible machine malfunctions. Simply follow the three-step procedure listed below.

- 1. LOCATE PROBLEM (SYMPTOM)**-Look under the column labeled "PROBLEM (SYMPTOMS)". This column describes possible symptoms that the machine may exhibit. Find the listing that best describes the symptom that the machine is exhibiting.
- 2. POSSIBLE CAUSE**- The second column labeled "POSSIBLE CAUSE" lists the obvious external possibilities that may contribute to the machine symptom.
- 3. RECOMMENDED COURSE OF ACTION**- This column provides a course of action for the Possible Cause, generally it states to contact your local Lincoln Authorized Field Service Facility.

If you do not understand or are unable to perform the Recommended Course of Action safely, contact your local Lincoln Authorized Field Service Facility.

WARNING



ELECTRIC SHOCK can kill.

Turn off machine at the disconnect switch on the rear of the machine and remove main power supply connections before doing any troubleshooting.

ATTENTION



If for any reason you do not understand the test procedures or are unable to perform the tests/repairs safely, contact your Lincoln Authorized Service Facility for technical troubleshooting assistance before you proceed.

<https://www.lincolnelectric.com/locator>

TROUBLESHOOTING GUIDE

Observe all Safety Guidelines detailed throughout this manual

| PROBLEMS (SYMPTOMS) | POSSIBLE CAUSE | RECOMMENDED COURSE OF ACTION |
|--|---|--|
| AUXILIARY OUTPUT | | |
| No auxiliary power. | <ol style="list-style-type: none"> 1. Check that the circuit breakers did not trip. 2. Check that the GCFI has not tripped. 3. Check brushes. | If all recommended possible areas of misadjustment have been checked and the problem persists, contact your local Lincoln Authorized Field Service Facility. |
| ENGINE | | |
| Engine will not crank. | <ol style="list-style-type: none"> 1. Low or weak battery. 2. Inspect for loose or corroded battery terminals. 3. "Battery circuit" circuit breaker (CB4) has tripped. Located on front control panel. 4. Faulty starter motor. | If all recommended possible areas of misadjustment have been checked and the problem persists, contact your local Lincoln Authorized Field Service Facility. |
| Engine will crank but not start. | <ol style="list-style-type: none"> 1. Out of fuel. 2. Enter correct security PIN if the PIN function is enabled. 3. Fuel pump not working. 4. Water separator valve closed. | |
| Engine shuts down shortly after starting. | <ol style="list-style-type: none"> 1. Low fuel level. 2. Low oil level. 3. Clogged fuel filter. Clean. 4. Faulty oil pressure switch. | |
| Engine has low output. | <ol style="list-style-type: none"> 1. Low fuel. 2. Clogged fuel filter. 3. Clogged air filter. 4. Poor quality fuel - fuel has sat for a long time. | |
| Engine will not go to low idle. | <ol style="list-style-type: none"> 1. Idler switch is in the High Idle position. 2. Aux load might be on. 3. Faulty PC board. | |
| Engine does not go to full power when using auxiliary power. | <ol style="list-style-type: none"> 1. The auxiliary power load is less than 100 Watts. Set the idle switch to High Idle. 2. Disconnect / turn off auxiliary power loads before starting the engine. | |

| PROBLEMS (SYMPTOMS) | POSSIBLE CAUSE | RECOMMENDED COURSE OF ACTION |
|---|--|---|
| WELDING | | |
| No weld output. | <ol style="list-style-type: none"> 1. Verify the weld output is ON. A green icon with "Output ON" appears in the upper right corner of the screen whenever weld output is ON. 2. Verify the work connection is tight and attached clean base metal. 3. If in CV mode check that "CV TRIGGER OVERRIDE" is not set to "REMOTE". 4. Faulty PC board. 5. Check brushes. | <p>If all recommended possible areas of misadjustment have been checked and the problem persists, contact your local Lincoln Authorized Field Service Facility.</p> |
| No output control at the front panel. | <ol style="list-style-type: none"> 1. Verify the remote control is not turned on. "Remote ON" appears on the bottom left of the screen whenever the remote is turned on. 2. Faulty encoder, replace. | |
| No output control with remote. | <ol style="list-style-type: none"> 1. Verify the remote control is turned on. "Remote ON" appears on the display screen. | |
| Output control range is limited while using a remote. | <ol style="list-style-type: none"> 1. In the weld mode, go to the remote screen and change the scaling of the remote. Ensure amphenol is fully seated and screwed in. | |
| The arc is not stable. | <ol style="list-style-type: none"> 1. Verify the polarity of the electrode and weld cables. 2. Cables may be excessively long, undersized or damaged. 3. Verify the weld settings match the electrode. | |
| VRD (Volts<30) not showing on the display. | <ol style="list-style-type: none"> 1. Ensure VRD ON/OFF switch on the PCB is switched UP to turn the VRD "ON". 2. Faulty PC board. | |
| Display screen shows "Lost Communication" or is BLANK when ignition is turned ON. | <ol style="list-style-type: none"> 1. 12V battery voltage is below 10V. | |

TROUBLESHOOTING

WIRING DIAGRAM

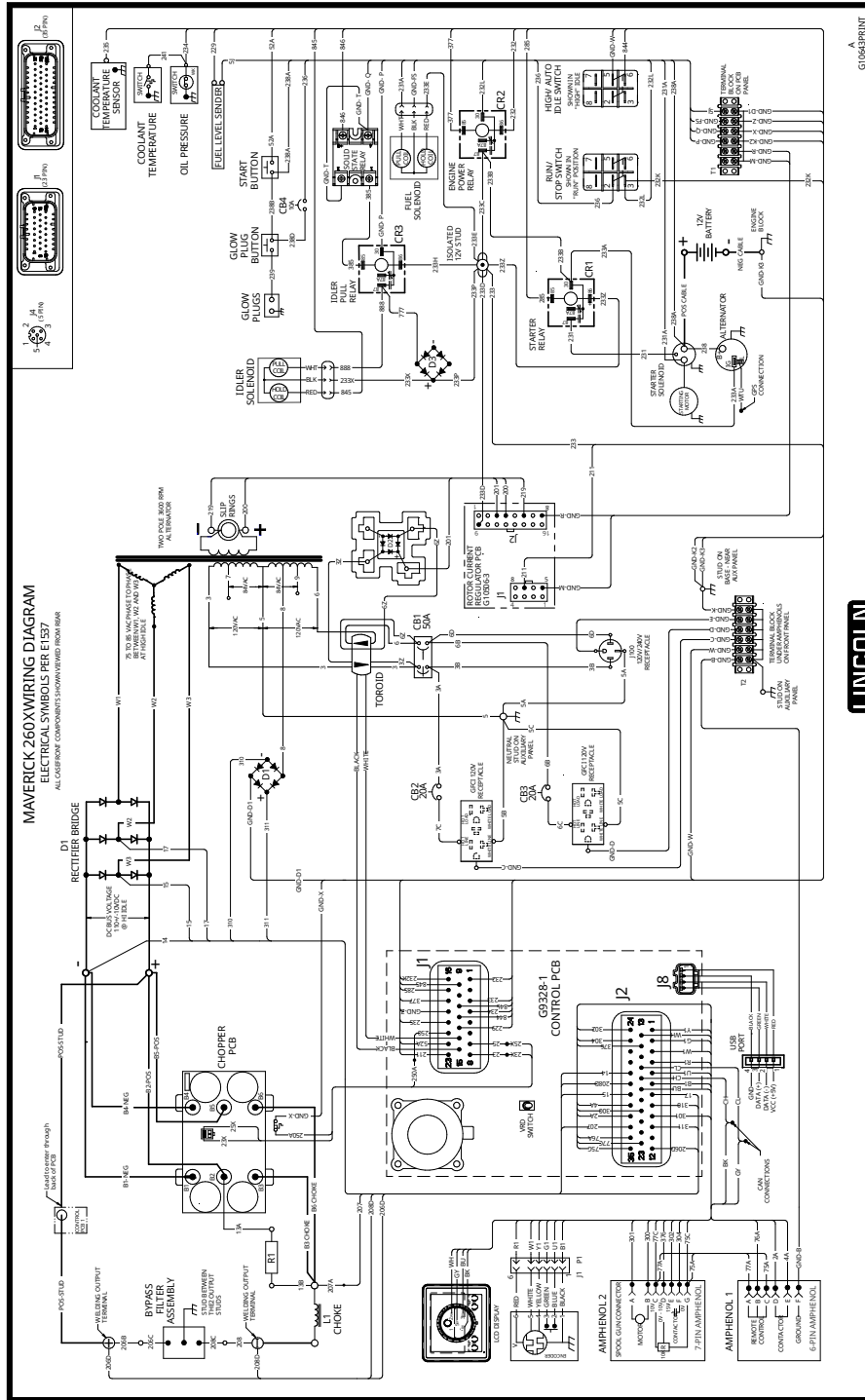

**LINCOLN
ELECTRIC**

A
G066SPRINT

DIMENSION PRINT

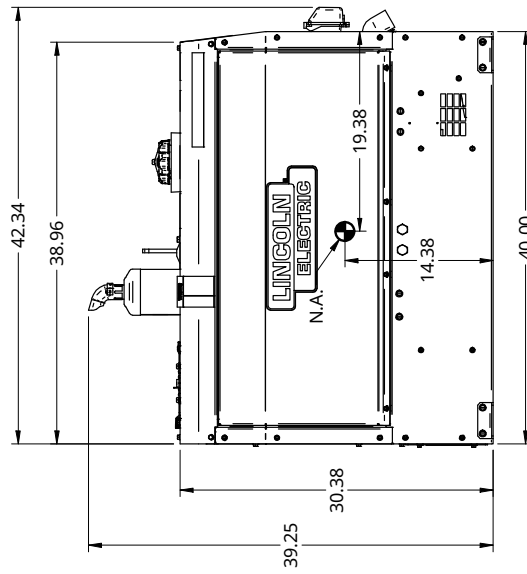
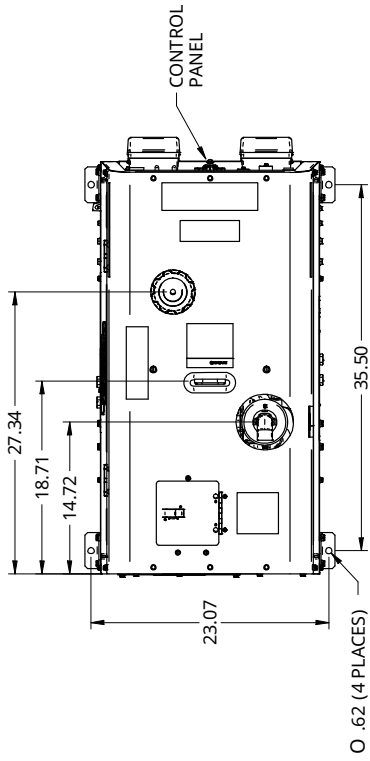
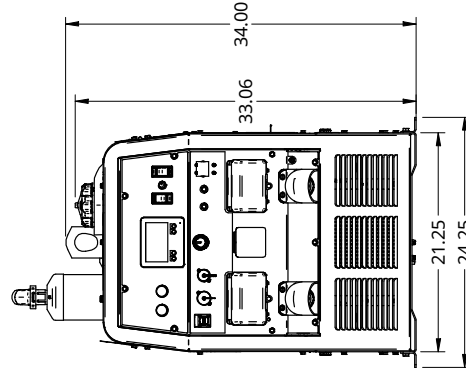
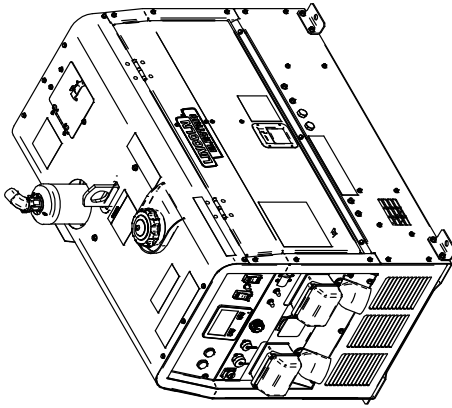

CUSTOMER ASSISTANCE POLICY

CUSTOMER ASSISTANCE POLICY

The business of Lincoln Electric is manufacturing and selling high quality welding equipment, automated welding systems, consumables, and cutting equipment. Our challenge is to meet the needs of our customers, who are experts in their fields, and to exceed their expectations. On occasion, purchasers may ask Lincoln Electric for information or technical information about their use of our products. Our employees respond to inquiries to the best of their ability based on information and specifications provided to them by the customers and the knowledge they may have concerning the application. Our employees, however, are not in a position to verify the information provided or to evaluate the engineering requirements for the particular weldment, or to provide engineering advice in relation to a specific situation or application. Accordingly, Lincoln Electric does not warrant or guarantee or assume any liability with respect to such information or communications. Moreover, the provision of such information or technical information does not create, expand, or alter any warranty on our products. Any express or implied warranty that might arise from the information or technical information, including any implied warranty of merchantability or any warranty of fitness for any customers' particular purpose or any other equivalent or similar warranty is specifically disclaimed.

Lincoln Electric is a responsive manufacturer, but the definition of specifications, and the selection and use of specific products sold by Lincoln Electric is solely within the control of, and remains the sole responsibility of the customer. Many variables beyond the control of Lincoln Electric affect the results obtained in applying these types of fabrication methods and service requirements.

WELD FUME CONTROL EQUIPMENT

The operation of welding fume control equipment is affected by various factors including proper use and positioning of the equipment, maintenance of the equipment and the specific welding procedure and application involved. Worker exposure level should be checked upon installation and periodically thereafter to be certain it is within applicable OSHA PEL and ACGIH TLV limits.

PARTS LIST

Content/Details may be changed or updated without notice. For most current Instruction Manuals, go to PARTS.LINCOLNELECTRIC.COM.

