

Operator's Manual

ELEVATE[®] SLi

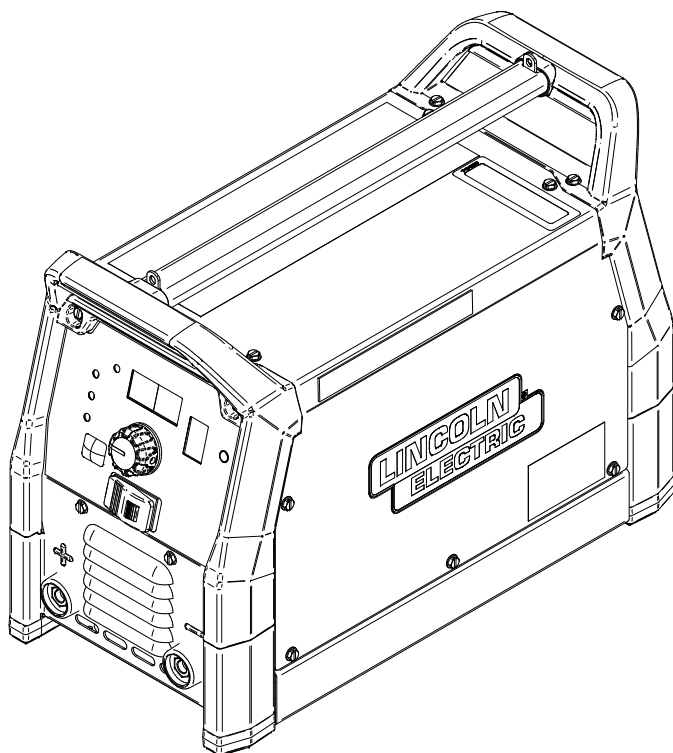

For use with machines having Code Numbers:

12935



Register your machine:

www.lincolnelectric.com/register

Authorized Service and Distributor Locator:

www.lincolnelectric.com/locator

Save for future reference

Date Purchased

Code: (ex: 10859)

Serial: (ex: U1060512345)

Need Help? Call 1.888.935.3877
to talk to a Service Representative

Hours of Operation:
8:00 AM to 6:00 PM (ET) Mon. thru Fri.

After hours?
Use "Ask the Experts" at lincolnelectric.com
A Lincoln Service Representative will contact you
no later than the following business day.

For Service outside the USA:
Email: globalservice@lincolnelectric.com

THANK YOU FOR SELECTING A QUALITY PRODUCT BY LINCOLN ELECTRIC.

PLEASE EXAMINE CARTON AND EQUIPMENT FOR DAMAGE IMMEDIATELY

When this equipment is shipped, title passes to the purchaser upon receipt by the carrier. Consequently, claims for material damaged in shipment must be made by the purchaser against the transportation company at the time the shipment is received.

SAFETY DEPENDS ON YOU

Lincoln arc welding and cutting equipment is designed and built with safety in mind. However, your overall safety can be increased by proper installation ... and thoughtful operation on your part. **DO NOT INSTALL, OPERATE OR REPAIR THIS EQUIPMENT WITHOUT READING THIS MANUAL AND THE SAFETY PRECAUTIONS CONTAINED THROUGHOUT.** And, most importantly, think before you act and be careful.



WARNING

This statement appears where the information must be followed exactly to avoid serious personal injury or loss of life.



CAUTION

This statement appears where the information must be followed to avoid minor personal injury or damage to this equipment.



KEEP YOUR HEAD OUT OF THE FUMES.

DON'T get too close to the arc. Use corrective lenses if necessary to stay a reasonable distance away from the arc.

READ and obey the Safety Data Sheet (SDS) and the warning label that appears on all containers of welding materials.

USE ENOUGH VENTILATION or exhaust at the arc, or both, to keep the fumes and gases from your breathing zone and the general area.

IN A LARGE ROOM OR OUTDOORS, natural ventilation may be adequate if you keep your head out of the fumes (See below).

USE NATURAL DRAFTS or fans to keep the fumes away from your face.

If you develop unusual symptoms, see your supervisor. Perhaps the welding atmosphere and ventilation system should be checked.

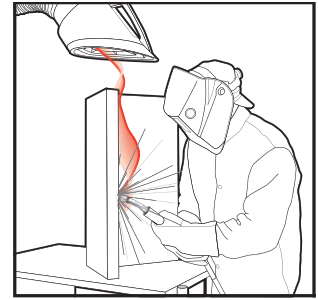

WEAR CORRECT EYE, EAR & BODY PROTECTION

PROTECT your eyes and face with welding helmet properly fitted and with proper grade of filter plate (See ANSI Z49.1).

PROTECT your body from welding spatter and arc flash with protective clothing including woolen clothing, flame-proof apron and gloves, leather leggings, and high boots.

PROTECT others from splatter, flash, and glare with protective screens or barriers.

IN SOME AREAS, protection from noise may be appropriate.

BE SURE protective equipment is in good condition.

Also, wear safety glasses in work area **AT ALL TIMES.**



SPECIAL SITUATIONS

DO NOT WELD OR CUT containers or materials which previously had been in contact with hazardous substances unless they are properly cleaned. This is extremely dangerous.

DO NOT WELD OR CUT painted or plated parts unless special precautions with ventilation have been taken. They can release highly toxic fumes or gases.

Additional precautionary measures

PROTECT compressed gas cylinders from excessive heat, mechanical shocks, and arcs; fasten cylinders so they cannot fall.

BE SURE cylinders are never grounded or part of an electrical circuit.

REMOVE all potential fire hazards from welding area.

ALWAYS HAVE FIRE FIGHTING EQUIPMENT READY FOR IMMEDIATE USE AND KNOW HOW TO USE IT.



SECTION A: WARNINGS



CALIFORNIA PROPOSITION 65 WARNINGS



WARNING: Breathing diesel engine exhaust exposes you to chemicals known to the State of California to cause cancer and birth defects, or other reproductive harm.

- Always start and operate the engine in a well-ventilated area.
- If in an exposed area, vent the exhaust to the outside.
- Do not modify or tamper with the exhaust system.
- Do not idle the engine except as necessary.

For more information go to www.P65warnings.ca.gov/diesel

WARNING: This product, when used for welding or cutting, produces fumes or gases which contain chemicals known to the State of California to cause birth defects and, in some cases, cancer. (California Health & Safety Code § 25249.5 *et seq.*)



WARNING: Cancer and Reproductive Harm
www.P65warnings.ca.gov

ARC WELDING CAN BE HAZARDOUS. PROTECT YOURSELF AND OTHERS FROM POSSIBLE SERIOUS INJURY OR DEATH. KEEP CHILDREN AWAY. PACEMAKER WEARERS SHOULD CONSULT WITH THEIR DOCTOR BEFORE OPERATING.

Read and understand the following safety highlights. For additional safety information, it is strongly recommended that you purchase a copy of "Safety in Welding & Cutting - ANSI Standard Z49.1" from the American Welding Society, P.O. Box 351040, Miami, Florida 33135 or CSA Standard W117.2. A Free copy of "Arc Welding Safety" booklet E205 is available from the Lincoln Electric Company, 22801 St. Clair Avenue, Cleveland, Ohio 44117-1199.

BE SURE THAT ALL INSTALLATION, OPERATION, MAINTENANCE AND REPAIR PROCEDURES ARE PERFORMED ONLY BY QUALIFIED INDIVIDUALS.



FOR ENGINE POWERED EQUIPMENT.

- 1.a. Turn the engine off before troubleshooting and maintenance work unless the maintenance work requires it to be running.



- 1.b. Do not add the fuel near an open flame welding arc or when the engine is running. Stop the engine and allow it to cool before refueling to prevent spilled fuel from vaporizing on contact with hot engine parts and igniting. Do not spill fuel when filling tank. If fuel is spilled, wipe it



up and do not start engine until fumes have been eliminated.

- 1.c. Keep all equipment safety guards, covers and devices in position and in good repair. Keep hands, hair, clothing and tools away from V-belts, gears, fans and all other moving parts when starting, operating or repairing equipment.
- 1.d. In some cases it may be necessary to remove safety guards to perform required maintenance. Remove guards only when necessary and replace them when the maintenance requiring their removal is complete. Always use the greatest care when working near moving parts.
- 1.e. Do not put your hands near the engine fan. Do not attempt to override the governor or idler by pushing on the throttle control rods while the engine is running.
- 1.f. To prevent accidentally starting gasoline engines while turning the engine or welding generator during maintenance work, disconnect the spark plug wires, distributor cap or magneto wire as appropriate.
- 1.g. To avoid scalding, do not remove the radiator pressure cap when the engine is hot.
- 1.h. Using a generator indoors CAN KILL YOU IN MINUTES.
- 1.i. Generator exhaust contains carbon monoxide. This is a poison you cannot see or smell.
- 1.j. NEVER use inside a home or garage, EVEN IF doors and windows are open.
- 1.k. Only use OUTSIDE and far away from windows, doors and vents.
- 1.l. Avoid other generator hazards. READ MANUAL BEFORE USE.



ELECTRIC AND MAGNETIC FIELDS MAY BE DANGEROUS



- 2.a. Electric current flowing through any conductor causes localized Electric and Magnetic Fields (EMF). Welding current creates EMF fields around welding cables and welding machines
- 2.b. EMF fields may interfere with some pacemakers, and welders having a pacemaker should consult their physician before welding.
- 2.c. Exposure to EMF fields in welding may have other health effects which are now not known.
- 2.d. All welders should use the following procedures in order to minimize exposure to EMF fields from the welding circuit:
- 2.d.1. Route the electrode and work cables together - Secure them with tape when possible.
- 2.d.2. Never coil the electrode lead around your body.
- 2.d.3. Do not place your body between the electrode and work cables. If the electrode cable is on your right side, the work cable should also be on your right side.
- 2.d.4. Connect the work cable to the workpiece as close as possible to the area being welded.
- 2.d.5. Do not work next to welding power source.



ELECTRIC SHOCK CAN KILL.



- 3.a. The electrode and work (or ground) circuits are electrically “hot” when the welder is on. Do not touch these “hot” parts with your bare skin or wet clothing. Wear dry, hole-free gloves to insulate hands.
- 3.b. Insulate yourself from work and ground using dry insulation. Make certain the insulation is large enough to cover your full area of physical contact with work and ground.

In addition to the normal safety precautions, if welding must be performed under electrically hazardous conditions (in damp locations or while wearing wet clothing; on metal structures such as floors, gratings or scaffolds; when in cramped positions such as sitting, kneeling or lying, if there is a high risk of unavoidable or accidental contact with the workpiece or ground) use the following equipment:

- Semiautomatic DC Constant Voltage (Wire) Welder.
 - DC Manual (Stick) Welder.
 - AC Welder with Reduced Voltage Control.
- 3.c. In semiautomatic or automatic wire welding, the electrode, electrode reel, welding head, nozzle or semiautomatic welding gun are also electrically “hot”.
 - 3.d. Always be sure the work cable makes a good electrical connection with the metal being welded. The connection should be as close as possible to the area being welded.
 - 3.e. Ground the work or metal to be welded to a good electrical (earth) ground.
 - 3.f. Maintain the electrode holder, work clamp, welding cable and welding machine in good, safe operating condition. Replace damaged insulation.
 - 3.g. Never dip the electrode in water for cooling.
 - 3.h. Never simultaneously touch electrically “hot” parts of electrode holders connected to two welders because voltage between the two can be the total of the open circuit voltage of both welders.
 - 3.i. When working above floor level, use a safety belt to protect yourself from a fall should you get a shock.
 - 3.j. Also see Items 6.c. and 8.



ARC RAYS CAN BURN.



- 4.a. Use a shield with the proper filter and cover plates to protect your eyes from sparks and the rays of the arc when welding or observing open arc welding. Headshield and filter lens should conform to ANSI Z87.1 standards.
- 4.b. Use suitable clothing made from durable flame-resistant material to protect your skin and that of your helpers from the arc rays.
- 4.c. Protect other nearby personnel with suitable, non-flammable screening and/or warn them not to watch the arc nor expose themselves to the arc rays or to hot spatter or metal.



FUMES AND GASES CAN BE DANGEROUS.



- 5.a. Welding may produce fumes and gases hazardous to health. Avoid breathing these fumes and gases. When welding, keep your head out of the fume. Use enough ventilation and/or exhaust at the arc to keep fumes and gases away from the breathing zone. **When welding hardfacing (see instructions on container or SDS) or on lead or cadmium plated steel and other metals or coatings which produce highly toxic fumes, keep exposure as low as possible and within applicable OSHA PEL and ACGIH TLV limits using local exhaust or mechanical ventilation unless exposure assessments indicate otherwise. In confined spaces or in some circumstances, outdoors, a respirator may also be required. Additional precautions are also required when welding on galvanized steel.**
- 5.b. The operation of welding fume control equipment is affected by various factors including proper use and positioning of the equipment, maintenance of the equipment and the specific welding procedure and application involved. Worker exposure level should be checked upon installation and periodically thereafter to be certain it is within applicable OSHA PEL and ACGIH TLV limits.
- 5.c. Do not weld in locations near chlorinated hydrocarbon vapors coming from degreasing, cleaning or spraying operations. The heat and rays of the arc can react with solvent vapors to form phosgene, a highly toxic gas, and other irritating products.
- 5.d. Shielding gases used for arc welding can displace air and cause injury or death. Always use enough ventilation, especially in confined areas, to insure breathing air is safe.
- 5.e. Read and understand the manufacturer’s instructions for this equipment and the consumables to be used, including the Safety Data Sheet (SDS) and follow your employer’s safety practices. SDS forms are available from your welding distributor or from the manufacturer.
- 5.f. Also see item 1.j.



WELDING AND CUTTING SPARKS CAN CAUSE FIRE OR EXPLOSION.

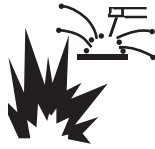

- 6.a. Remove fire hazards from the welding area. If this is not possible, cover them to prevent the welding sparks from starting a fire. Remember that welding sparks and hot materials from welding can easily go through small cracks and openings to adjacent areas. Avoid welding near hydraulic lines. Have a fire extinguisher readily available.
- 6.b. Where compressed gases are to be used at the job site, special precautions should be used to prevent hazardous situations. Refer to "Safety in Welding and Cutting" (ANSI Standard Z49.1) and the operating information for the equipment being used.
- 6.c. When not welding, make certain no part of the electrode circuit is touching the work or ground. Accidental contact can cause overheating and create a fire hazard.
- 6.d. Do not heat, cut or weld tanks, drums or containers until the proper steps have been taken to insure that such procedures will not cause flammable or toxic vapors from substances inside. They can cause an explosion even though they have been "cleaned". For information, purchase "Recommended Safe Practices for the Preparation for Welding and Cutting of Containers and Piping That Have Held Hazardous Substances", AWS F4.1 from the American Welding Society (see address above).
- 6.e. Vent hollow castings or containers before heating, cutting or welding. They may explode.
- 6.f. Sparks and spatter are thrown from the welding arc. Wear oil free protective garments such as leather gloves, heavy shirt, cuffless trousers, high shoes and a cap over your hair. Wear ear plugs when welding out of position or in confined places. Always wear safety glasses with side shields when in a welding area.
- 6.g. Connect the work cable to the work as close to the welding area as practical. Work cables connected to the building framework or other locations away from the welding area increase the possibility of the welding current passing through lifting chains, crane cables or other alternate circuits. This can create fire hazards or overheat lifting chains or cables until they fail.
- 6.h. Also see item 1.b.
- 6.i. Read and follow NFPA 51B "Standard for Fire Prevention During Welding, Cutting and Other Hot Work", available from NFPA, 1 Batterymarch Park, PO box 9101, Quincy, MA 022690-9101.
- 6.j. Do not use a welding power source for pipe thawing.



CYLINDER MAY EXPLODE IF DAMAGED.



- 7.a. Use only compressed gas cylinders containing the correct shielding gas for the process used and properly operating regulators designed for the gas and pressure used. All hoses, fittings, etc. should be suitable for the application and maintained in good condition.
- 7.b. Always keep cylinders in an upright position securely chained to an undercarriage or fixed support.
- 7.c. Cylinders should be located:
 - Away from areas where they may be struck or subjected to physical damage.
 - A safe distance from arc welding or cutting operations and any other source of heat, sparks, or flame.
- 7.d. Never allow the electrode, electrode holder or any other electrically "hot" parts to touch a cylinder.
- 7.e. Keep your head and face away from the cylinder valve outlet when opening the cylinder valve.
- 7.f. Valve protection caps should always be in place and hand tight except when the cylinder is in use or connected for use.
- 7.g. Read and follow the instructions on compressed gas cylinders, associated equipment, and CGA publication P-1, "Precautions for Safe Handling of Compressed Gases in Cylinders," available from the Compressed Gas Association, 14501 George Carter Way Chantilly, VA 20151.



FOR ELECTRICALLY POWERED EQUIPMENT.



- 8.a. Turn off input power using the disconnect switch at the fuse box before working on the equipment.
- 8.b. Install equipment in accordance with the U.S. National Electrical Code, all local codes and the manufacturer's recommendations.
- 8.c. Ground the equipment in accordance with the U.S. National Electrical Code and the manufacturer's recommendations.

Refer to
<http://www.lincolnelectric.com/safety>
for additional safety information.



FOR BATTERY VOLTAGE CLASS B ELECTRIC POWER SOURCES



- 9.a. Recharge only with the charger specified by the manufacturer. A charger that is suitable for one type of battery pack can create a risk of fire when used with another battery pack.
- 9.b. Use welding power sources only with specifically designated battery packs. Use of any other battery packs can create a risk of injury and fire.
- 9.c. When battery pack is not in use, keep it away from other metal objects, like paper clips, coins, keys, nails, screws or other small metal objects that can make a connection from one terminal to another. Shorting the battery terminals together can cause burns or a fire.
- 9.d. Under abusive conditions, liquid can be ejected from the battery; avoid contact. If contact accidentally occurs, flush with water. If liquid contacts eyes, additionally seek medical help. Liquid ejected from the battery can cause irritation or burns.
- 9.e. Do not use a battery pack or welding power source that is damaged or modified. Damaged or modified batteries can exhibit unpredictable behavior resulting in fire, explosion, or risk of injury.
- 9.f. Do not expose a battery pack or welding power source to excessive temperature. Exposure to fire or temperature above 130°C (265°F) can cause explosion
- 9.g Follow all charging instructions and do not charge the battery pack or welding power source outside the temperature range specified in the instructions. Charging improperly or at temperatures outside the specified range can damage the battery and increase the risk of fire.

Refer to
<http://www.lincolnelectric.com/safety>
for additional safety information.

INSTALLATIONSECTION A

TECHNICAL SPECIFICATIONSA-1

INPUT AND GROUND CONNECTIONSA-1

LOCATION AND VENTILATIONA-2

ENVIRONMENTAL RATINGA-2

WELDING CABLE RECOMMENDATIONA-2

BATTERY INFORMATIONA-3

PERMISSIBLE OPERATING RANGE AND STORAGEA-3

CHARGINGA-3

CHARGING CIRCUIT PROTECTIONA-3

CHARGING TEMPERATURE LIMITATIONSA-3

CHARGING WHILE WELDINGA-3

AUTO-SHUTDOWNA-3

CHARGING FROM AN ENGINE DRIVEN GENERATORA-4

CHARGING FROM AN INVERTERA-4

OPERATIONSECTION B

CASE FRONT CONTROLSB-1

CASE BACK CONTROLB-2

STICK WELDINGB-3

TIG WELDINGB-3

SELECTING WELD MODESB-4

ADVANCED MENU FEATURESB-5

ACCESSORIESSECTION C

INCLUDED ACCESSORIESC-1

OPTIONAL ACCESSORIESC-1

MAINTENANCESECTION D

ROUTINE MAINTENANCED-1

NAMEPLATES / WARNING DECALS MAINTENANCED-2

TROUBLESHOOTING.....SECTION E





















DIAGRAMSSECTION F

Parts Listparts.lincolnelectric.com

Content/details may be changed or updated without notice.
 For most current Instruction Manuals, go to parts.lincolnelectric.com.

GRAPHIC SYMBOLS

The following symbols are shown on the machine or within the manual:

I	ON		UNIVERSAL WASTE
O	OFF		DO NOT DISCARD IN FIRE
	SMAW (STICK)		WARNING OR CAUTION
	WELDING GTAW (TIG)		INSTRUCTION MANUAL
	WELDING TOGGLE		SHOCK HAZARD
A	WELDING AMPERAGE		EXPLOSION
	HIGH TEMPERATURE		ARC RAYS
	CHARGING		FUMES AND GASES
	CHARGING COMPLETE		MOVING PARTS
	INPUT CHARGING CORD		
+	POSTIVE OUTPUT		
-	NEGATIVE OUTPUT		
	CIRCUIT BREAKER		
U ₀	OPEN CIRCUIT VOLTAGE		
U ₂	OUTPUT VOLTAGE		
I ₂	OUTPUT AMPERAGE		
	DIRECT CURRENT		
	INPUT POWER		
1 ~	SINGLE PHASE		
U ₁	INPUT VOLTAGE		
I ₁	INPUT CURRENT		
U _b	BATTERY VOLTAGE		
I _b	BATTERY INPUT CURRENT		
E	BATTERY CAPACITY		
	DANERGOUS VOLTAGE		
	RECYCLE		



GENERAL DESCRIPTION

The Lincoln Electric Elevate® SLi Battery Welder combines an extremely portable design with premium arc performance to create a leading option for remote welding jobs.

With a total weight of 33 lbs (15 kg), the Elevate® SLi is light enough to take anywhere and carries easily with a supplied shoulder strap and ergonomic mounting locations. An additional rolling case can be purchased for ultimate transport needs. Featuring Stick (SMAW) and TIG (GTAW) welding capabilities at a max output of 145A, the machine is an excellent option for “grab-and-go” maintenance and repair jobs.

The Elevate® SLi utilizes a lithium iron phosphate (LFP) chemistry to provide increased safety, longer battery lifetime, and an environmentally friendly option. Plus, the fully integrated lithium-ion battery allows for a simple all-in-one charging system utilizing a common 120V power cord.

Included Accessories:

- 1: K5612-1 Industrial Electrode Holder and Cable
- 2: K5482-1 Heavy Duty Work Clamp and Cable
- 3: KP5655-1 120V Charging Cord
- 4: KP5656-1 Adjustable Carrying Strap

DESIGN FEATURES

- Chopper® Technology – Facilitate optimal output control of current and voltage.
- 120V input voltage and standard charge cable for easy simplified charging.
- Ultimate Portability – The 33 lb. machine features handles and carrying strap. Add a rolling case for maximum mobility.
- Compact, Durable Case – IP23S enclosure rating ensures the machine will withstand the intended welding environments.
- Fan-as-Needed permits increasing and decreasing air-flow through the machine to ensure proper cooling as needed.
- Wide output range to allow for a wide variety of electrodes to be used - Up to 5/32" (4.0 mm).
- Uses 10-25 Twist Mate™ connectors for the electrode holder and work clamp.

INSTALLATION

TECHNICAL SPECIFICATIONS

ELEVATE™ SLi BATTERY WELDER								
Product Number	Input Power	Rated Output @ 104°F (40°C)	Output Range	Dimensions H x W x L in (mm)	Weight lbs (kg)	Open Circuit Voltage	Battery Energy (Wh)	Battery Chemistry
K4706-1	120V / 1 ~ / 60Hz	STICK: 145A /25.8V TIG: 145A /15.8V	STICK: 10-145A TIG: 4-145A	14.0 x 9.1 x 18.3 (356 x 231 x 465)	33 (15)	Average: 55 VDC Peak: 72 VDC	576	Lithium Iron Phosphate (LFP)

AGENCY APPROVALS & STANDARDS

CONFORMITY MARK	CSA
INGRESS PROTECTION RATING	IP23S
IEC STANDARD	60974-1

The Elevate® SLi battery-powered welder contains a fully regulated lithium-ion battery as classified by UN3481.

All US Department of Transportation regulations regarding the shipment of lithium-ion batteries must be followed.

SAFETY PRECAUTIONS

DO NOT attempt to use this equipment until you have thoroughly read all operating and maintenance manuals supplied with your equipment.

Only qualified personnel should install, use, or service this equipment.

WARNING

ELECTRIC SHOCK can kill.

- Do not touch electrically live parts such as output terminals or internal wiring.
- Insulate yourself from the work and ground.
- Always wear dry insulating gloves.



INPUT AND GROUND CONNECTIONS

The Elevate® SLi should be charged from a properly grounded 120V AC power source that is protected with a minimum breaker of 15A. Only use the supplied power cord to charge the machine and DO NOT modify the power cord. If the cord is damaged, a new one can be ordered - See ACCESSORIES section for part number.

The Elevate® SLi should only be serviced by a qualified service technician at a Lincoln Electric service location. DO NOT attempt to troubleshoot or service by removing the machine case sides. DO NOT attempt to troubleshoot or service lithium ion battery. Failure to comply may result in bodily injury or death.

LOCATION AND VENTILATION

The welder should be located on a secure, level surface, or recommended undercarriage. If not placed correctly, the machine may topple over.

To minimize overheating, place the machine in a dry location, provide an unrestricted flow of clean, cool air to the cooling inlets, and avoid restricting the cooling outlets. Air will move from the back of the machine through the front cooling outlets.



WARNING

DO NOT MOUNT OR PLACE OVER COMBUSTIBLE SURFACES.

Dirt and dust that can be drawn into the welding machine should be kept to a minimum. Failure to observe these precautions can result in excessive operating temperatures, nuisance thermal trips, and potential failures.

The Elevate® SLi is not suitable for stacking.

ENVIRONMENTAL RATING

This machine is IP23S rated for use in an outdoor environment. The machine should not be subjected to falling water during use nor should any parts of it be submerged in water. Doing so may cause improper operation as well as pose a safety hazard. The best practice is to keep the machine in a dry, sheltered area.

Read and follow the Electric Shock Warnings in the safety section if welding must be performed under electrically hazardous conditions such as welding in wet areas or water on the work piece.

WELDING CABLE RECOMMENDATION

Best to keep a short cable length and use the provided 4 AWG weld cables for the purpose of minimizing cable voltage drop.

These connections should be checked periodically and tightened if necessary.

BATTERY INFORMATION

The Elevate® SLI contains a 576 Wh lithium iron phosphate rechargeable battery that can provide 1000 cycles or more of service with the proper care. A fully charged battery will provide between 4 to 145 amps of welding output depending on the selected weld process.

To maximize battery life and protect the battery from damage, store, charge, and use the machine in the optimum operating ranges listed below:

- Optimum Use, Charging, and Storage Temp: 15°C to 25°C (59°F to 77°F) and 50% humidity

Machine run time will vary due to factors such as, but not limited to, welding conditions, electrode type/size, machine parameters, material properties, operator technique, and/or age of the battery.

The typical time to fully charge a dead battery in Optimum Use conditions is approximately 60 minutes. Charging time may vary up to approximately 2 hours based on limitation outlined in the CHARGING TEMPERATURE LIMITATIONS. A full charge is considered at charge level of 95% or higher.

PERMISSIBLE OPERATING RANGE AND STORAGE

The machine can be used within min/max permissible temp ranges as listed below:

- Permissible Charging Environment Temp: 5°C to 40°C (41°F to 104°F)
- Max/Min Operating Temp: -10°C to 40°C (14°F to 104°F)
- Permissible Storage Temp: -10°C to 45°C (14°F to 113°F)

Store the machine with at least 75% of battery life left and avoid storing the machine with a fully discharged battery. The battery will retain charge in storage, but should be fully recharged every six months to prevent permanent battery damage.

It is permissible to leave the unit plugged in to retain charge, but not required. Storing the welder with a high charge above 75% is recommended. When the unit is removed from storage, top off the charge before use.

CHARGING

The Elevate® SLI is designed with an integrated charger that is contained completely within the machine. To charge, plug the supplied charging cord into the back of the machine, then plug into a standard 120V AC outlet. Only the charging cord supplied with the welder can be used, DO NOT use any other charging cord.

Once plugged in, the front panel charging LED will blink while the unit is charging. When charging is complete, the LED will light up solid and cease blinking.

Upon initial receipt, it is recommended to fully charge the battery and leave it plugged in to condition the battery before initial use. For optimal battery life, leave the unit plugged in overnight once a month to complete a full battery balance cycle.

CHARGING CIRCUIT PROTECTION

The Elevate® SLI is designed with charging circuit protection to protect the machine from excess current draw. The re-settable circuit breaker is located next to the charging cord receptacle on the back of the machine, and will trip at 10A of current. If the circuit breaker trips, it can be reset by first unplugging the machine from the wall, and then pushing the circuit breaker button. A constantly tripping breaker is indicative of a problem with either supply power or the machine itself. If tripping continues, see TROUBLESHOOTING section.

CHARGING TEMPERATURE LIMITATIONS

To protect the battery from damage, the machine is programmed to charge when the battery is within the charging temperatures of 5°C to 45°C (41°F to 113°F). If it is any colder than this, the machine must be brought to a warmer location and let it come up to temperature before charging will begin. If it is hotter than this, then the battery must rest until the temperature comes down, or the machine must be brought into a cooler environment for charging.

Charging will be restricted or reduced in extreme environments. See the TROUBLESHOOTING section for LED blink codes regarding charging faults.

Welding with the machine at a high duty cycle and high ambient temperature in some instances may be enough to bring the battery temperature past the charging limit. In this case, let the machine cool down while it is on, so the fan can cool the machine down to charging temperatures before recharging.

CHARGING WHILE WELDING

Welding can be performed when the Elevate® SLI is plugged in and charging. When an arc is struck the machine will sense the weld current and cease charging while the weld is performed. After welding the machine will switch back over to charge after 30 seconds.

It is possible to still drain the battery while the machine is charging while welding intermittently in this scenario. Welding will consume battery life faster than it can be replenished by the charger. It is also possible to bring the battery temperature above the charging temperature limit in this scenario. If this happens the machine must cool down using the internal fan until charging will begin again.

AUTO-SHUTDOWN

To conserve battery, the machine will auto-shutdown after 15 minutes of no welding activity when not plugged in. The machine will be need to be restarted by cycling the power switch.

If the unit is plugged into the wall, the auto-shutdown feature will be disabled. The power switch will be required to be turned OFF to shutdown the machine.

CHARGING FROM AN ENGINE DRIVEN GENERATOR

The machine is designed to operate on engine driven generators as long as the generator can supply adequate voltage, frequency, and power as indicated in the INSTALLATION section of this manual. The auxiliary supply of the generator must also meet the following conditions:

Frequency: 60 Hz

RMS voltage of the AC waveform: 90-140 V - Out of this range will trigger undervoltage and overvoltage protections.

Generator Minimum: 1800 Watts

It is important to check these conditions because many engine driven generators produce high voltage spikes. Operation of this machine with engine driven generators not conforming to these conditions is NOT RECOMMENDED. Damage may occur to the battery and will NOT be covered under warranty.

CHARGING FROM AN INVERTER

This machine can be charged from a vehicle on board or auxiliary power inverter only under the following conditions. It is important to note that by not following these guidelines damage may occur to the battery and will NOT be covered under warranty.

Inverter Minimum: 1200 Watts

Frequency: 60 Hz

RMS voltage of the AC waveform: 90-140V - Out of this range will trigger under and overvoltage protections.

LIMITED WELD OUTPUT AT EXTREME TEMPERATURES

To protect the battery from irreversible damage at extreme low and high temperatures, the weld output will be limited based off the battery temperature.

At **very low temperatures**, the output will be reduced. By welding, the battery temperature will increase to allow the machine to reach full output. At extreme low temperatures, the output will be disabled and E036 will display on the screen. It will be necessary to bring to a warmer environment to bring the temperature up.

At **very high temperatures**, the output will be disabled while E036 is displayed on the screen. This can occur if the machine becomes too hot from sustained high duty cycle use, or if the storage environment was too hot. It is recommended to leave the machine on when E036 is displayed, so the cooling fan can continue to run and cool down the machine. At extreme high temperatures the unit will protect itself by remaining off until it cools down. In this scenario, bring the machine to a cooler place, and allow to cool appropriately.

ESTIMATED ELECTRODE CONSUMPTION / WELD TIME

Table A.1 provides an estimated electrode consumption for common welding electrodes and weld time for Touch Start® TIG.

Actual results may vary due to factors such as, but not limited to:

- Welding Conditions
- Machine Parameters
- Material Properties
- Operator Technique
- Battery Lifecycle

TABLE A.1 ESTIMATED ELECTRODE CONSUMPTION / WELD TIME

ELECTRODE CONSUMPTION - STICK WELDING (SMAW)

	E6010		E6013		E7018	
	Electrodes Consumed	Amperage Setting	Electrodes Consumed	Amperage Setting	Electrodes Consumed	Amperage Setting
3/32 x 12 in (2.4 x 300 mm)**	20 - 22	60	16 - 18	75	11 - 13**	90
1/8 x 14 in (3.2 x 350 mm)	8 - 10	90	8 - 10	110	7 - 9	120
5/32 x 14 in (4.0 x 350 mm)	6 - 7	120	5 - 6	140	5 - 6	140

** 3/32 x 14 in (2.4 x 350mm)

TOUCH START TIG WELDING (GTAW)

	Total Arc Time to Battery Depletion (min)	Amps
1/16 in	20-22	100

CASE FRONT CONTROL

1: LOCKING POWER SWITCH

Controls turning the machine ON or OFF. The switch with lock in the OFF position when pushed from ON to OFF. To unlock, slide the red tab to the left and push switch in.

2: POSITIVE (+) AND NEGATIVE RECEPTACLES (-)

Easy twist lock connection of electrode holder and ground clamp. The sheet metal is embossed with positive and negative designations.

3: CONTROL KNOB

Select amperage setting or scroll through the advanced menu.

4: SEGMENTED DISPLAY

Reads welding amperage or advanced menu options.

5: PROCESS MODE BUTTON

Select between STICK, 6010 STICK, or TouchStart® TIG

6: WELD MODE LEDS

LED will light up when corresponding weld mode is active.

7: CHARGING INDICATOR

Illuminates to indicate the current charging status of the machine. When charging the LED will blink, and when fully charged the LED will remain solid. See TROUBLESHOOTING for all fault codes.

8: BATTERY CHARGE STATUS

Shows the current level of charge of the machine.

9: COOLING FAN EXHAUST

Cooling air exits out the case front louvers.

10: TEMPERATURE FAULT INDICATOR

Indicates the machine has reached an over temperature condition. If the light appears during machine use, the output will be temporarily suspended until the machine cools off to acceptable temperatures. DO NOT turn machine off, allow the machine to cool using the on board cooling fan.

11: FRONT STRAP ATTACHMENT

Carry strap attachment point at the top of the handle.

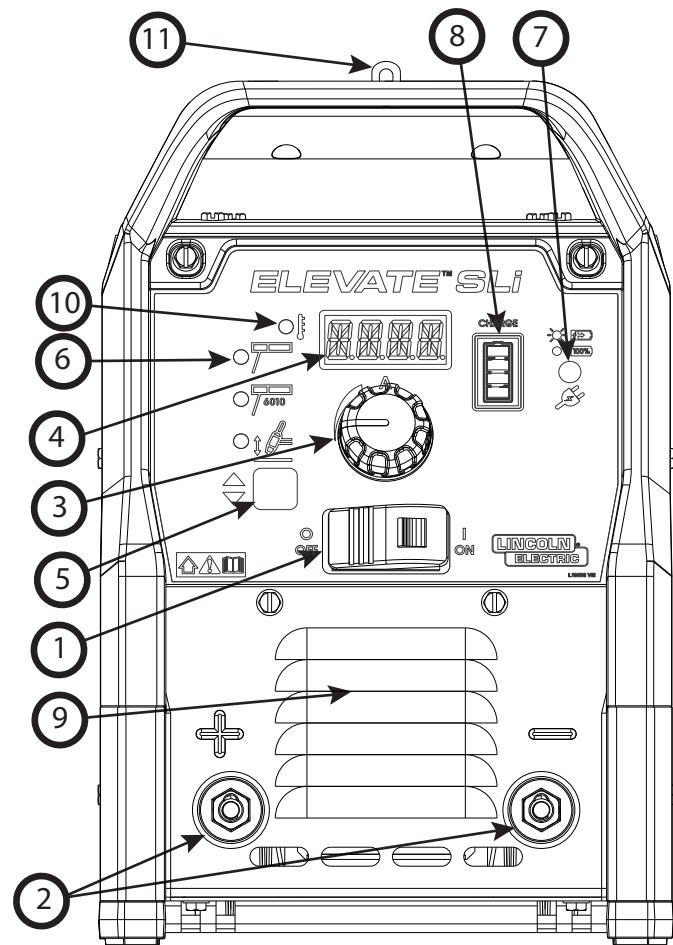

CASE BACK CONTROL**1: RATING PLATE INFORMATION**

Contains technical ratings, IP ratings, and certification body ratings.

2: CHARGING OVERCURRENT BREAKER

A 10A breaker to protect the 120V charging receptacle.

3: CHARGING RECEPTACLE

Low profile 120VAC receptacle used to charge the machine.

4: COOLING INLETS

Fresh air is pulled through the louvers on the case back and passed over internal components for efficient cooling.

5: REAR STRAP ATTACHMENT

Carry strap attachment at the top of the handle.

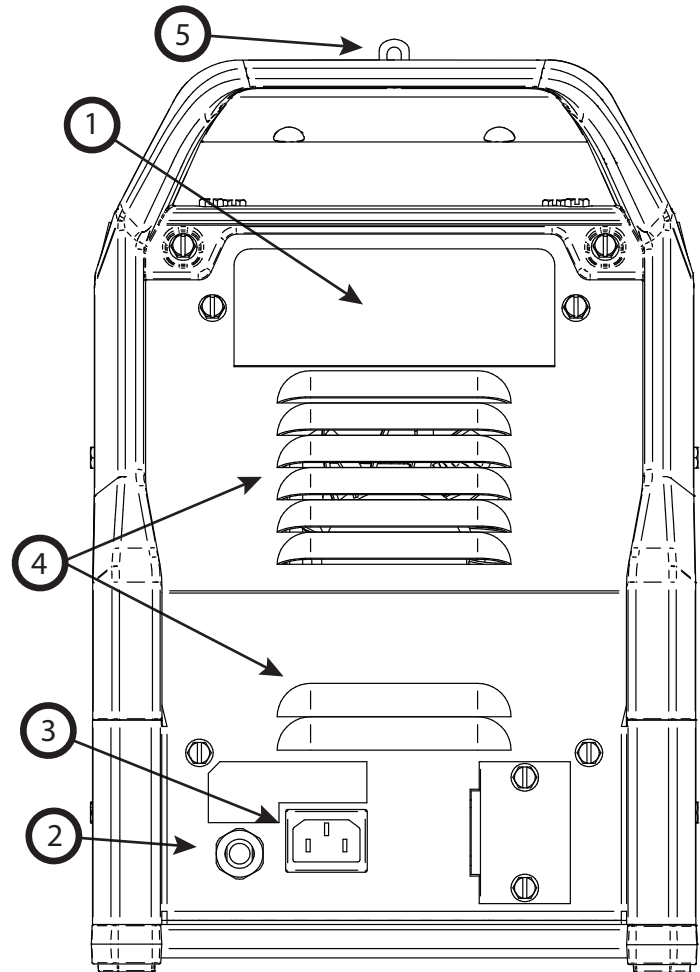

STICK WELDING

First determine the proper electrode polarity for the electrode to be used. Consult the electrode data for this information. Then connect the output cables to the output terminals of the machine for the selected polarity. Shown here is the connection method for DC(+) welding. (See Figure B.1)

Connect the welding cable to the (+) terminal and the work clamp to the (-) terminal. Insert the connector with the key lining up with the keyway and rotate approximately 1/4 turn clockwise. DO NOT over tighten.

To run DC(-) polarity, connect the welding cable to the (-) terminal and the work clamp to the (+) terminal.

TIG WELDING

The Elevate® SLi permits DC only TIG welding utilizing Touch Start®. TIG welding should be connected with the torch in the (-) terminal, and the work clamp in the (+) connector. See the ACCESSORIES section for the proper TIG torch selection. The TIG torch specified for the Elevate® SLi directly connects to the shielding gas bottle at the machine connector lug. There is no gas solenoid in the system, and gas must be turned on and off manually utilizing a gas control knob on the TIG torch. Additionally there is no connector available for a foot pedal, and amperage is not adjustable while welding. (See Figure B.2)

FIGURE B.1

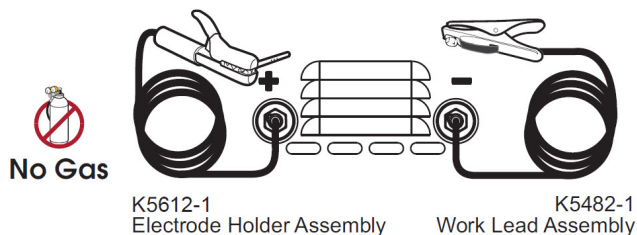

NOTE: DC- POLARITY MAY BE USED FOR THIN MATERIALS

FIGURE B.2

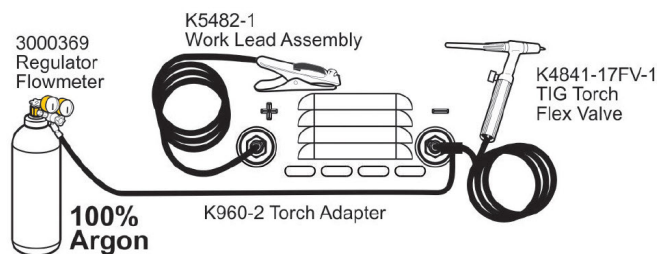

SELECTING WELD MODES

To switch between all welding modes, press the PROCESS MODE button underneath the welding modes on the front of the machine. Pressing this button will cycle through each mode, illuminating the LED light next to the mode you have selected.

1. STICK MODE

Select STICK mode when using 7018 series of electrodes. STICK mode will provide a softer arc compared to the 6010 STICK mode. The STICK mode can be used successfully with a large variety of electrodes.

2. 6010 STICK MODE

Use 6010 STICK mode for optimized 6010 welding performance when using this electrode series. Use this mode and electrode for deep roots or extra penetration when needed.

3. TOUCHSTART® TIG MODE

Select the TouchStart® TIG weld mode for DC TIG welding. To start, touch the workpiece. Gentle rock then lift the the torch to initiate the arc. See the ACCESSORIES section of the manual for proper TIG accessories.

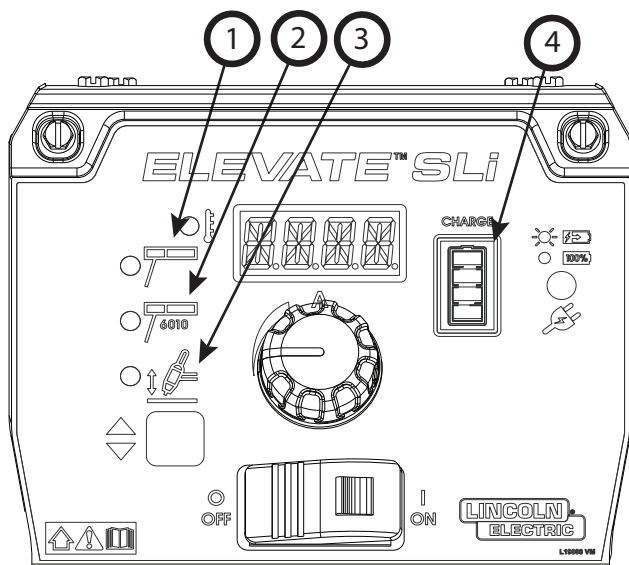

BATTERY CHARGE STATUS

4. STATE OF CHARGE

An estimated value of the state of charge (SOC) or charge level of the battery is indicated by the segmented display. At a full charge, the entire icon will be illuminated. As SOC varies by discharging and charging the battery, the segmented display will reflect the estimated charge remaining.

To recalibrate the Battery Charge Status, fully discharge and fully recharge the battery overnight to allow the the battery to balance.

ADVANCED MENU FEATURES

The machine is equipped with advanced stick features that can be accessed by holding the PROCESS MODE button down until the Advanced Menu appears on the display.

Press and hold PROCESS MODE button until ARCF appears, and use the CONTROL KNOB to scroll through the options. To adjust or activate a feature, scroll to the feature and then press the PROCESS MODE button. Use the CONTROL KNOB again to adjust feature parameters or turn the feature on or off. To exit the Advanced Menu you can scroll to exit, or let the machine sit 5-10 seconds without adjusting anything and it will return to the home screen. The advanced menu features are shown below.

Display Name	Feature
ARCF	ARC FORCE (STICK 0-10)
HOTS	HOT START (STICK/TIG 0-10)
PIPE	PIPE MODE (STICK ON/OFF)
CYCL	BATTERY CYCLE COUNT
SW	SOFTWARE VERSION
EXIT	EXITS THE MENU

Arc Force

Used to prevent the electrode from sticking during welding. It provides a temporary increase in current when the arc length becomes very short. Increasing the value from -10 (Soft) to +10 (Crisp) increases the short circuit current and prevents sticking of the electrode to the plate while welding, while decreasing the value reduces the amount of spatter.

Hot Start

Provides a temporary increase of the output current during the start of a weld. This helps ignite the arc quickly and reliably, preventing the electrode from sticking. The setting can be adjusted from 0 (Off) to +10. The higher the value the greater the output current during arc strike.

Pipe Mode

The machine also offers a pre-programmed Pipe Mode design specifically for downhill pipe welding application to provide superior welding performance for cellulosic and low-hydrogen stick electrodes. This mode optimizes arc performance to perform repairs and fabrication in piping systems. Once the Pipe Mode is selected and activated from the Advanced Menu, the 6010 LED will blink signifying Pipe Mode. To exit pipe mode, access the advanced feature menu and select OFF. The LED will stop blinking signifying Pipe mode is now off.

Battery Cycle Count

Shows the total number of battery cycles completed by the machine. The value is calculate based off the estimated average capacity over the life of the battery.

Software Version

Displays the current software version installed on the machine.

ACCESSORIES

INCLUDED ACCESSORIES

The machine comes with the accessories listed below:

200 Amp Industrial Electrode Holder and Cable

Includes twist mate (Dinse 10-25) connector, electrode holder, 12.5 ft. (3.8 m) 4 AWG cable.

Order: K5612-1

Heavy Duty Work Clamp and Cable

Includes twist mate (Dinse 10-25) connector, ground clamp, 12.5 ft. (3.8 m) 4 AWG cable.

Order: K5482-1

120V Charging Cord

Required power cord to charge the Elevate® SLi whenever the battery is depleted. This cord is suitable only for the Elevate® SLi Battery Welder.

Order: KP5655-1

Adjustable Carrying Strap

Adjustable shoulder strap only for use with the Elevate® SLi Battery Welder.

Order: KP5656-1

OPTIONAL ACCESSORIES

The following accessories can be ordered optionally:

Rolling Machine Case

This water-resistant, lockable case has enough space to store the Elevate® SLi Battery Welder and all of the accessories.

Order: K5548-1

Small Canvas Cover

Protect your Elevate® SLi Battery Welder. when not in use- made from red canvas that is flame retardant, mildew resistant and water repellent.

Order K2377-1

Canvas Accessory Bag

A canvas bag is available to store your welding accessories, with a convenient carrying handle and snaps to attach to the Elevate® SLi Battery Welder.

Order K3071-1

Caliber 17 Series TIG Torch-Flex/Valve 12.5FT

Premium Caliber® TIG Torch with a Flexible/Valve Torch Head and a 150A 60% Duty Cycle.

Order: K4841-17FV-1

Small Twist Mate™ Torch Adapter (with separate gas)

For connection of PTA-9V or PTA-17V torches (1-piece cable) to power sources without gas passing through the Twist Mate™ connection.

Order: K960-2

Caliber 17/18/26 Series TIG Torch Expendables Kit - 1/16"-1/8"

This includes all front-end parts needed to run a gas lens setup on the 17/18/26 Series TIG Torches.

Order: KP4760-HD

MAINTENANCE

⚠ WARNING



Before carrying out service, maintenance and/or repair jobs, fully disconnect power to the machine.



Use Personal Protective Equipment (PPE), including safety glasses, dust mask and gloves to avoid injury. This also applies to persons who enter the work area.



MOVING PARTS can injure.

- Do not operate with doors open or guards off
- Stop engine before servicing
- Keep away from moving parts



Have qualified personnel do all maintenance and troubleshooting work.

ROUTINE MAINTENANCE

If the Elevate® SLi will be in storage for longer than six months, ensure that the battery is at least 75% before entering storage. After six months, remove the welder from storage and recharge. Repeat this process every six months if machine will sit for long periods of time.

When the product is in regular use, it is recommended to leave the unit plugged in for an extended period of time to allow the battery to complete a full balance cycle. It is best practice to leave the unit plugged in overnight once every month.

The Elevate® SLi should be kept in a clean environment. If the machine becomes dusty and dirty, you can use compressed air to blow off the exterior case. Avoid using compressed air on the machine display and the louvers of the machine. It is possible to damage the equipment in this way. If the machine becomes wet for any reason, turn the machine off, allow the machine to dry in a an area with free airflow for 24 hours. DO NOT use the machine where it will be subject to water intrusion due to falling rain or splashing water.

The Elevate® SLi does not need any internal maintenance. Any internal maintenance should under no circumstance be attempted to be performed by a non-Lincoln Electric qualified service shop. If the need arises that the product needs maintenance or service work, please contact Lincoln Electric by going to www.lincolnelectric.com, or calling customer service at 1-888-935-3877.

Frequently check that the power cord is in good shape, with no cuts or damage to insulation. If power cord is damaged, it can be replaced by ordering a new one which can be found in the ACCESSORIES section of this manual. Keep the charger receptacle on the machine back clean and free of debris. If the charging receptacle becomes dirty, gently blow out with compressed air.

NAMEPLATES / WARNING DECALS MAINTENANCE

Whenever routine maintenance is performed on this machine - or at least yearly - inspect all nameplates and labels for legibility. Replace those which are no longer clear. Refer to the parts list for the replacement item number.

TROUBLESHOOTING

How to Use Troubleshooting Guide

WARNING

Service and Repair should only be performed by Lincoln Electric Factory Trained Personnel. Unauthorized repairs performed on this equipment may result in danger to the technician and machine operator and will invalidate your factory warranty. For your safety and to avoid Electrical Shock, please observe all safety notes and precautions detailed throughout this manual.



This Troubleshooting Guide is provided to help you locate and repair possible machine malfunctions. Simply follow the three-step procedure listed below.

Step 1. LOCATE PROBLEM (SYMPTOM).

Look under the column labeled “PROBLEM (SYMPTOMS)”. This column describes possible symptoms that the machine may exhibit. Find the listing that best describes the symptom that the machine is exhibiting.

Step 2. POSSIBLE CAUSE.

The second column labeled “POSSIBLE CAUSE” lists the obvious external possibilities that may contribute to the machine symptom.

Step 3. RECOMMENDED COURSE OF ACTION

This column provides a course of action for the Possible Cause, generally it states to contact your local Lincoln Authorized Field Service Facility.

If you do not understand or are unable to perform the Recommended Course of Action safely, contact your local Lincoln Authorized Field Service Facility.

Observe all additional Safety Guidelines detailed throughout this manual.

FAULT CODES FOR CHARGING LED INDICATOR

FAULT	BLINK CODE	RESOLUTION
Normal Charging	1 Constant Blink	N/A - Normal Operation
Full Charge (>95%)	Steady LED	N/A - Normal Operation
Low Temperature Fault	2 Blinks - Pause - 2 Blinks	Bring unit into a warmer environment and allow to reach 5°C (41°F)
High Temperature Fault	3 Blinks - Pause - 3 Blinks	Bring unit into a cooler environment and allow to reach 45°C (113°F)

ERROR CODES FOR DISPLAY

FAULT	BLINK CODE	RESOLUTION
High Battery Temperature	E036	Allow unit to remain on while fan runs and/or bring to cooler environment and allow unit to cool.
Low Battery Temperature	E036	Bring unit to warmer environment and allow to warm.



If for any reason you do not understand the test procedures or are unable to perform the tests/repairs safely, contact your Lincoln Authorized Service Facility for technical troubleshooting assistance before you proceed.

WWW.LINCOLNELECTRIC.COM/LOCATOR

Observe all Safety Guidelines detailed throughout this manual

PROBLEM (SYMPTOMS)	POSSIBLE AREAS OF MISADJUSTMENT(S)	RECOMMENDED COURSE OF ACTION
Machine will not turn on.	<p>1: Check that the battery does not need recharged by plugging the machine in. Ensure charging light comes on and is blinking to signify charging is taking place.</p> <p>2: Make certain the power switch is in the ON position.</p> <p>3: Make certain the machine is not in sleep mode. Cycle power by turning the power switch OFF then back ON.</p> <p>4: Ensure machine is within operating limits (see Permissible Operating Range and Storage).</p>	<p>If all recommended possible areas of misadjustment have been checked and the problem persists, Contact your local Lincoln Authorized Field Service Facility.</p>
Machine will not charge the battery.	<p>1: Ensure the power cord is plugged in to a reliable power source, and the power cord is not damaged.</p> <p>2: Make certain the 10A push button circuit breaker on the back of the machine is not tripped. Push the button on the circuit breaker to reset it.</p> <p>3: Ensure machine is within charging temperature limits (see Charging Temperature Limitations in manual).</p>	
Unstable Arc or Poor Welding Performance	<p>1: Ensure that the welding leads are tightly connected to the machine.</p> <p>2: Ensure the workpiece is properly grounded with a good connection.</p> <p>3: Check Advanced Menu Features options for welding parameter optimization.</p>	



If for any reason you do not understand the test procedures or are unable to perform the tests/repairs safely, contact your Lincoln Authorized Service Facility for technical troubleshooting assistance before you proceed.

WWW.LINCOLNELECTRIC.COM/LOCATOR

DIAGRAMS

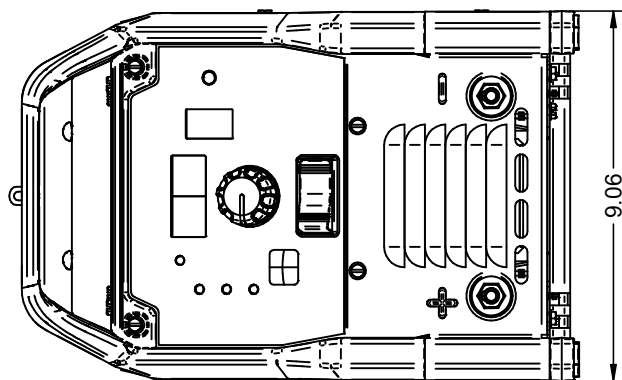
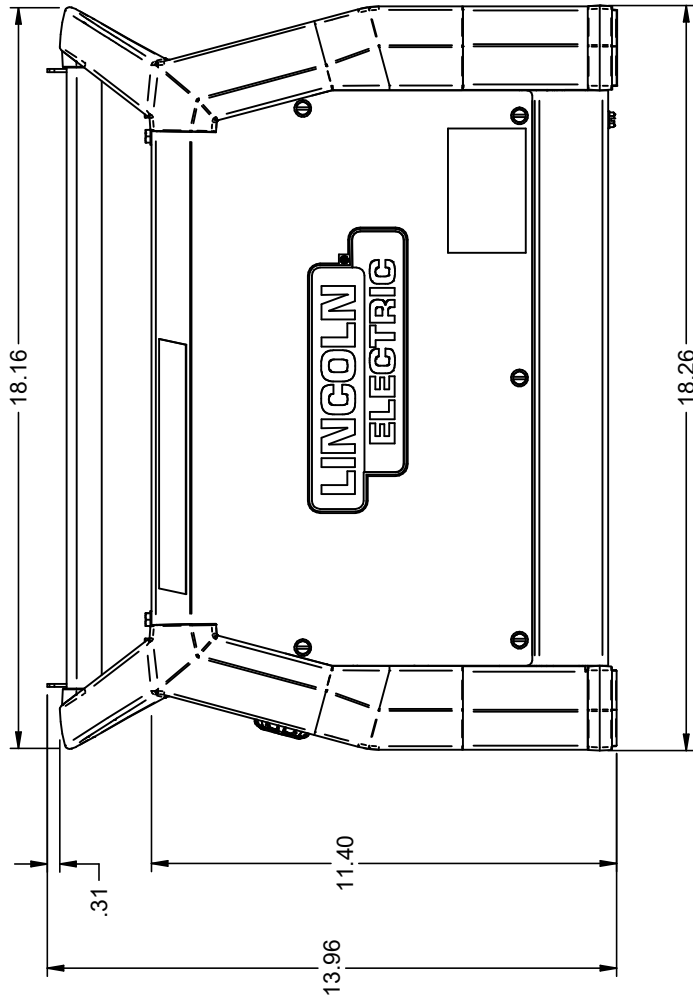

			
WARNING	<ul style="list-style-type: none"> ● Do not touch electrically live parts or electrode with skin or wet clothing. ● Insulate yourself from work and ground. 	<ul style="list-style-type: none"> ● Keep flammable materials away. 	<ul style="list-style-type: none"> ● Wear eye, ear and body protection.
Spanish AVISO DE PRECAUCION	<ul style="list-style-type: none"> ● No toque las partes o los electrodos bajo carga con la piel o ropa mojada. ● Aíslese del trabajo y de la tierra. 	<ul style="list-style-type: none"> ● Mantenga el material combustible fuera del área de trabajo. 	<ul style="list-style-type: none"> ● Protéjase los ojos, los oídos y el cuerpo.
French ATTENTION	<ul style="list-style-type: none"> ● Ne laissez ni la peau ni des vêtements mouillés entrer en contact avec des pièces sous tension. ● Isolez-vous du travail et de la terre. 	<ul style="list-style-type: none"> ● Gardez à l'écart de tout matériel inflammable. 	<ul style="list-style-type: none"> ● Protégez vos yeux, vos oreilles et votre corps.
German WARNUNG	<ul style="list-style-type: none"> ● Berühren Sie keine stromführenden Teile oder Elektroden mit Ihrem Körper oder feuchter Kleidung! ● Isolieren Sie sich von den Elektroden und dem Erdboden! 	<ul style="list-style-type: none"> ● Entfernen Sie brennbares Material! 	<ul style="list-style-type: none"> ● Tragen Sie Augen-, Ohren- und Körperschutz!
Portuguese ATENÇÃO	<ul style="list-style-type: none"> ● Não toque partes elétricas e electrodos com a pele ou roupa molhada. ● Isole-se da peça e terra. 	<ul style="list-style-type: none"> ● Mantenha inflamáveis bem guardados. 	<ul style="list-style-type: none"> ● Use proteção para a vista, ouvido e corpo.
Japanese 注意事項	<ul style="list-style-type: none"> ● 通電中の電気部品、又は溶材にヒフやぬれた布で触れないこと。 ● 施工物やアースから身体が絶縁されている様にして下さい。 	<ul style="list-style-type: none"> ● 燃えやすいものの側での溶接作業は絶対にしてはなりません。 	<ul style="list-style-type: none"> ● 目、耳及び身体に保護具をして下さい。
Chinese 警告	<ul style="list-style-type: none"> ● 皮肤或湿衣物切勿接触带电部件及焊条。 ● 使你自已与地面和工件绝缘。 	<ul style="list-style-type: none"> ● 把一切易燃物品移离工作场所。 	<ul style="list-style-type: none"> ● 佩戴眼、耳及身体劳动保护用具。
Korean 위험	<ul style="list-style-type: none"> ● 전도체나 용접봉을 젖은 헝겍 또는 피부로 절대 접촉치 마십시오. ● 모재와 접지를 접촉치 마십시오. 	<ul style="list-style-type: none"> ● 인화성 물질을 접근시키지 마시오. 	<ul style="list-style-type: none"> ● 눈, 귀와 몸에 보호장구를 착용하십시오.
Arabic تحذير	<ul style="list-style-type: none"> ● لا تلمس الاجزاء التي يسري فيها التيار الكهربائي أو الألكترود بجند الجسم أو بالملابس المبللة بالماء. ● ضع عازلا على جسمك خلال العمل. 	<ul style="list-style-type: none"> ● ضع المواد القابلة للاشتعال في مكان بعيد. 	<ul style="list-style-type: none"> ● ضع أدوات وملابس واقية على عينيك وأذنيك وجسمك.

READ AND UNDERSTAND THE MANUFACTURER'S INSTRUCTION FOR THIS EQUIPMENT AND THE CONSUMABLES TO BE USED AND FOLLOW YOUR EMPLOYER'S SAFETY PRACTICES.

SE RECOMIENDA LEER Y ENTENDER LAS INSTRUCCIONES DEL FABRICANTE PARA EL USO DE ESTE EQUIPO Y LOS CONSUMIBLES QUE VA A UTILIZAR, SIGA LAS MEDIDAS DE SEGURIDAD DE SU SUPERVISOR.

LISEZ ET COMPRENEZ LES INSTRUCTIONS DU FABRICANT EN CE QUI REGARDE CET EQUIPMENT ET LES PRODUITS A ETRE EMPLOYES ET SUIVEZ LES PROCEDURES DE SECURITE DE VOTRE EMPLOYEUR.

LESEN SIE UND BEFOLGEN SIE DIE BETRIEBSANLEITUNG DER ANLAGE UND DEN ELEKTRODENEINSATZ DES HERSTELLERS. DIE UNFALLVERHÜTUNGSVORSCHRIFTEN DES ARBEITGEBERS SIND EBENFALLS ZU BEACHTEN.

			
<ul style="list-style-type: none"> ● Keep your head out of fumes. ● Use ventilation or exhaust to remove fumes from breathing zone. 	<ul style="list-style-type: none"> ● Turn power off before servicing. 	<ul style="list-style-type: none"> ● Do not operate with panel open or guards off. 	WARNING
<ul style="list-style-type: none"> ● Los humos fuera de la zona de respiración. ● Mantenga la cabeza fuera de los humos. Utilice ventilación o aspiración para gases. 	<ul style="list-style-type: none"> ● Desconectar el cable de alimentación de poder de la máquina antes de iniciar cualquier servicio. 	<ul style="list-style-type: none"> ● No operar con panel abierto o guardas quitadas. 	Spanish AVISO DE PRECAUCION
<ul style="list-style-type: none"> ● Gardez la tête à l'écart des fumées. ● Utilisez un ventilateur ou un aspirateur pour ôter les fumées des zones de travail. 	<ul style="list-style-type: none"> ● Débranchez le courant avant l'entretien. 	<ul style="list-style-type: none"> ● N'opérez pas avec les panneaux ouverts ou avec les dispositifs de protection enlevés. 	French ATTENTION
<ul style="list-style-type: none"> ● Vermeiden Sie das Einatmen von Schweißrauch! ● Sorgen Sie für gute Be- und Entlüftung des Arbeitsplatzes! 	<ul style="list-style-type: none"> ● Strom vor Wartungsarbeiten abschalten! (Netzstrom völlig öffnen; Maschine anhalten!) 	<ul style="list-style-type: none"> ● Anlage nie ohne Schutzgehäuse oder Innenschutzverkleidung in Betrieb setzen! 	German WARNUNG
<ul style="list-style-type: none"> ● Mantenha seu rosto da fumaça. ● Use ventilação e exaustão para remover fumo da zona respiratória. 	<ul style="list-style-type: none"> ● Não opere com as tampas removidas. ● Desligue a corrente antes de fazer serviço. ● Não toque as partes elétricas nuas. 	<ul style="list-style-type: none"> ● Mantenha-se afastado das partes moventes. ● Não opere com os painéis abertos ou guardas removidas. 	Portuguese ATENÇÃO
<ul style="list-style-type: none"> ● ヒュームから頭を離すようにして下さい。 ● 換気や排煙に十分留意して下さい。 	<ul style="list-style-type: none"> ● メンテナンス・サービスに取りかかる際には、まず電源スイッチを必ず切して下さい。 	<ul style="list-style-type: none"> ● パネルやカバーを取り外したままで機械操作をしないで下さい。 	Japanese 注意事項
<ul style="list-style-type: none"> ● 頭部遠離煙霧。 ● 在呼吸區使用通風或排風器除煙。 	<ul style="list-style-type: none"> ● 維修前切斷電源。 	<ul style="list-style-type: none"> ● 儀表板打開或沒有安全罩時不準作業。 	Chinese 警告
<ul style="list-style-type: none"> ● 얼굴로부터 용접가스를 멀리하십시오. ● 호흡지역으로부터 용접가스를 제거하기 위해 가스제거기나 통풍기를 사용하십시오. 	<ul style="list-style-type: none"> ● 보수전에 전원을 차단하십시오. 	<ul style="list-style-type: none"> ● 관널이 열린 상태로 작동치 마십시오. 	Korean 위험
<ul style="list-style-type: none"> ● ابعد رأسك بعيداً عن الدخان. ● استعمل التهوية أو جهاز ضغط الدخان للخارج لكي تبعد الدخان عن المنطقة التي تتنفس فيها. 	<ul style="list-style-type: none"> ● أقطع التيار الكهربائي قبل القيام بأية صيانة. 	<ul style="list-style-type: none"> ● لا تشغيل هذا الجهاز اذا كانت الاغطية الحديدية الواقية ليست عليه. 	Arabic تحذير

LEIA E COMPREENDA AS INSTRUÇÕES DO FABRICANTE PARA ESTE EQUIPAMENTO E AS PARTES DE USO, E SIGA AS PRÁTICAS DE SEGURANÇA DO EMPREGADOR.

使う機械や溶材のメーカーの指示書をよく読み、まず理解して下さい。そして貴社の安全規定に従って下さい。

請詳細閱讀並理解製造廠提供的說明以及應該使用的銀焊材料，並請遵守貴方的有關勞動保護規定。

이 제품에 동봉된 작업지침서를 숙지하시고 귀사의 작업자 안전수칙을 준수하시기 바랍니다.

اقرأ بتمعن وافهم تعليمات المصنع المنتج لهذه المعدات والمواد قبل استعمالها واتبع تعليمات الوقاية لصاحب العمل.

CUSTOMER ASSISTANCE POLICY

The business of Lincoln Electric is manufacturing and selling high quality welding equipment, automated welding systems, consumables, and cutting equipment. Our challenge is to meet the needs of our customers, who are experts in their fields, and to exceed their expectations. On occasion, purchasers may ask Lincoln Electric for information or technical information about their use of our products. Our employees respond to inquiries to the best of their ability based on information and specifications provided to them by the customers and the knowledge they may have concerning the application. Our employees, however, are not in a position to verify the information provided or to evaluate the engineering requirements for the particular weldment, or to provide engineering advice in relation to a specific situation or application. Accordingly, Lincoln Electric does not warrant or guarantee or assume any liability with respect to such information or communications. Moreover, the provision of such information or technical information does not create, expand, or alter any warranty on our products. Any express or implied warranty that might arise from the information or technical information, including any implied warranty of merchantability or any warranty of fitness for any customers' particular purpose or any other equivalent or similar warranty is specifically disclaimed.

Lincoln Electric is a responsive manufacturer, but the definition of specifications, and the selection and use of specific products sold by Lincoln Electric is solely within the control of, and remains the sole responsibility of the customer. Many variables beyond the control of Lincoln Electric affect the results obtained in applying these types of fabrication methods and service requirements.

WELD FUME CONTROL EQUIPMENT

The operation of welding fume control equipment is affected by various factors including proper use and positioning of the equipment, maintenance of the equipment and the specific welding procedure and application involved. Worker exposure level should be checked upon installation and periodically thereafter to be certain it is within applicable OSHA PEL and ACGIH TLV limits.



THE LINCOLN ELECTRIC COMPANY

22801 St. Clair Avenue • Cleveland, OH • 44117-1199 • U.S.A.
Phone: +1.216.481.8100 • www.lincolnelectric.com