

INSTRUCTION MANUAL

RANGER[®] 260MPX & 330MPX

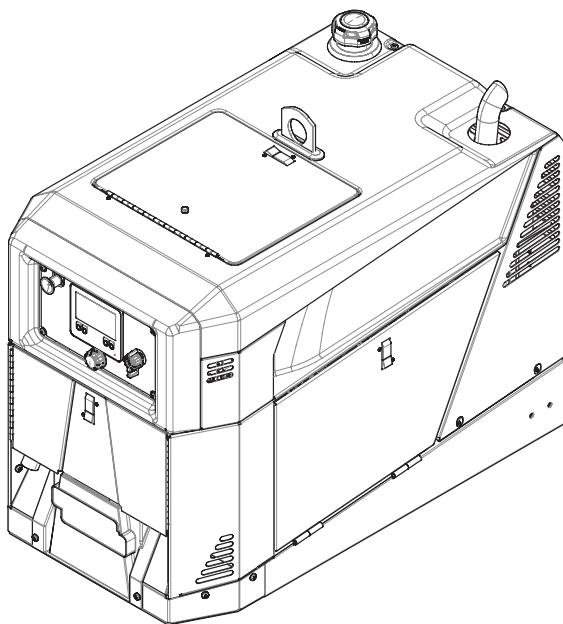

For use with Product/Code
Numbers:

12646, 13011, 13648,
13651, 13804, 13805,
13649, 13806

Save for future reference

Date Purchased

Code: (ex: 10859)

Serial: (ex: U1060512345)

Contents

INSTALLATION..... SECTION A

TECHNICAL SPECIFICATIONS - 260MPX CARB.....	A-1
TECHNICAL SPECIFICATIONS - 330MPX CARB.....	A-1
TECHNICAL SPECIFICATIONS - 330 MPX RFI.....	A-2
TECHNICAL SPECIFICATIONS - RHELKO ENGINES.....	A-3
GENERAL DESCRIPTION.....	A-4
SAFETY PRECAUTIONS.....	A-4
SERVICE TRUCK AND TRAILER INSTALLATION.....	A-6
LOCATION AND VENTILATION.....	A-7
ENVIRONMENTAL LIMITATIONS.....	A-7
TILTING.....	A-7
LIFTING.....	A-7
BATTERY CONNECTION.....	A-8
WELD CONNECTIONS.....	A-9
WELD CABLES, STANDARD.....	A-10
STICK WELDING SET-UP.....	A-10
WIRE WELDING SET-UP.....	A-11
DC TIG WELDING SET-UP.....	A-13
AC TIG WELDING SET-UP.....	A-14
FUEL - USE GASOLINE FUEL ONLY.....	A-15
OIL.....	A-15
SPARK ARRESTOR.....	A-16
MACHINE GROUNDING.....	A-16
AUXILIARY POWER.....	A-17

OPERATION..... SECTION B

SAFETY PRECAUTIONS.....	B-1
GRAPHIC SYMBOLS.....	B-2
CASE FRONT CONTROLS.....	B-3
WELDING.....	B-4
DISPLAY OPERATION.....	B-4
HOME SCREEN.....	B-5
WELD SCREENS, MANUAL ENTRY.....	B-5
WELD SCREENS, READY.SET.WELD.....	B-6
CROSSLINC.....	B-7
REMOTE CONTROL.....	B-8
SPOOL GUN OPTIONS (*RANGER 330MPX ONLY).....	B-10
SPOOL GUN PULSE (*RANGER 330MPX ONLY).....	B-11
SPOT TIME (RANGER 330MPX ONLY).....	B-11
WELD SETTING MEMORY.....	B-12
ARC OPTIONS.....	B-12
ENGINE STATUS SCREEN.....	B-13
FUEL CONSUMPTION CURVE.....	B-14
BATTERY SAVER.....	B-14
AUXILIARY POWER.....	B-15
GFCI MODULE.....	B-16
AUXILIARY POWER OPERATION.....	B-17
OVERLOAD PROTECTION.....	B-17
SIMULTANEOUS WELD AND POWER TABLE.....	B-17
SET-UP MENU.....	B-18

SECURITY.....	B-19
ENGINE SERVICE TIME (*CHOPPER SOFTWARE VERSION S32664-6 AND EARLIER).....	B-20
WELD MODE SELECT.....	B-21
CLOCK.....	B-22
SPOOL GUN CALIBRATION.....	B-22
DIAGNOSTIC INFORMATION.....	B-24
FUEL PURGE.....	B-24
DEMO MODE.....	B-24

ACCESSORIES AND OPTIONS..... SECTION C

ACCESSORIES.....	C-1
------------------	-----

MAINTENANCE..... SECTION D

SAFETY PRECAUTIONS.....	D-1
OIL AND OIL FILTER CHANGE.....	D-1
AIR FILTER CHANGE.....	D-2
FUEL FILTER.....	D-2
SPARK PLUG SERVICING.....	D-3
ENGINE SPEED ADJUSTMENT.....	D-3
BATTERY MAINTENANCE.....	D-4
SPARK ARRESTOR SERVICING.....	D-5
STORAGE.....	D-5
WELDER GENERATOR MAINTENANCE.....	D-5
BRUSH REMOVAL AND REPLACEMENT.....	D-5
NORMAL SERVICE INTERVALS.....	D-7

TROUBLESHOOTING..... SECTION E

HOW TO USE TROUBLESHOOTING GUIDE.....	E-1
TROUBLESHOOTING GUIDE.....	E-1

WIRING DIAGRAM - G9203

WIRING DIAGRAM - G9203

WIRING DIAGRAM - G10114

WIRING DIAGRAM - G10114

DIMENSIONS

CUSTOMER ASSISTANCE POLICY



SAFETY INFORMATION

SAFETY DEPENDS ON YOU

Lincoln welding and cutting equipment is designed and built with safety in mind. However, your overall safety can be increased by proper installation ... and thoughtful operation on your part. **DO NOT INSTALL, OPERATE OR REPAIR THIS EQUIPMENT WITHOUT READING THIS MANUAL AND THE SAFETY PRECAUTIONS CONTAINED THROUGHOUT.** And, most importantly, think before you act and be careful.

 DANGER	
	This statement indicates an imminently hazardous situation which, if not avoided, will result in death or serious injury.

 WARNING	
	This statement indicates a potentially hazardous situation which, if not avoided, could result in death or serious injury.

 CAUTION	
	This statement indicates a potentially hazardous situation which, if not avoided, could result in minor or moderate injury.

Notice: This statement indicates the possibility of damage to equipment if the potential risk is not avoided.

PLEASE EXAMINE CARTON AND EQUIPMENT FOR DAMAGE IMMEDIATELY

When this equipment is shipped, title passes to the purchaser upon receipt by the carrier. Consequently, claims for material damaged in shipment must be made by the purchaser against the transportation company at the time the shipment is received.

KEEP YOUR HEAD OUT OF THE FUMES



- **DON'T** get too close to the weld. Use corrective lenses if necessary to stay a reasonable distance away from the weld.
- **USE ENOUGH VENTILATION** or exhaust at the weld, or both, to keep the fumes and gases from your breathing zone and the general area.
- **IN A LARGE ROOM OR OUTDOORS**, natural ventilation may be adequate if you keep your head out of the fumes.
- **USE NATURAL DRAFTS** or fans to keep the fumes away from your face.
- **READ** and obey the Safety Data Sheet (SDS) and the warning label that appears on all containers of welding materials.

If you develop unusual symptoms, see your supervisor. Perhaps the welding atmosphere and ventilation system should be checked.

WEAR CORRECT EYE, EAR AND BODY PROTECTION



- **PROTECT** your eyes and face with properly fitted and with proper grade of filter plate (See ANSI Z49.1).
- **PROTECT** your body from welding spatter and arc flash with protective clothing including woolen clothing, flame-proof apron and gloves, leather leggings, and high boots.
- **PROTECT** others from spatter, flash, and glare with protective screens or barriers.
- **PROTECT** your eyes and face with welding helmet
- **IN SOME AREAS**, protection from noise may be appropriate.
- **BE SURE** protective equipment is in good condition.
- **AT ALL TIMES**, wear safety glasses in work area.



- **DO NOT WELD OR CUT** containers or materials which previously had been in contact with hazardous substances unless they are properly cleaned. This is extremely dangerous.

SAFETY INFORMATION

- **DO NOT WELD OR CUT** painted or plated parts unless special precautions with ventilation have been taken. They can release highly toxic fumes or gases.
- **PROTECT** compressed gas cylinders from excessive heat, mechanical shocks, and arcs; fasten cylinders so they cannot fall.
- **BE SURE** cylinders are never grounded or part of an electrical circuit.
- **REMOVE** all potential fire hazards from welding area.



- **ALWAYS HAVE FIRE FIGHTING EQUIPMENT READY FOR IMMEDIATE USE AND KNOW HOW TO USE IT.**

CALIFORNIA PROPOSITION 65 WARNINGS

WARNING	
	<p>Breathing diesel engine exhaust exposes you to chemicals known to the State of California to cause cancer and birth defects, or other reproductive harm.</p> <p>Always start and operate the engine in a well-ventilated area.</p> <p>If in an exposed area, vent the exhaust to the outside.</p> <p>Do not modify or tamper with the exhaust system.</p> <p>Do not idle the engine except as necessary.</p>

WARNING	
	<p>This product, when used for welding or cutting, produces fumes or gases which contain chemicals known to the State of California to cause birth defects and, in some cases, cancer. (California Health & Safety Code § 25249.5 et seq.)</p>

For more information go to <https://www.p65warnings.ca.gov>

ARC WELDING CAN BE HAZARDOUS

PROTECT YOURSELF AND OTHERS FROM POSSIBLE SERIOUS INJURY OR DEATH. KEEP CHILDREN AWAY. PACEMAKER WEARERS SHOULD CONSULT WITH THEIR DOCTOR BEFORE OPERATING.

Read and understand the following safety highlights. For additional safety information, it is strongly recommended that you purchase a copy of "Safety in Welding & Cutting - ANSI Standard Z49.1" from the American Welding Society, P.O. Box 351040, Miami, Florida 33135 or CSA Standard W117.2. A Free copy of "Arc Welding Safety" booklet E205 is available from the Lincoln Electric Company, 22801 St. Clair Avenue, Cleveland, Ohio 44117-1199.

BE SURE THAT ALL INSTALLATION, OPERATION, MAINTENANCE AND REPAIR PROCEDURES ARE PERFORMED ONLY BY QUALIFIED INDIVIDUALS.

FOR ENGINE POWERED EQUIPMENT



- Turn the engine off before troubleshooting and maintenance work unless the maintenance work requires it to be running.



- Do not add the fuel near an open flame welding arc or when the engine is running. Stop the engine and allow it to cool before refueling to prevent spilled fuel from vaporizing on contact with hot engine parts and igniting. Do not spill fuel when filling tank. If fuel is spilled, wipe it up and do not start engine until fumes have been eliminated.



- Keep all equipment safety guards, covers and devices in position and in good repair. Keep hands, hair, clothing and tools away from V-belts, gears, fans and all other moving parts when starting, operating or repairing equipment.

- In some cases it may be necessary to remove safety guards to perform required maintenance. **REMOVE GUARDS ONLY** when necessary and replace them when the maintenance requiring their removal is complete. Always use the greatest care when working near moving parts.
- **DO NOT** put your hands near the engine fan. Do not attempt to override the governor or idler by pushing on the throttle control rods while the engine is running.
- To prevent accidentally starting gasoline engines while turning the engine or welding generator during maintenance work, disconnect the spark plug wires, distributor cap or magneto wire as appropriate.



- To avoid scalding, do not remove the radiator pressure cap when the engine is hot.



- Generator exhaust contains carbon monoxide. This is a poison you cannot see or smell.
- Using a generator indoors **CAN KILL YOU IN MINUTES**.
- **NEVER** use inside a home or garage, **EVEN IF** doors and windows are open.
- **ONLY** use **OUTSIDE** and far away from windows, doors and vents.



- Avoid other generator hazards. **READ MANUAL BEFORE USE.**

ELECTRIC AND MAGNETIC FIELDS MAY BE DANGEROUS



- Electric current flowing through any conductor causes localized Electric and Magnetic Fields (EMF). Welding current creates EMF fields around welding cables and welding machines.
- EMF fields may interfere with some pacemakers, and welders having a pacemaker should consult their physician before welding.
- Exposure to EMF fields in welding may have other health effects which are now not known. All welders should use the following procedures in order to minimize exposure to EMF fields from the welding circuit:
 - Route the electrode and work cables together - Secure them with tape when possible.

- Never coil the electrode lead around your body.
- Do not place your body between the electrode and work cables. If the electrode cable is on your right side, the work cable should also be on your right side.
- Connect the work cable to the workpiece as close as possible to the area being welded.
- Do not work next to welding power source.

ELECTRIC SHOCK CAN KILL



- The electrode and work (or ground) circuits are electrically "hot" when the welder is on. Do not touch these "hot" parts with your bare skin or wet clothing. Wear dry, hole-free gloves to insulate hands.
- Insulate yourself from work and ground using dry insulation. Make certain the insulation is large enough to cover your full area of physical contact with work and ground.

In addition to the normal safety precautions, if welding must be performed under electrically hazardous conditions (in damp locations or while wearing wet clothing; on metal structures such as floors, gratings or scaffolds; when in cramped positions such as sitting, kneeling or lying, if there is a high risk of unavoidable or accidental contact with the workpiece or ground) use the following equipment:

- Semiautomatic DC Constant Voltage (Wire) Welder.
- DC Manual (Stick) Welder.
- AC Welder with Reduced Voltage Control.
- In semiautomatic or automatic wire welding, the electrode, electrode reel, welding head, nozzle or semiautomatic welding gun are also electrically "hot".
- Always be sure the work cable makes a good electrical connection with the metal being welded. The connection should be as close as possible to the area being welded.
- Ground the work or metal to be welded to a good electrical (earth) ground.
- Maintain the electrode holder, work clamp, welding cable and welding machine in good, safe operating condition. Replace damaged insulation.
- Never dip the electrode in water for cooling.

SAFETY INFORMATION

- Never simultaneously touch electrically “hot” parts of electrode holders connected to two welders because voltage between the two can be the total of the open circuit voltage of both welders.
- When working above floor level, use a safety belt to protect yourself from a fall should you get a shock.
- **Also see [WELDING AND CUTTING SPARKS CAN CAUSE FIRE OR EXPLOSION](#) and [FOR ELECTRICALLY POWERED EQUIPMENT](#)**

ARC RAYS CAN BURN



- Use a shield with the proper filter and cover plates to protect your eyes from sparks and the rays of the arc when welding or observing open arc welding. Headshield and filter lens should conform to ANSI Z87.1 standards.
- Use suitable clothing made from durable flame-resistant material to protect your skin and that of your helpers from the arc rays.
- Protect other nearby personnel with suitable, non-flammable screening and/or warn them not to watch the arc nor expose themselves to the arc rays or to hot spatter or metal.

FUMES AND GASES CAN BE DANGEROUS



- Welding may produce fumes and gases hazardous to health. Avoid breathing these fumes and gases. When welding, keep your head out of the fume. Use enough ventilation and/or exhaust at the arc to keep fumes and gases away from the breathing zone.
- **When welding hardfacing (see instructions on container or SDS) or on lead or cadmium plated steel and other metals or coatings which produce highly toxic fumes, keep exposure as low as possible and within applicable OSHA PEL and ACGIH TLV limits using local exhaust or mechanical ventilation unless exposure assessments indicate otherwise. In confined spaces or in some circumstances, outdoors, a respirator may**

also be required. Additional precautions are also required when welding on galvanized steel.

- The operation of welding fume control equipment is affected by various factors including proper use and positioning of the equipment, maintenance of the equipment and the specific welding procedure and application involved. Worker exposure level should be checked upon installation and periodically thereafter to be certain it is within applicable OSHA PEL and ACGIH TLV limits.
- Do not weld in locations near chlorinated hydrocarbon vapors coming from degreasing, cleaning or spraying operations. The heat and rays of the arc can react with solvent vapors to form phosgene, a highly toxic gas, and other irritating products.
- Shielding gases used for welding can displace air and cause injury or death. Always use enough ventilation, especially in confined areas, to insure breathing air is safe.
- Read and understand the manufacturer’s instructions for this equipment and the consumables to be used, including the Safety Data Sheet (SDS) and follow your employer’s safety practices. SDS forms are available from your welding distributor or from the manufacturer.
- Also see [FOR ENGINE POWERED EQUIPMENT](#)

WELDING AND CUTTING SPARKS CAN CAUSE FIRE OR EXPLOSION



- Remove fire hazards from the welding area. If this is not possible, cover them to prevent the welding sparks from starting a fire. Remember that welding sparks and hot materials from welding can easily go through small cracks and openings to adjacent areas. Avoid welding near hydraulic lines. Have a fire extinguisher readily available.
- Where compressed gases are to be used at the job site, special precautions should be used to prevent hazardous situations. Refer to “**Safety in Welding and Cutting**” (ANSI Standard Z49.1) and the operating information for the equipment being used.

- When not welding, make certain no part of the electrode circuit is touching the work or ground. Accidental contact can cause overheating and create a fire hazard.
- Do not heat, cut or weld tanks, drums or containers until the proper steps have been taken to ensure that such procedures will not cause flammable or toxic vapors from substances inside. They can cause an explosion even though they have been “cleaned”. For information, purchase “Recommended Safe Practices for the Preparation for Welding and Cutting of Containers and Piping That Have Held Hazardous Substances”, **AWS F4.1** from the American Welding Society.
- Vent hollow castings or containers before heating, cutting or welding. They may explode.
- Sparks and spatter are thrown from the welding arc. Wear oil free protective garments such as leather gloves, heavy shirt, cuff-less trousers, high shoes and a cap over your hair. Wear ear plugs when welding out of position or in confined places. Always wear safety glasses with side shields when in a welding area.
- Connect the work cable to the work as close to the welding area as practical. Work cables connected to the building framework or other locations away from the welding area increase the possibility of the welding current passing through lifting chains, crane cables or other alternate circuits. This can create fire hazards or overheat lifting chains or cables until they fail.
- **Read and follow NFPA 51B** “Standard for Fire Prevention During Welding, Cutting and Other Hot Work”, available from NFPA, 1 Batterymarch Park, PO box 9101, Quincy, MA 02269-9101.
- **DO NOT** use a welding power source for pipe thawing.

CYLINDER MAY EXPLODE IF DAMAGED



- Use only compressed gas cylinders containing the correct shielding gas for the process used and properly operating regulators designed for the gas and pressure used. All hoses, fittings, etc. should be suitable for the application and maintained in good condition.

- Always keep cylinders in an upright position securely chained to an undercarriage or fixed support.

Cylinders should be located:

- Away from areas where they may be struck or subjected to physical damage.
- A safe distance from arc welding or cutting operations and any other source of heat, sparks, or flame.
- Never allow the electrode, electrode holder or any other electrically “hot” parts to touch a cylinder.
- Keep your head and face away from the cylinder valve outlet when opening the cylinder valve.
- Valve protection caps should always be in place and hand tight except when the cylinder is in use or connected for use.
- Read and follow the instructions on compressed gas cylinders, associated equipment, and CGA publication P-1, “Precautions for Safe Handling of Compressed Gases in Cylinders,” available from the Compressed Gas Association, 14501 George Carter Way Chantilly, VA 20151.

FOR ELECTRICALLY POWERED EQUIPMENT



- Turn off input power using the disconnect switch at the fuse box before working on the equipment.
- Install equipment in accordance with the U.S. National Electrical Code, all local codes and the manufacturer’s recommendations.
- Ground the equipment in accordance with the U.S. National Electrical Code and the manufacturer’s recommendations.

BATTERY HANDLING, STORAGE, AND DISPOSAL



Batteries can be flammable substances such as lithium or other organic solvents, which may result in overheating, rupture, or combustion. Failure to follow the battery manufactures instructions may result in fire, personal injury, and damage to property if used improperly.

SAFETY INFORMATION

- DO NOT short circuit, disassemble, deform, or heat batteries.
- DO NOT attempt to recharge batteries unless they are specifically marked as "rechargeable".
- DO NOT use or charge the battery if it appears to be leaking, deformed or damaged in any way.
- Store in a cool location. Keep batteries away from direct sunlight, high temperature, and high humidity.
- Immediately discontinue use of the battery if, while using, charging, or storing the battery, the battery emits an unusual smell, feels hot, changes color, changes shape, or appears abnormal in any other way.
- Keep batteries out of reach of children, should a child swallow a battery, consult a physician immediately.
- Recycle or dispose of batteries in accordance with local and federal laws.
- All persons inside LCA must wear proper PPE to avoid eye or skin exposure to laser radiation. The end user's LSO shall select proper PPE including, but not limited to, heat-resistant gloves, flame-resistant clothing, laser safety eye wear and laser-safe helmets that conform to ANSI Z136.1 Optical Density requirements for the wavelength and output power of the laser in use. Standard safety glasses and welding helmets DO NOT provide adequate protection from laser beam hazards. Always inspect PPE for damage or improper fit before use.
- Only qualified persons shall install, operate or service this unit per ANSI Z136.1 standards and your LSO's instruction. Read and follow all labels and manuals before installing, operating, or servicing hand held any laser welding equipment.
- Do not operate outside of a LCA, or if the laser protective housing is modified or damaged, or if safety interlocks have been bypassed or otherwise defeated. Inspect all equipment and LCA for damage or tampering prior to use.
- Reflected beams from the laser can damage eyes and skin and can pose a fire risk. Prior to use, the LCA should be assessed by the LSO to understand the surfaces where hazardous reflected beams can exist. Never position yourself or flammable material in the anticipated laser beam path and take extra precautions when working on reflective materials like aluminum and stainless steel.
- Follow all standards, individual facility or building regulations, and national, state, and local codes.

FOR LASER EMITTING EQUIPMENT



- Hazardous Class 4 (IV) laser products emit invisible, infrared laser radiation which can permanently damage the eye's retina and/or cornea, burn skin, and pose a fire risk. End users shall assign a qualified Laser Safety Officer (LSO) who has the certifications required by applicable law/standards, have a documented Laser Safety Program and have a Laser Controlled Area (LCA) that confirms to ANSI Z136.1 & Z136.9.
- Do not operate laser before end user's LSO has completed a risk assessment and all the prescribed Risk Mitigations measures have been fully implemented. Ensure the laser is operated/demonstrated safely by trained personnel and that the environment surrounding the laser welding cell or laser-controlled area is safe for people nearby when the laser is in operation.
- Never point the laser at yourself or others. Never look directly into a laser aperture, even if wearing full eye protection.

DEALER LOCATOR & PRODUCT REGISTRATION

Register your machine:



<https://www.lincolnelectric.com/register>

Authorized Service and Distributor Locator:

<https://www.lincolnelectric.com/locator>

ADDITIONAL SAFETY INFORMATION

Refer to <http://www.lincolnelectric.com/safety> for additional safety information

INSTALLATION

TECHNICAL SPECIFICATIONS - 260MPX CARB

RANGER 260MPX (Rhelko CARB CH730 and CH740) (K3458-1)

WELDING RATED OUTPUT @ 104°F (40°C)				
WELDING PROCESS	MODEL	WELDING OUTPUT - IEC RATING Current/Voltage/Duty Cycle	OTHER RATINGS	MAXIMUM WELD OCV@ RATED LOAD RPM
DC STICK WELDING (CONSTANT CURRENT)	Ranger 260MPX	35A / 21.4V / 100 % - 231A / 29.2V / 100 %	260A / 26V / 100 %	85 VOLTS
TOUCH-START TIG	Ranger 260MPX	25A / 11V / 100 % - 260A / 20.4V / 100 %	260A / 26V / 100 %	24 VOLTS
DC MIG/FCAW WELDING (CONSTANT VOLTAGE)	Ranger 260MPX	35A / 15.8V / 100 % - 253A / 26.7V / 100 %	260A / 26V / 100 %	85 VOLTS

AUXILIARY OUTPUT @ 104 °F (40°C)					
PHASE	MODEL	CONTINUOUS	PEAK	RECEPTACLE	CIRCUIT BREAKER
SINGLE PHASE 60Hz	260MPX	9,500 WATTS	10,000 WATTS	120 VAC Duplex (5-20R) GFCI Protected	20 AMPS

Lift bail rating 1085 lb (492 kg) Maximum.

TECHNICAL SPECIFICATIONS - 330MPX CARB

RANGER 330MPX (Rhelko CARB CH740) (K3459-1)

WELDING RATED OUTPUT @ 104°F (40°C)				
WELDING PROCESS	MODEL	WELDING OUTPUT - IEC RATING Current/Voltage/Duty Cycle	OTHER RATINGS	MAXIMUM WELD OCV@ RATED LOAD RPM
DC STICK WELDING (CONSTANT CURRENT)	Ranger 330MPX	35A / 21.4V / 100 % - 292A / 31.7V / 100 %	330A / 28V / 100 %	85 VOLTS
DC PIPE WELDING	Ranger 330MPX	35A / 21.4V / 100 % - 292A / 31.7V / 100 %	330A / 28V / 100 %	85 VOLTS
TOUCH-START TIG	Ranger 330MPX	25A / 11V / 100% - 325A / 23.0V / 100 %	330A / 28V / 100 %	24 VOLTS
DC MIG/FCAW WELDING (CONSTANT VOLTAGE)	Ranger 330MPX	35A / 15.8V / 100 % - 312A / 29.6V / 100 %	330A / 28V / 100 %	85 VOLTS

INSTALLATION

WELDING RATED OUTPUT @ 104°F (40°C)				
WELDING PROCESS	MODEL	WELDING OUTPUT - IEC RATING Current/Voltage/Duty Cycle	OTHER RATINGS	MAXIMUM WELD OCV@ RATED LOAD RPM
DC ARC GOUGING	Ranger 330MPX		330A / 28V / 100 %	85 VOLTS

AUXILIARY OUTPUT @ 104 °F (40°C)					
PHASE	MODEL	CONTINUOUS	PEAK	RECEPTACLE	CIRCUIT BREAKER
SINGLE PHASE 60Hz	330MPX	10,000 WATTS	11,500 WATTS	120/240 VAC Dual Voltage Full KVA (14-50R)	20 AMPS
				240 VAC (6-50R)	50 AMPS

Lift bail rating 1085 lb (492 kg) Maximum.

TECHNICAL SPECIFICATIONS - 330 MPX RFI

RANGER 330MPX EFI (K4779-1)

WELDING RATED OUTPUT @ 104°F (40°C)					
WELDING PROCESS	MODEL	WELDING OUTPUT - IEC RATING Current/Voltage/Duty Cycle	OTHER RATINGS	MAXIMUM WELD OCV@ RATED LOAD RPM	
DC STICK WELDING (CONSTANT CURRENT)	Ranger 330MPX EFI	35A / 21.4V / 100 % 292A / 31.7V / 100 %	330A / 28V / 100 %	85 VOLTS	
DC PIPE WELDING	Ranger 330MPX EFI	35A / 21.4V / 100 % 292A / 31.7V / 100 %	330A / 28V / 100 %	85 VOLTS	
TOUCH-START TIG	Ranger 330MPX EFI	25A / 11V / 100% 325A / 23.0V / 100 %	330A / 28V / 100 %	24 VOLTS	
DC MIG/FCAW WELDING (CONSTANT VOLTAGE)	Ranger 330MPX EFI	35A / 15.8V / 100 % 312A / 29.6V / 100 %	330A / 28V / 100 %	85 VOLTS	
DC ARC GOUGING	Ranger 330MPX EFI	N/A	330A / 28V / 100 %	85 VOLTS	
AUXILIARY OUTPUT @ 104 °F (40°C)					
	MODEL	CONTINUOUS	PEAK	RECEPTACLE	CIRCUIT BREAKER

AUXILIARY OUTPUT @ 104 °F (40°C)					
SINGLE PHASE 60Hz	RANGER 330MPX EFI	10,000 WATTS	11,500 WATTS	120 VAC Duplex (5-20R) GFCI Protected	20 AMPS
				120/240 VAC Dual Voltage Full KVA (14-50R) 240 VAC (6-50R)	50 AMPS
				240 VAC (6-50R)	50 AMPS

Lift bail rating 1085 lb (492 kg) Maximum.

TECHNICAL SPECIFICATIONS - RHELKO ENGINES

ENGINE SPECIFICATIONS	
MAKE/MODEL	Rhelko CARB -CH730 (23.5 HP) CODE 13085 FOR RANGER 260MPX -CH740 (25 HP) CODE 12646 FOR RANGER 260MPX -CH740 (25 HP) ALL CODES FOR RANGER 330MPX
EPA EMISSION	EVAPORATIVE
DISPLACEMENT	44.2 CU. IN. (724 CC)
SPEED	3600 RPM @ FULL LOAD 2500 RPM @ LOW IDLE
WARRANTY (USA)	2 YEAR COMPLETE (PARTS AND LABOR) 3 YEAR MAJOR COMPONENTS (PARTS AND LABOR)
FUEL SYSTEM	ELECTRIC LIFT PUMP, CARBURETOR
AIR CLEANER	DUAL ELEMENT
LUBRICATION	FULL PRESSURE WITH FULL FLOW FILTER
ENGINE PROTECTION	LOW OIL PRESSURE "PROTECTION SWITCH"
CAPACITIES	FUEL: 11 GAL (41.6 L) GASOLINE OIL: 1.7 - 1.9 QTS (1.6 - 1.8 L) 10W-30
BATTERY	For machine code numbers 13651 and below: 12VDC BATTERY BCI GROUP SIZE 99 410 COLD CRANKING AMPS For machine code numbers 13804 and above: 12VDC BATTERY BCI GROUP SIZE 26 572 COLD CRANKING AMPS

IEC 60974-1; IP23

-10°C TO +40°C OPERATING RANGE.

INSTALLATION

ENGINE SPECIFICATIONS	
MAKE/MODEL	Rhelko -ECH740 (25 HP) FOR RANGER 330MPX EFI
EPA EMISSION	EVAPORATIVE
DISPLACEMENT	44.2 CU. IN. (724 CC)
SPEED	3600 RPM @ FULL LOAD 2500 RPM @ LOW IDLE
WARRANTY (USA)	2 YEAR COMPLETE (PARTS AND LABOR) 3 YEAR MAJOR COMPONENTS (PARTS AND LABOR)
BATTERY	For machine code numbers 13649 and below: 12VDC BATTERY BCI GROUP SIZE 99 410 COLD CRANKING AMPS
	For machine code numbers 13806 and above: 12VDC BATTERY BCI GROUP SIZE 26 572 COLD CRANKING AMPS
FUEL SYSTEM	ELECTRIC LIFT PUMP, AND ELECTRONIC FUEL INJECTION
AIR CLEANER	DUAL ELEMENT
LUBRICATION	FULL PRESSURE WITH FULL FLOW FILTER
ENGINE PROTECTION	LOW OIL PRESSURE
CAPACITIES	FUEL: 11 GAL (41.6 L) GASOLINE OIL: 1.7 - 1.9 QTS (1.6 - 1.8 L) 10W-30

IEC 60974-1; IP23

-10°C TO +40°C OPERATING RANGE.

GENERAL DESCRIPTION

The RANGER 260MPX & 330MPX are compact, versatile machines for a wide variety of applications. They are well suited for service trucks, maintenance, repairs, pipeline welding, farm and ranch work, and back-up power.

The small size and low weight allows more room for trucks to carry tools and other equipment.

The fully sealed display guides welders to the best settings for making a quality weld.

Low sound improves work place safety and may qualify the machine for low noise regions, such as near schools or hospitals.

Auxiliary power quality is the best in its class – less than 5% total harmonic distortion throughout the entire power range. Quality of the auxiliary power is fully independent of the weld setting.

Direct connect spool gun makes wire welding easy and inexpensive.

SAFETY PRECAUTIONS

Only qualified personnel should install, use, or service this equipment.

⚠ WARNING



Do not attempt to use this equipment until you have thoroughly read the engine manufacturer's manual supplied with your welder. It includes important safety precautions, detailed engine starting, operating and maintenance instructions, and parts lists.

⚠ WARNING



ELECTRIC SHOCK can kill.
 Do not touch electrically live parts or electrode with skin or wet clothing.
 Insulate yourself from work and ground.
 Always wear dry insulating gloves.

⚠ WARNING



ENGINE EXHAUST can kill.
 Use in open, well ventilated areas or vent exhaust outside.

⚠ WARNING



MOVING PARTS can injure.
 Do not operate with doors open or guards off.
 Stop engine before servicing.
 Keep away from moving parts.

See additional warning information at front of this operator's manual.

SERVICE TRUCK AND TRAILER INSTALLATION

⚠ WARNING



- Improperly mounted concentrated loads may cause unstable vehicle handling and tires or other components to fail.
- Only transport this welding equipment on serviceable vehicles which are rated and designed for such loads.
- Distribute, balance and secure loads so vehicle is stable under conditions of use.
- Do not exceed maximum rated loads for components such as suspension, axles and tires.
- Mount equipment base to metal bed or frame of vehicle. Do not mount the welder using rubber mounts.
- Follow vehicle manufacturer's instructions.
- Do not install equipment where air flow is restricted. Equipment or the engine may overheat.
- Do not weld on the base. Welding on the base may cause fuel tank explosion or fire.
- Always ground the equipment frame to the vehicle frame to prevent electric shock and static electricity hazards.
- Do not place propane or shielding gas tanks near hot air or exhaust.

The welder should be located to provide an unrestricted flow of clean, cool air to the cooling air inlets and to avoid heated air coming out of the welder recirculating back to the cooling air inlet. Also, locate the welder so that engine exhaust fumes are properly vented to an outside area.

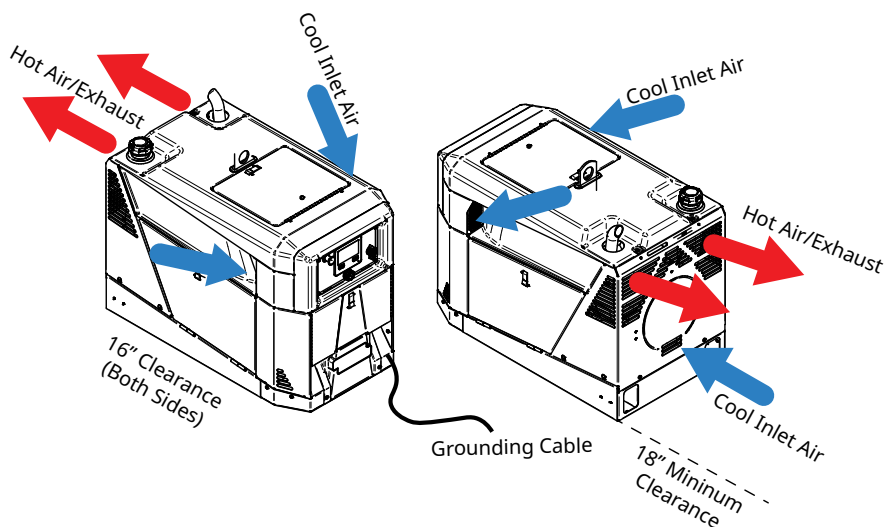



Figure 1 : SERVICE TRUCK AND TRAILER INSTALLATION

Connect a ground cable from the welder to the metal frame of the vehicle. Use insulated AWG #8 cable or larger (not supplied with the Ranger).

LOCATION AND VENTILATION

 CAUTION	
	<p>DO NOT MOUNT OVER COMBUSTIBLE SURFACES</p> <p>Where there is a combustible surface directly under stationary or fixed electrical equipment , that surface should be covered with a steel plate at least .06” (1.6 mm) thick, which should extend not less than 5.90” (150 mm) beyond the equipment on all sides.</p>

ENVIRONMENTAL LIMITATIONS

The RANGER 260MPX & 330MPX is IP23 rated for use in an outdoor environment. It should not be subjected to falling water during use nor should any parts of it be submerged in water. Doing so may cause improper operation as well as pose a safety hazard. The best practice is to keep the machine in a dry, sheltered area. Use a protective cover when not in use. See [ACCESSORIES AND OPTIONS](#) on page C-1

TILTING



Place the machine directly on a secure, level surface or on a recommended undercarriage or trailer. The machine may topple over if this procedure is not followed. The max weight the lift bale is rated for is in the [TECHNICAL SPECIFICATIONS](#) section.

Angle of Operation:

The maximum angle of continuous operation is 15°. Engine oil must be at FULL capacity. When operating at an angle, the effective fuel capacity will be reduced.

LIFTING

The RANGER 260MPX & 330MPX weigh approximately 515 lbs. (234 kg) each with a full tank of fuel, 446 lbs. (202kg) less fuel. The Ranger 330MPX EFI weighs 518 lbs. (235 kg) with a full tank of fuel, 449 lbs. (204 kg) less fuel. A lift bail is mounted to the machine and should always be used when lifting a machine.

 WARNING	
	<p>FALLING EQUIPMENT can cause injury</p> <p>Lift only with equipment of adequate lifting capacity.</p> <p>Be sure machine is stable when lifting.</p> <p>Do not lift this machine using lift bail if it is equipped with a heavy accessory such as trailer or gas cylinder.</p> <p>Do not lift machine if lift bail is damaged.</p> <p>Do not operate machine while suspended from lift bail.</p>

BATTERY CONNECTION

WARNING



GASES FROM BATTERY can explode.
Keep sparks, flame and cigarettes away from battery.

WARNING



To prevent EXPLOSION when:
INSTALLING A NEW BATTERY — disconnect negative cable from old battery first and connect to new battery last.
CONNECTING A BATTERY CHARGER — remove battery from welder by disconnecting negative cable first, then positive cable and battery clamp. When reinstalling, connect Negative cable last. Keep well ventilated.
USING A BOOSTER — connect positive lead to battery first then connect negative lead to negative battery lead at engine foot.

WARNING



BATTERY ACID can burn eyes and skin.
Wear gloves and eye protection and be careful when working near battery.
Follow instructions printed on battery.

IMPORTANT



To prevent ELECTRICAL DAMAGE WHEN:
a) Installing new battery.
b) Using a booster.
Use correct polarity — **NEGATIVE GROUND**.

These welders are shipped with the negative battery cable disconnected. Make sure that the Engine Switch is in the "OFF" position. Attach the disconnected cable securely to the negative battery terminal before attempting to operate the machine. If the battery is discharged and does not have enough power to start the engine, see the battery charging instructions in the Battery section. See [Figure 2 : BATTERY CONNECTION](#) on page A-9 .

Note: These machines are furnished with a wet charged battery; if unused for several months, the battery may require a booster charge. Be careful to charge the battery with the correct polarity.

To access the battery, turn the machine OFF. Remove the screws holding the battery cover and then slide battery out. When reinstalling, battery cables must be tightly assembled. Do not pinch battery leads between battery, cover or welder frame.

Always disconnect the negative (-) battery cable before charging the battery.

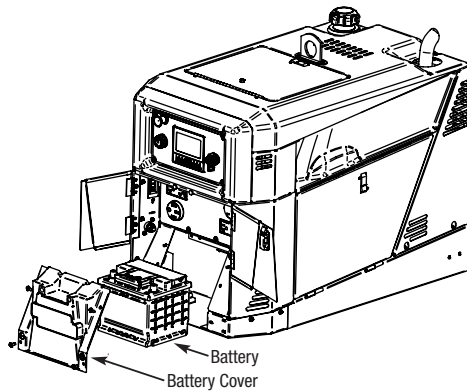

Figure 2 : BATTERY CONNECTION

WELD CONNECTIONS

⚠ WARNING



Turn the machine OFF before connecting/disconnecting welding equipment.

Loose connections will cause the output terminals to overheat. The terminals may eventually melt.

Do not allow bare weld cable to touch the machine or front doors.

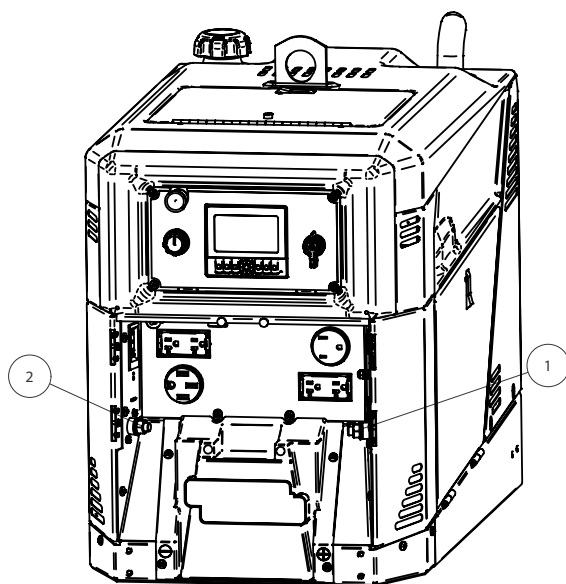

Figure 3 : WELD CONNECTIONS

1. Positive (+) weld terminal
2. Negative (-) weld terminal

For most stick, gouging, MIG and gas shielded flux cored welding procedures, connect the wire feeder or spool gun to the Positive (+) terminal and the work lead to the Negative terminal.

For most self-shielded flux cored and TIG procedures, connect the electrode holder or wire feeder to the Negative (-) terminal and the work lead to the Positive (+) terminal.

WELD CABLES, STANDARD

Tabulated below are copper cable sizes recommended for different currents and duty cycles. Lengths stipulated are the distance from the welder to work and back to the welder again. Cable sizes are increased for greater lengths primarily for the purpose of minimizing cable drop.

Table 1 :RECOMMENDED CABLE SIZES (RUBBER COVERED COPPER-RATED 75° C)**

Amperes	Percent Duty Cycle	CABLE SIZES FOR COMBINED LENGTHS OF ELECTRODE AND WORK CABLES				
		0 to 50 Ft.	50 to 100 Ft.	100 to 150 Ft.	150 to 200 Ft.	200 to 250 Ft.
200	60	2	2	2	1	1/0
200	100	2	2	2	1	1/0
225	20	4 or 5	3	2	1	1/0
225	40 & 30	3	3	2	1	1/0
250	30	3	3	2	1	1/0
250	40	2	2	1	1	1/0
250	60	1	1	1	1	1/0
250	100	1	1	1	1	1/0
300	60	1	1	1	1/0	2/0
325	100	2/0	2/0	2/0	2/0	3/0
350	60	1/0	1/0	2/0	2/0	3/0

** Tabled values are for operation at ambient temperatures of 40°C and below. Applications above 40°C may require cables larger than recommended, or cables rated higher than 75°C

STICK WELDING SET-UP

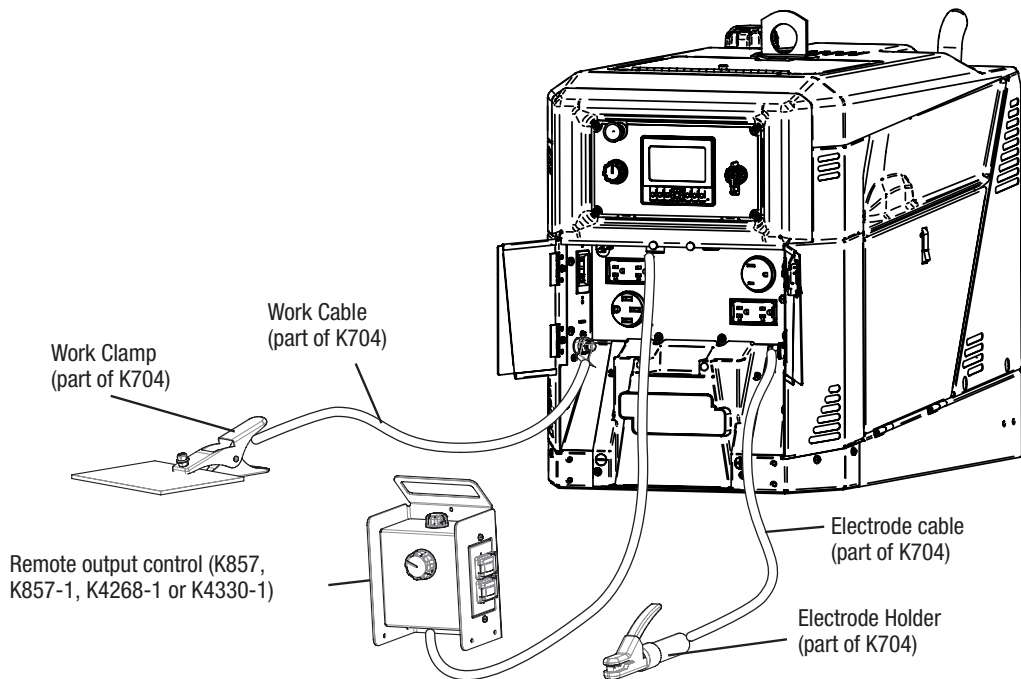

Figure 4 : Standard Stick Setup - Electrode Positive (+) shown

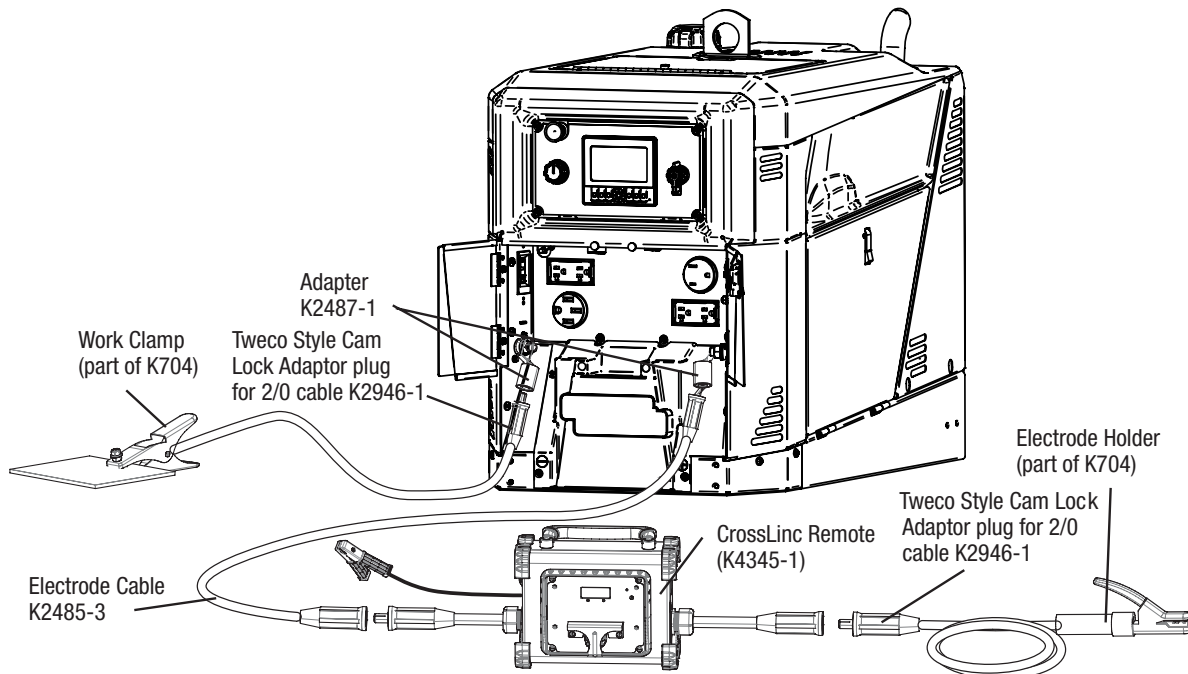

Figure 5 : CrossLinc Setup - Electrode Positive (+) shown

WIRE WELDING SET-UP

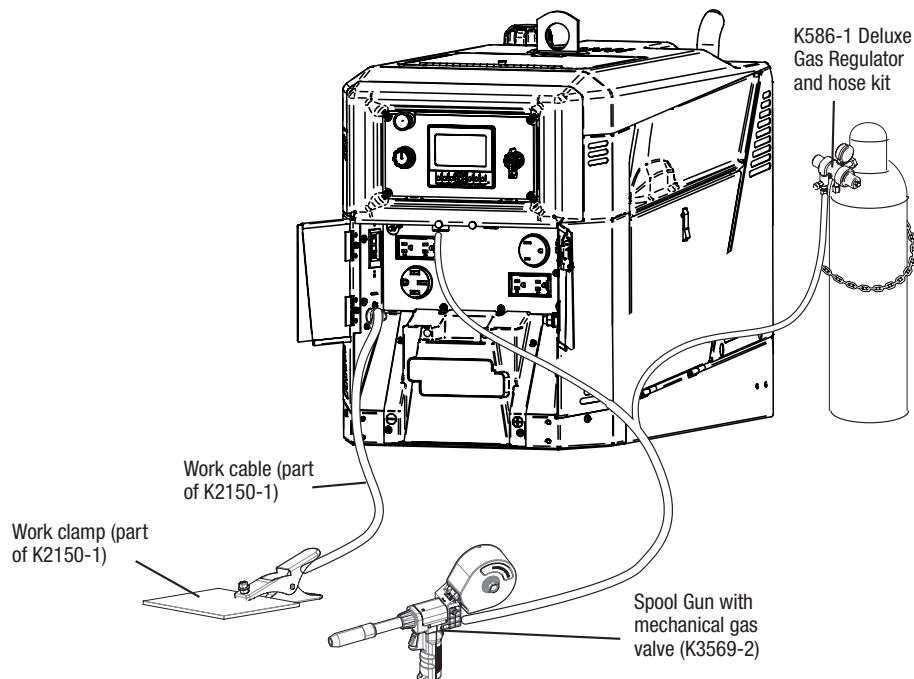

Figure 6 : Spool Gun Setup - Electrode Positive (+) shown

In the spool gun mode, the weld output is controlled by the trigger of the spool gun. The knob on the Ranger display sets voltage and the spool gun knob sets wire feed speed. Rotating the knob on the spool gun adjusts the work point (wire feed speed). Spool gun modes have the option of being “synergic” (when

INSTALLATION

the wire feed speed is changed, the voltage is automatically modified up or down to maintain a similar arc length).

If desired, a remote can be plugged into the 6 pin connector for setting the voltage away from the Ranger.

The best spool gun operation is obtained with the Magnum Pro 250 LX GT spool gun with mechanical gas flow trigger and Magnum Pro consumables. The standard Magnum PRO 250 LX gun is also supported but requires an external gas control. The Magnum SG spool gun and Magnum PRO 100 SG spool gun are not supported.

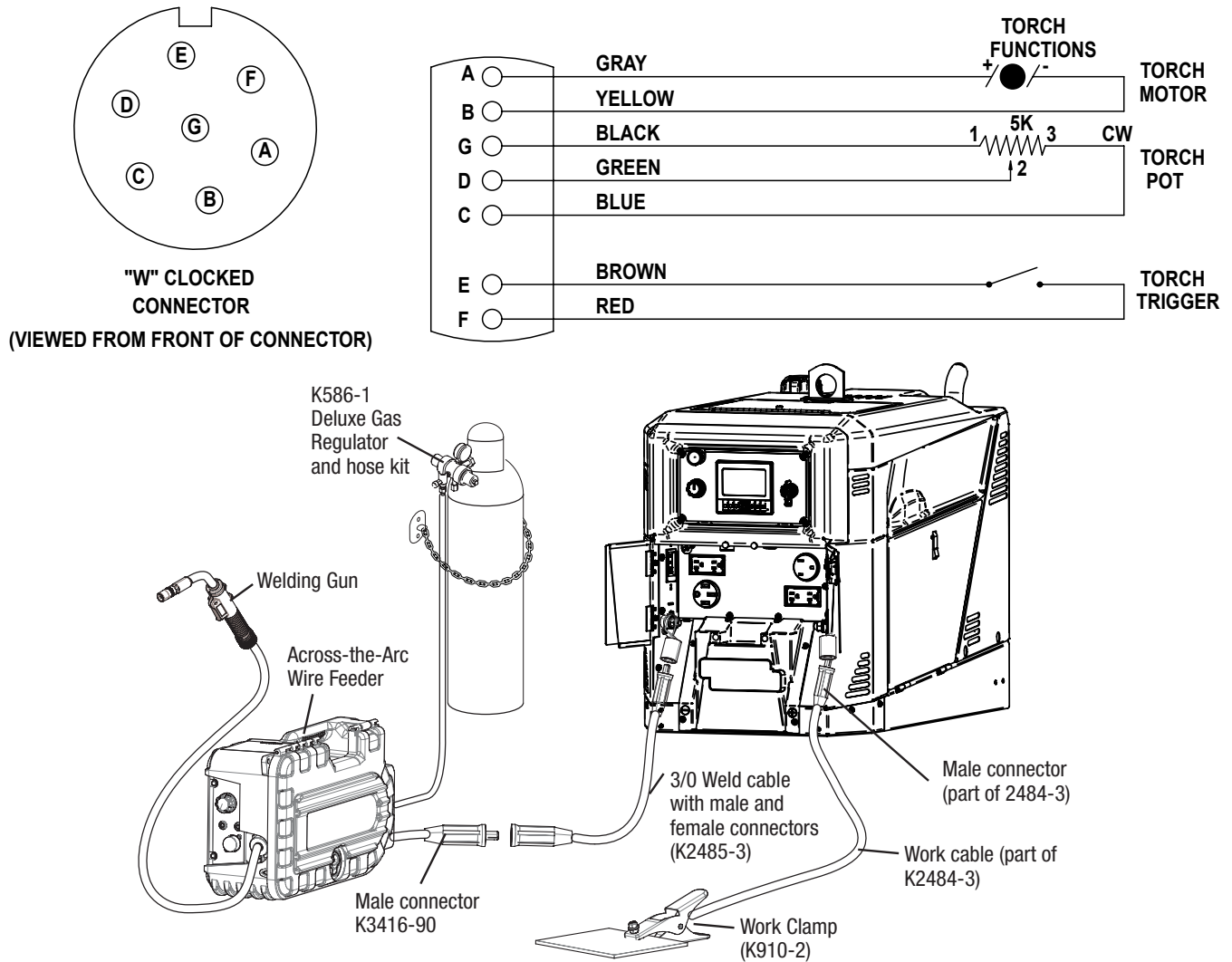

Figure 7 : Across the Arc Feeder Setup - Electrode Negative (-) shown

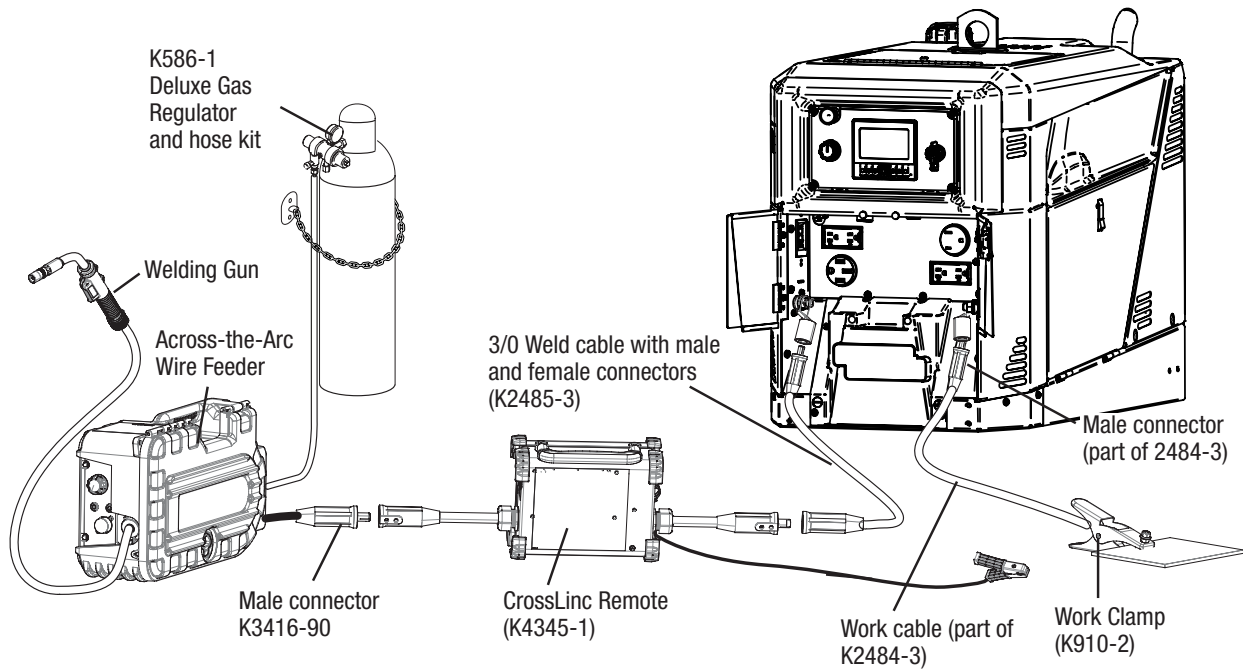

Figure 8 : Across the Arc Feeder Setup with CrossLinc Remote - Electrode Negative (-) shown

DC TIG WELDING SET-UP

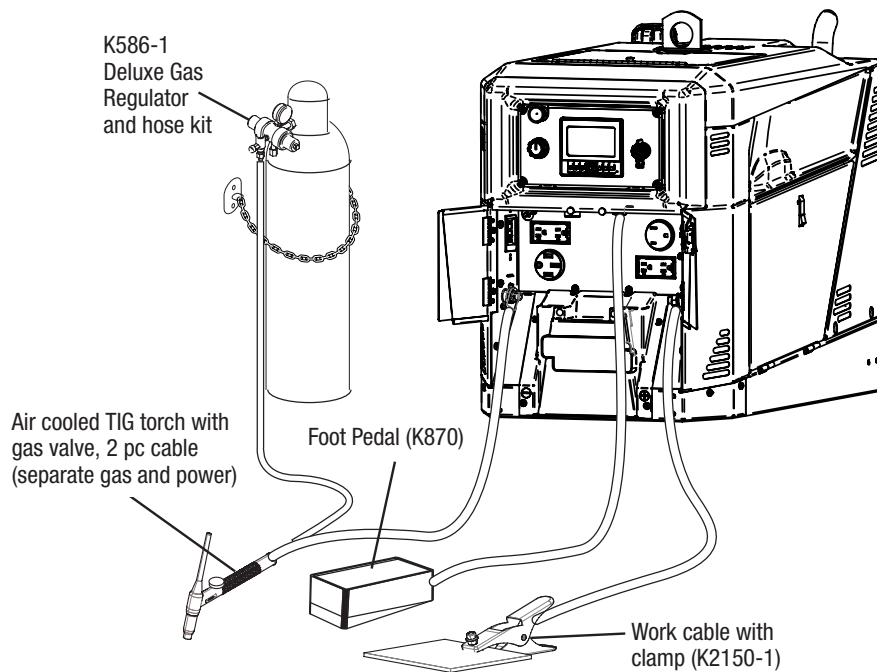

Figure 9 : DC TIG Setup with no High Frequency - Electrode Negative (-) Shown

INSTALLATION

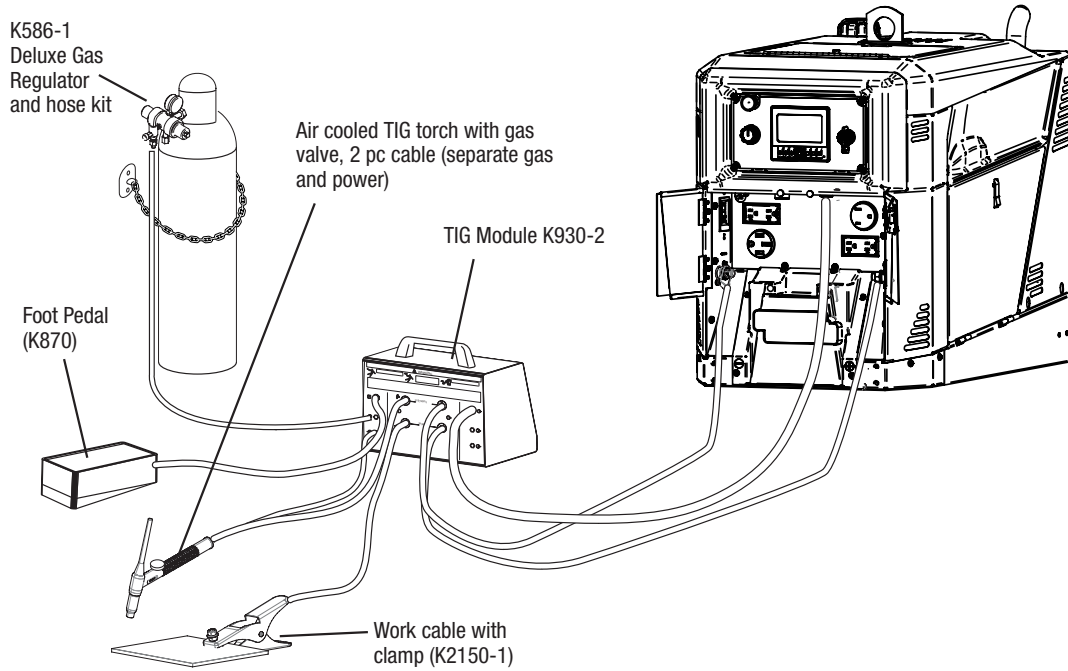

Figure 10 : DC TIG Setup with High Frequency - Electrode Negative (-) Shown

AC TIG WELDING SET-UP

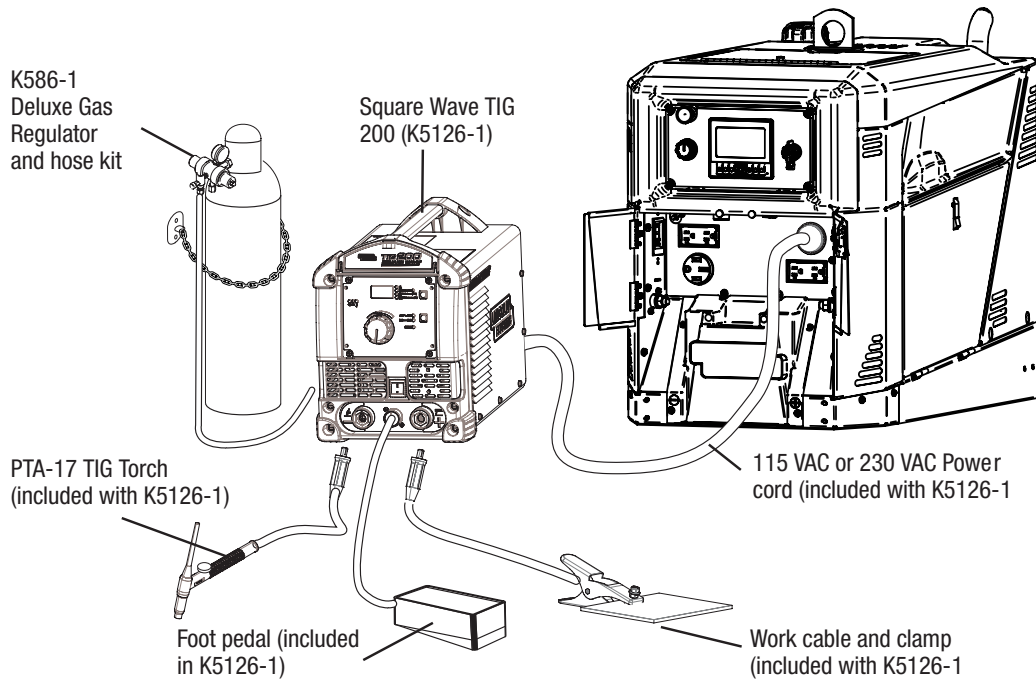

Figure 11 : AC TIG Setup with High Frequency

FUEL - USE GASOLINE FUEL ONLY**⚠ WARNING****GASOLINE EXPLOSION**

- Stop engine while fueling.
- Do not smoke when fueling
- Keep sparks and flame away from tank
- Do not leave unattended while fueling
- Wipe up spilled fuel and allow fumes to clear before starting engine.
- Do not overfill tank, fuel expansion may cause overflow.
- Replace the fuel cap only with proper cap from Lincoln Electric.

Fill the fuel tank with clean, fresh, lead-free gasoline. Do not top off tank. Be sure to leave filler neck empty to allow room for expansion.

To check fuel level, turn Engine Control Switch to "AUTO". Use only the proper fuel cap from Lincoln Electric. The cap has an internal safety vent to prevent damage to the machine.

⚠ WARNING

Overfilling tank can lead to engine damage.

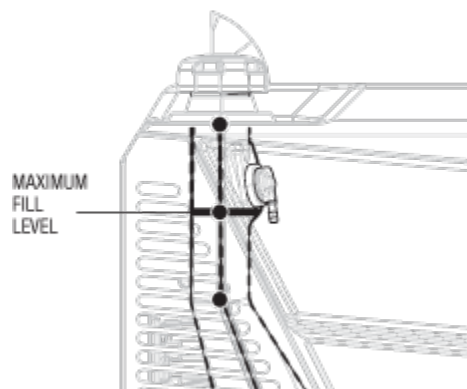
**OIL**

The welder is shipped with the engine crankcase filled with SAE 10W-30 oil. Check the oil level with the machine on a level surface before starting the engine. If it is not up to the full mark on the dip stick, add oil as required. Make certain that the oil filler cap is tightened securely. Refer to the engine Owner's Manual for specific oil recommendations.

SPARK ARRESTOR

CAUTION



An incorrect arrestor may lead to damage to the engine or adversely affect performance.

Some federal, state or local laws may require that gasoline or diesel engines be equipped with exhaust spark arrestors when they are operated in certain locations where unarrested sparks may present a fire hazard. The standard muffler included with this welder does not qualify as a spark arrestor. When required by local regulations, a suitable spark arrestor, such as the Kxxx must be installed and properly maintained.

MACHINE GROUNDING

Because this portable engine driven welder creates its own power, it is not necessary to connect its frame to an earth ground, unless the machine is connected to premises wiring (home, shop, etc.).

WARNING



To prevent dangerous electric shock, other equipment to which this engine driven welder supplies power must:

Be grounded to the frame of the welder using a grounded type plug or be double insulated.

Do not ground the machine to a pipe that carries explosive or combustible material.

When this welder is mounted on a truck or trailer, its frame must be securely connected to the metal frame of the vehicle. When this engine driven welder is connected to premises wiring such as that in a home or shop, its frame must be connected to the system earth ground. See further connection instructions in the section entitled "Standby Power Connections" as well as the article on grounding in the latest National Electrical Code and the local codes.

In general, if the machine is to be grounded, it should be connected with a #8 or larger copper wire to a solid earth ground such as a metal ground stake going into the ground for at least 10 Feet or to the metal framework of a building which has been effectively grounded.

The National Electric Code lists a number of alternate means of grounding electrical equipment. A machine grounding stud marked with the symbol is provided on the front of the welder.

AUXILIARY POWER**⚠ CAUTION**

An electric shock can result in serious injury or death.

Always perform the GFCI test before using the generator. If the GFCI system fails the test, the machine must be repaired by an authorized service center

Due to the risk of power interruption, do not power life support equipment from this machine.

Unplug accessories and tools before attempting service.

Close the front service doors protecting the receptacles when operating the machine.

Do not test or reset the GFCI while at idle speed.

If the LED blinks, stop using the GFCI receptacle and have it replaced by an authorized service center.

Long extension cords or cords with poor insulation may allow enough leakage current to trip the GFCI.

When set to high idle, the output frequency is controlled to 57 to 63 Hz under steady state conditions. If the machine is set to AUTO, the output frequency may drop to 40 Hz with a lower voltage. Verify equipment connected to the Ranger is compatible with the frequency and voltage.

For equipment affected by momentary voltage fluctuations, install a plug-in surge suppressor on the receptacles feeding the equipment.

The Lincoln Electric Company is not responsible for any damage to electrical components improperly connected to this product.

Overload operation:

Never exceed the rated load when it is running continuously. Before connecting and operating the Ranger, calculate the electrical power (in Watts) required by the devices to be powered. This electrical power rating is usually found on manufacturer's plate on motors, appliances and power supplies. The sum total power required by these devices should not exceed the nominal power of the Ranger.

Most motors require more than their rated wattage for start-up.

Devices with large start-up power demands may not allow the engine to reach normal operating rpm when the machine is set to AUTO. Turn the OFF/AUTO/HIGH/START switch to HIGH.

In the event that the combined weld + auxiliary power load exceeds the machine's capability, the welding circuit will continue to drive as much power as possible without causing damage to any components. Continued operation in an overload state will bog and stall the engine. Overloading just the auxiliary power circuits will cause the circuit breakers to trip.

INSTALLATION

OPERATION

SAFETY PRECAUTIONS

Read and understand this entire section before operating your RANGER 260MPX & 330MPX.

WARNING



Do not attempt to use this equipment until you have thoroughly read the engine manufacturer's manual supplied with your welder. It includes important safety precautions, detailed engine starting, operating and maintenance instructions, and parts lists.

WARNING



ELECTRIC SHOCK can kill.
Do not touch electrically live parts or electrode with skin or wet clothing.
Insulate yourself from work and ground.
Always wear dry insulating gloves.

WARNING



ENGINE EXHAUST can kill.
Use in open, well ventilated areas or vent exhaust outside.
Do not stack anything near the engine.

WARNING





MOVING PARTS can injure.
Do not operate with doors open or guards off.
Stop engine before servicing.
Keep away from moving parts.

The serviceability of a product or structure utilizing the welding modes is and must be the sole responsibility of the builder/user. Many variables beyond the control of The Lincoln Electric Company affect the results obtained in applying these programs. These variables include, but are not limited to, welding procedure, plate chemistry and temperature, weldment design, fabrication methods and service requirements. The available range of a welding mode may not be suitable for all applications, and the builder/user is and must be solely responsible for welding mode selection.

GRAPHIC SYMBOLS

The following graphics appear on the Ranger or in the manual.

Table 2 :GRAPHIC SYMBOLS

	WARNING OR CAUTION		HOT SURFACE		EARTH GROUND
	INSTRUCTIONS		FIRE OR EXPLOSION		CIRCUIT BREAKER
	FUMES AND GASES		BATTERY EXPLOSION	A	WELDING AMPERAGE
	EXPLOSION		BATTERY ACID	V	WELDING VOLTAGE
	ARC RAYS		SYSTEM FACTORY RESET		WIRE FEED SPEED
	MOVING PARTS		TEMPERATURE		ARC LENGTH
	FALLING EQUIPMENT	+	POSITIVE OUTPUT		3 PHASE ALTERNATOR
	ELECTRIC SHOCK	-	NEGATIVE OUTPUT		DIRECT CURRENT
U0	OPEN CIRCUIT VOLTAGE		SMAW WELDING		CHOKE
I2	OUTPUT CURRENT		GMAW/FCAW WELDING		STOP
U2	OUTPUT VOLTAGE		GTAW WELDING		AUTO IDLE
X	DUTY CYCLE		SPOOL GUN		HIGH IDLE
	HOME		CARBON ARC GOUGING		START
	REMOTE		DOWNHILL PIPE WELDING		SELECT

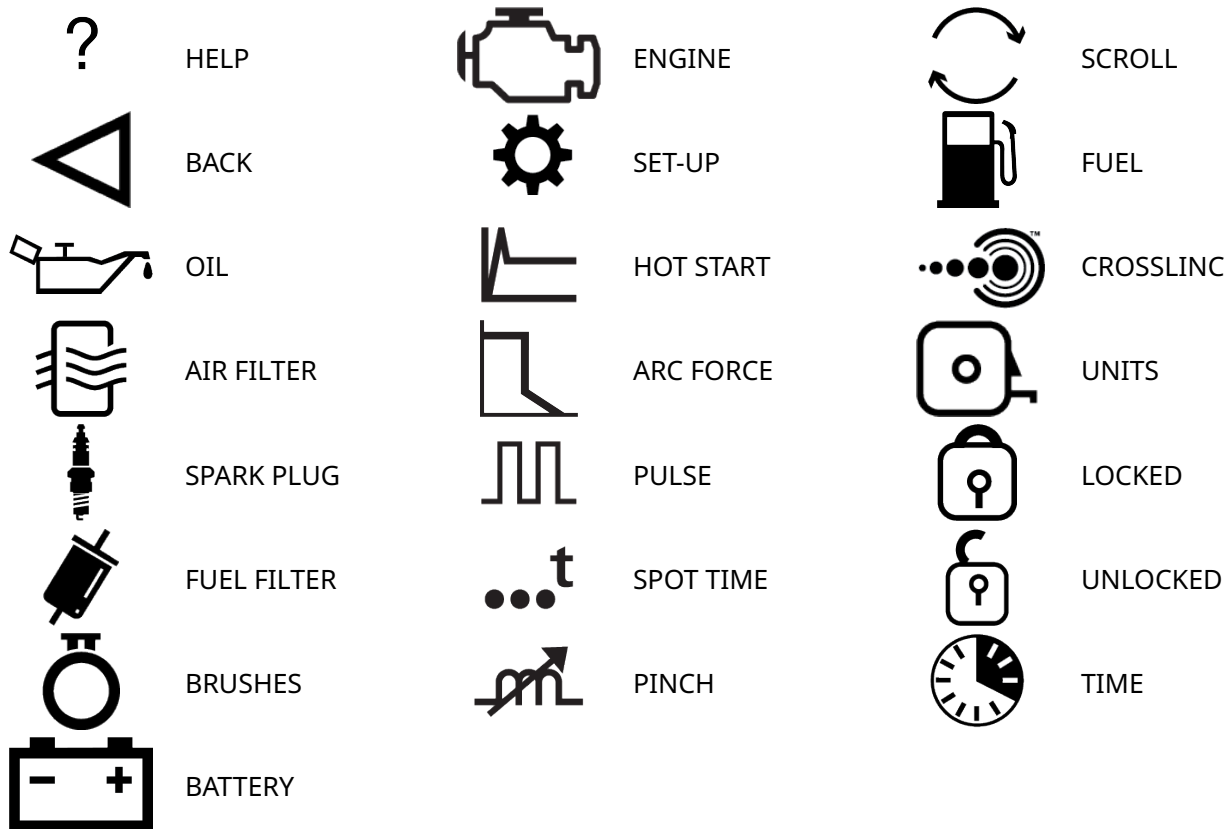

CASE FRONT CONTROLS

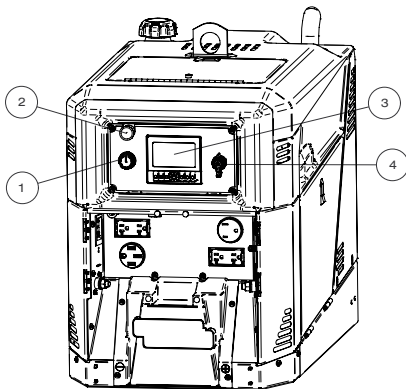

- 1. KNOB AND PUSH BUTTON** - Rotate the knob to adjust values shown on the display. Push the knob to select the value.
- 2. CHOKE** - Pull the choke out when starting the engine, and then slowly push in once the engine has started. The choke is not present on EFI machines.
- 3. DISPLAY** - Shows information about the RANGER 260MPX & 330MPX operation.
- 4. ENGINE CONTROL SWITCH** - The engine control switch has four positions:

OFF: Turns off the RANGER 260MPX & 330MPX, all electronics and the engine.

AUTO: When either a welding load or auxiliary power load is present, the engine will operate at full speed (3600 rpm). About 12 seconds after the load is removed, the engine slows to idle speed (2500 rpm).

In AUTO idle, the engine may switch from idle speed to high idle without a load being applied. This keeps the engine operating at an optimum air/fuel ratio and may occur when at high altitude and hot ambient temperatures.

HIGH IDLE: The engine always operates at full speed (3600 rpm).

START: Used to start the engine. Place the engine control switch in either AUTO or HIGH IDLE once the engine has started.

WELDING

The RANGER 260MPX & 330MPX are multi-process machines capable of welding many materials. Available weld modes and output ranges are:

	RANGER 260 MPX	RANGER 330MPX RANGER 330MPX EFI
STICK	35 TO 260A	35 TO 330A
SPOOL GUN	14 TO 40V	14 TO 40V
	50 TO 750 IPM	50 TO 750 IPM
CV (MIG)	14 TO 40V	14 TO 40V
CV (FCAW-SS)	14 TO 40V	14 TO 40V
TIG	25 TO 260A	25 TO 330A
GOUGE	N/A	35 TO 330A
PIPE	N/A	35 TO 330A

If desired, weld modes can be turned off in the main menu so only commonly used weld modes are shown. See setting "Active Weld modes" in the set-up menu.

DISPLAY OPERATION

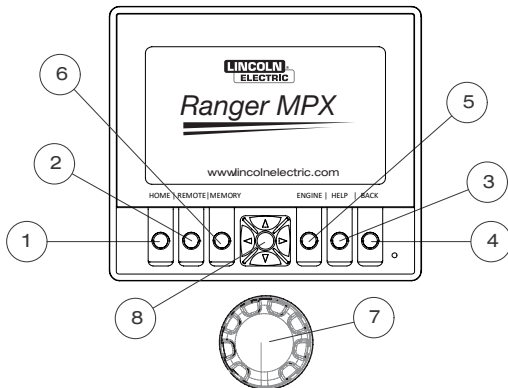

1. **HOME** - Brings up the home screen (main menu).
2. **REMOTE CONTROL** - Toggles the remote control ON / OFF.
3. **HELP** - Displays additional information describing the function.
4. **BACK** - Goes back to the previous screen.
5. **ENGINE SERVICE SCREEN** - takes operator directly to the engine service screen.
6. **MEMORY** - operator can store their favorite weld settings for easy call back.
7. **KNOB** - rotate adjusts values, push confirms the selected value or choice.
8. **ARROW KEYS** - adjust values with left, right, up, and down keys. push center to confirm the selected value or choice.

Note: When RANGER 260MPX & 330MPX machines are first started, they will return to the screen that was shown when the machine was turned off.

HOME SCREEN

Pressing the Home button displays the home menu. Rotate the knob to select the desired weld mode, or choose engine options or set-up menu. Push the button to make the selection.

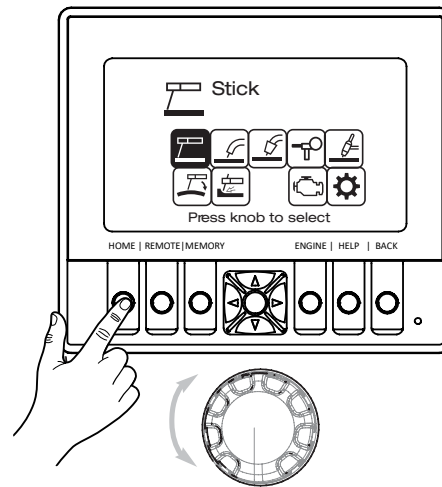

WELD SCREENS, MANUAL ENTRY

Manual entry operates like a traditional welding machine. Simply set the desired preset amperage or voltage and begin to weld. The "Preset" screen appears when welding is not active. It shows the amount of fuel on the left hand side; the weld mode in the lower left hand corner; the preset value in the middle; and the weld output status in the upper right corner.

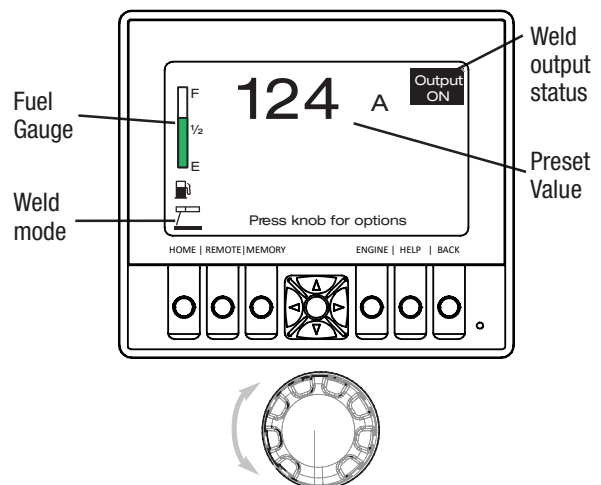

Once welding occurs, the screen changes to show the actual amperage and voltage.

When welding stops, the amperage and voltage numbers will flash for 7 seconds. The display will then switch back to the preset screen.

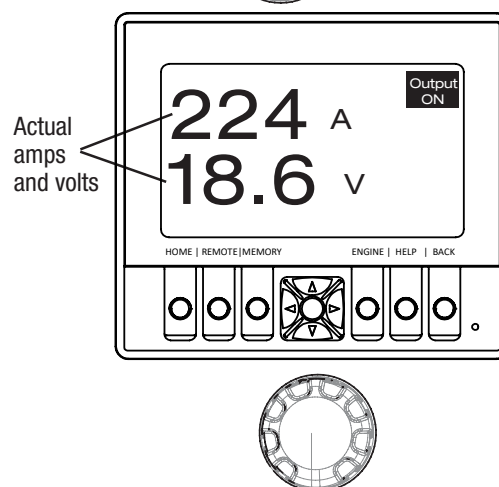

WELD SCREENS, READY.SET.WELD.

Ready.Set.Weld. recommends ranges for a given weld procedure. To start the Ready.Set.Weld, press the Help button when in a preset welding screen.

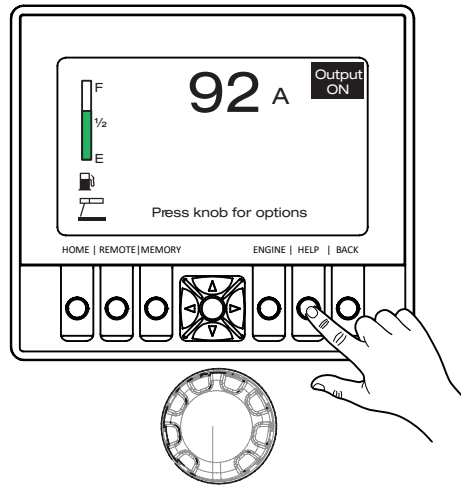

Rotate the knob to choose the electrode type. Press the knob to select. To turn off Ready.Set.Weld, select "Manual Entry".

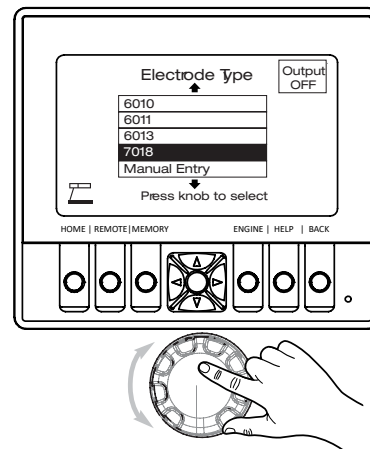

Next, select the electrode diameter. Press the knob to select.

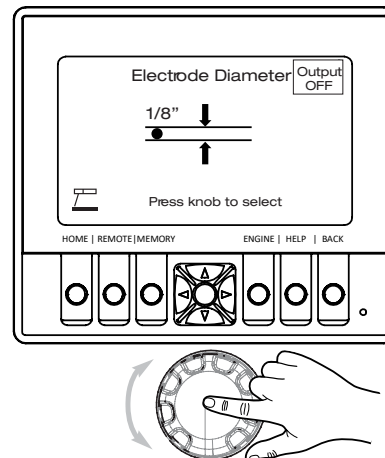

Select the material thickness. Press the knob to select.

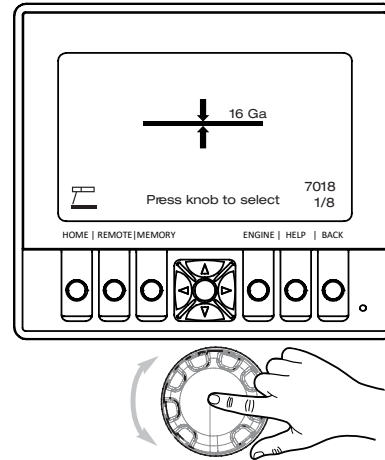

Connect the electrode and work cables as shown in the diagram. When complete, press the knob to turn the output ON and start welding.

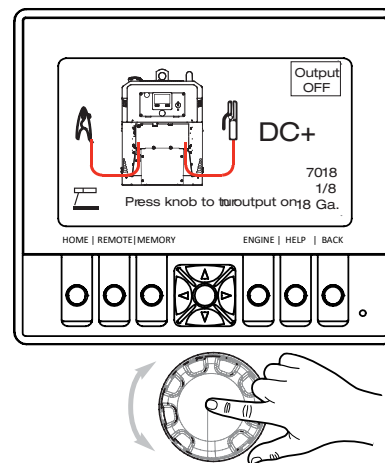

CROSSLINC

CrossLinc provides the benefits of remote control without a cable. The accessory or wire feeder talks to the power source by sending signal through the electrode cable.

To start CrossLinc, simply connect the weld cables and sense lead per the CrossLinc device's instructions. Select the desired weld mode with the Ranger. When weld output is ON, the CrossLinc device will automatically link to the Ranger. The CrossLinc icon will appear on the screen to show active communication.

When CrossLinc is active, the remote control is disabled.

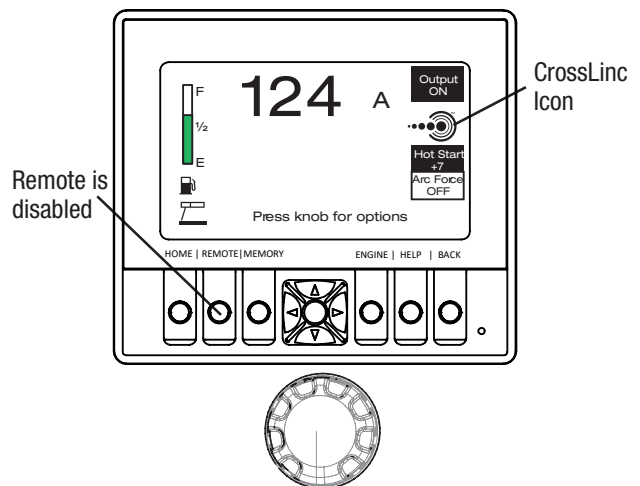

REMOTE CONTROL

All weld modes support using a remote control like K857-1. Plug the remote into the 6 pin connector on the front of the machine.

Press the remote button on the display to toggle between control at the remote and control at the knob on the machine. The remote button does not function when welding is occurring.

When a CrossLinc device is connected, the remote control is ignored. Use the CrossLinc device to remotely set values.

When the remote is enabled, a bar will appear underneath the preset value showing the remote range. The standard range allows the remote to adjust from the minimum to the maximum value of the machine.

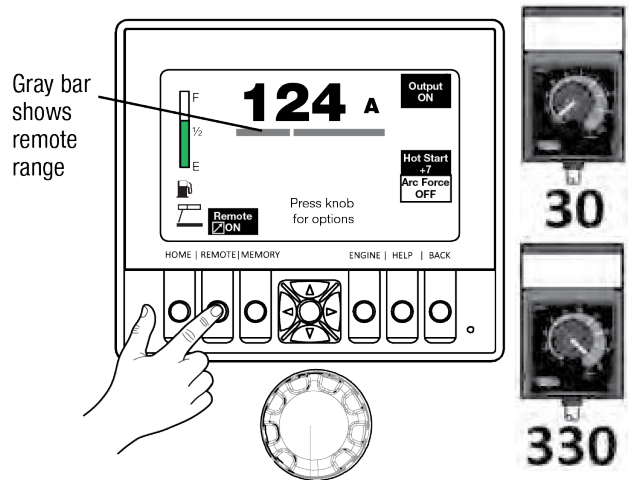

Frequently the entire output range is not required for a weld procedure. To limit the range of the remote, press the knob to enter the Options screen and select Remote Control Range.

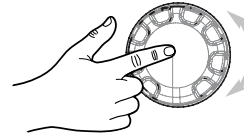
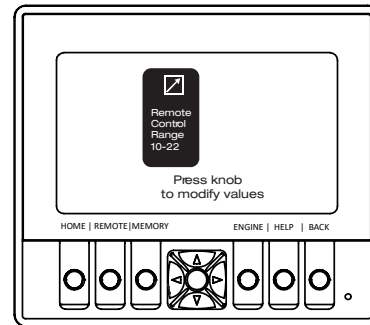

Rotate the knob to adjust the maximum value for the remote control. The gray bar will change size to show the usable range. The restricted range is shown as a thin red bar. Press the knob to select the value.

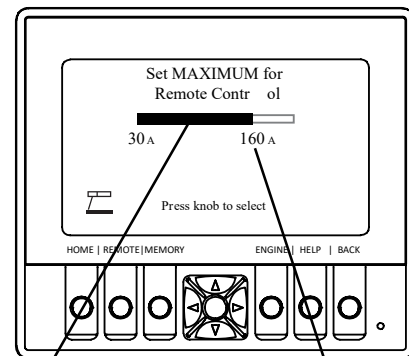

The usable range is shown as a thick grey bar. The restricted range is shown as a thin red bar.

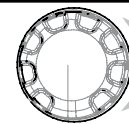

Rotate the knob to adjust the minimum value for the remote control. The gray bar will change size to show the usable range. The restricted range is shown as a thin red bar. Press the knob to select the value.

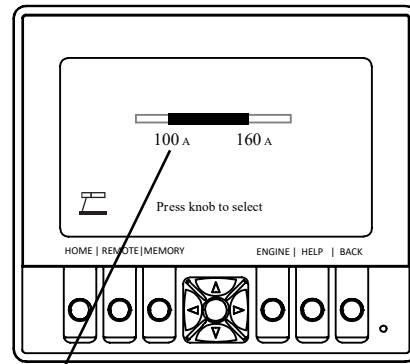

Minimum value

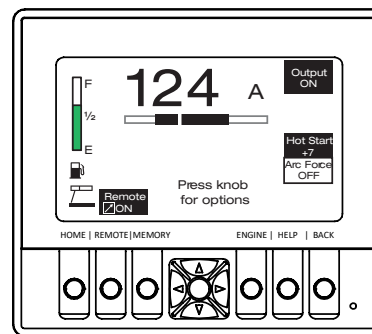
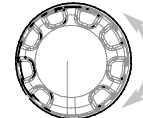

100



160

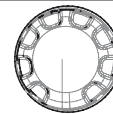

With the new settings, the sensitivity of the remote is increased.

Thicker bar shows remote range. Thin bars show total range. Red and green sections show recommended range.

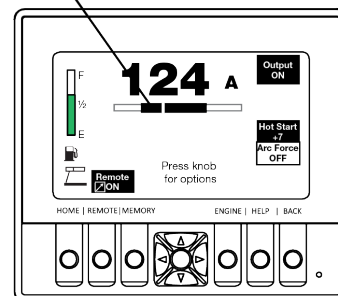

100



160

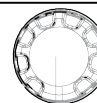

SPOOL GUN OPTIONS (*RANGER 330MPX ONLY)

Synergic Control:

The spool gun may be set in either “normal” control or “synergic” control. Synergic mode automatically adjusts the voltage when the wire feed speed is changed.

To activate synergic control, press the knob for options when in the spool gun mode. Rotate the knob to choose “Synergic Control” and then press the knob.

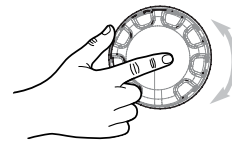
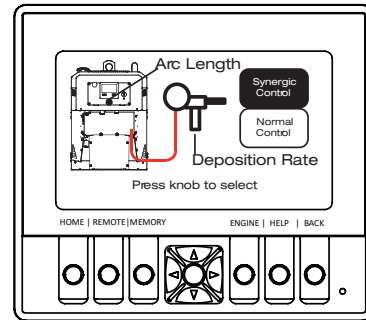
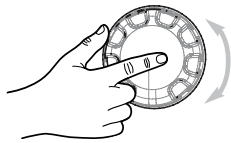
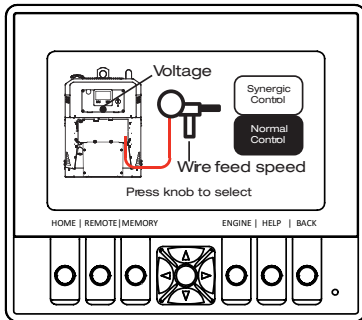
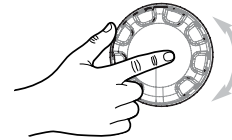
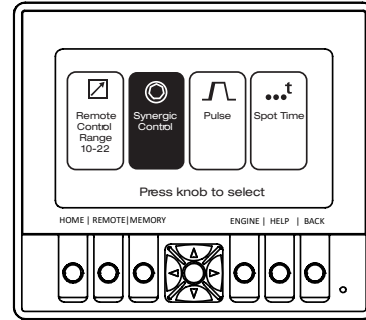

Rotate the knob to change between normal control and synergic control. Press the knob to select

SPOOL GUN PULSE (*RANGER 330MPX ONLY)

Spool Gun Pulse is only available when an aluminum wire is selected with the Ready.Set.Weld menu.

Activating Spool Gun Pulse toggles both the voltage and wire feed speed between a peak and a low level. It is useful for lower heat input welding and creating the appearance of “stacked dimes” in aluminum.

To activate spool gun pulse, the Ready.Set.Weld entry must be set for an aluminum electrode.

Press the knob for options when in the spool gun mode. Rotate the knob to choose “Pulse” and then press the knob. Adjust the pulse frequency from OFF to 2.5 Hz.

The voltage and wire feed speed values represent peak values. The lower settings are automatically

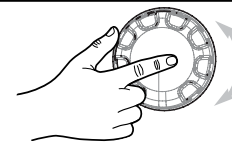
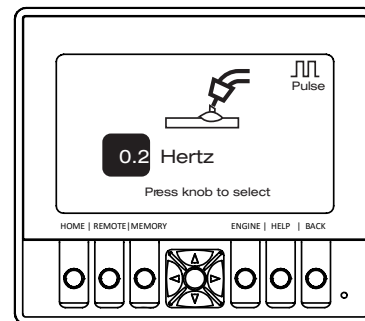
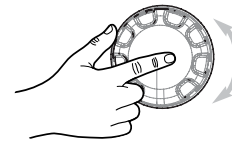
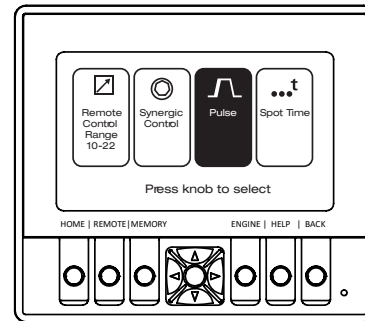

SPOT TIME (RANGER 330MPX ONLY)

Spot Time is useful for making multiple welds of a similar size. Popular applications are when welding on thin material to control heat input, and to make consistent sized tack welds. When spot time is enabled, welding continues for the period of time chosen, as long as the trigger is pulled. Welding stops when the time is exceeded, even if the trigger remains pulled. Release the trigger and pull again to make another weld.

To activate spot time, press the knob for options when in the spool gun mode. Rotate the knob to choose “Spot Time” and then press the knob.

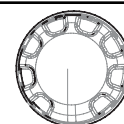
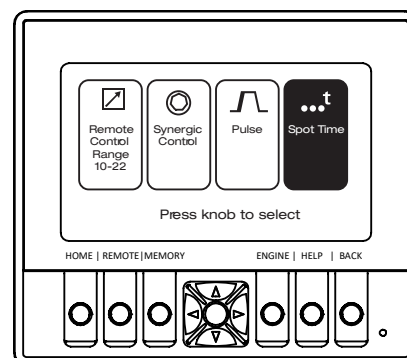

OPERATION

When the spot time screen appears, rotate the knob to change the time, and press the knob to select.

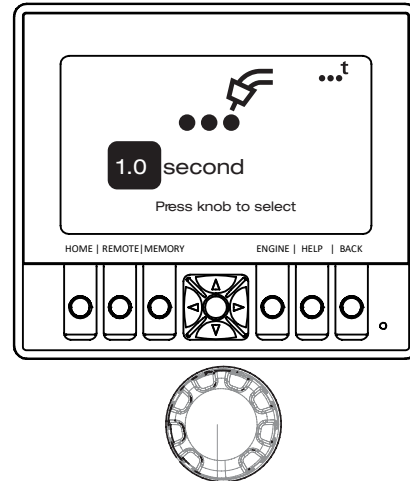

WELD SETTING MEMORY

The RANGER 260MPX & 330MPX is capable of storing a single weld setting. To save a desired weld setting (while in the desired weld screen), press and hold the memory button for 5 seconds. A confirmation will appear on screen indicating it successfully saved. The Memory button can then be pressed in any screen to recall the settings.

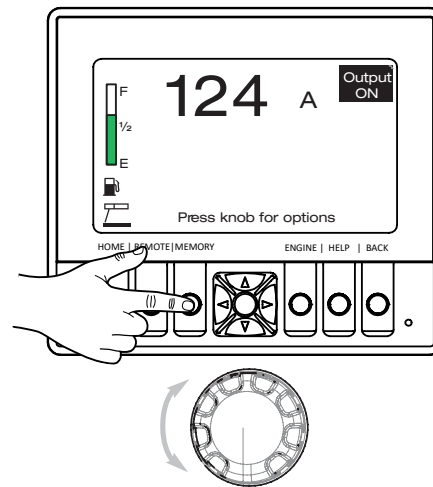

ARC OPTIONS

The Ranger® 330MPX and 330MPX EFI offers options to fine tune the arc. The options available depend upon the weld mode. **Arc Options are not available on the Ranger 260MPX.**

	HOT START	ARC FORCE	PINCH	PULSE (Hz)
STICK	0 TO 10	-10 TO 10		
SPOOL GUN				0 TO 2.5
CV (MIG)			-10 TO 10	
CV (FCAW-SS)			-10 TO 10	
TIG				0 TO 20
GOUGE				
PIPE		-10 TO 10		

HOT START - Hot Start is a temporary increase of the output current during the start of a weld. This helps ignite the arc quickly and reliably. Hot Start provides excellent arc ignition without the electrode sticking and avoiding any metallurgical defect in the weld.



ARC FORCE - Arc Force is a temporary increase in current to clear short circuits between the electrode and the workpiece. Lower values will provide less short circuit current and a softer arc. Higher settings will provide a higher short circuit current, a more forceful arc and possibly more spatter.

PINCH - Pinch controls the arc characteristics when short-arc welding. Increasing Pinch greater than 0.0 results in a crisper arc (more spatter) while decreasing the Pinch Control to less than 0.0 provides a softer arc (less spatter).

PULSE, SPOOL GUN - Pulse welding with a spool gun helps to lower heat input and create an attractive weld. Set the frequency of the pulsing to achieve the desired effect. Slower pulsing results in larger "stacked dimes" while higher frequency helps to wet out the puddle. When pulsing, the preset wire feed speed and voltage are used for the peak values.

PULSE, TIG - Use pulse TIG welding to help minimize burn through on thin materials. It can help to increase travel speed and result in a smaller bead width. Lower heat input may lessen warpage of parts, especially stainless steel materials. The Pulse TIG feature has a single knob control which sets the Pulse Frequency over the range of 0.1-20 Hz (0.1-20 pulses per second). Setting the frequency to "off" shuts off Pulse TIG. The pulse setting automatically regulates the output current between the peak amperage, set by the max output control and the remote amptrol (if used), and a background amperage setting that is equal to 50% of the peak amperage setting. The Peak Pulse % on-time is fixed at 50%.

ENGINE STATUS SCREEN

 WARNING	
	<p>Have qualified personnel do all maintenance and troubleshooting work.</p> <p>Turn the engine off before working inside the machine or servicing the engine.</p> <p>Remove guards only when necessary to perform maintenance and replace them when the maintenance requiring their removal is complete. If guards are missing from the machine, obtain replacements from a Lincoln Distributor (See Operating Manual Parts List.)</p>

Read the Safety Precautions in the front of this manual and in the Engine Owner's Manual before working on this machine.

Keep all equipment safety guards, covers and devices in position and in good repair. Keep hands, clothing and tools away from gears, fans, and all other moving parts when

The Engine Status screen provides information about the engine servicing and operation.

The Engine Status screen can be accessed at any time using the Engine button on the display.

OPERATION

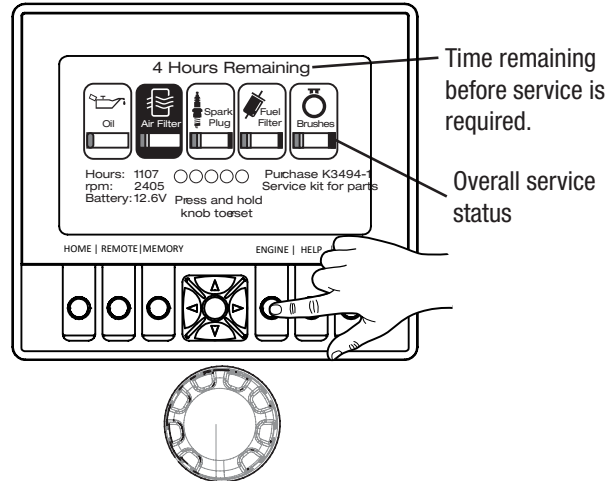

Five parts of the engine are monitored for service: Oil and oil filter, Air Filter, Spark Plug and Brushes. To view detailed information about an item, rotate the knob until the item is highlighted in red. The top of the screen displays the number of hours remaining until service is required for the selected item.

The red/yellow/green bars for each item indicate how much time is left.

- Green = Normal operation
- Yellow = Service is required soon
- Red = Service is overdue

After service has been performed on an item, press and hold the knob for 5 second to reset the service interval timer.

FUEL CONSUMPTION CURVE

	GALS / HR	LITERS / HR	RUN TIME FOR 11 GALLONS
WELDING 330 AMPS @ 28 VOLTS (330MPX ONLY)	1.6	6.07	6.9 HOURS
WELDING 260 AMPS @ 26 VOLTS	1.32	4.99	8.3 HOURS
AUXILIARY POWER 10,000 WATTS	1.56	5.92	7.0 HOURS
HIGH IDLE, NO LOAD	0.84	3.18	13.1 HOURS
LOW IDLE, NO LOAD	0.55	2.07	20.1 HOURS

BATTERY SAVER

If the OFF/IDLE/RUN/START switch is in the IDLE or RUN position and the engine is not running, after 2 minutes without any activity on the display the Ranger will enter a sleep mode prevent a dead battery. To bring the machine out of sleep mode, move the OFF/IDLE/RUN/START switch to OFF for 10 seconds and then restart the machine.

AUXILIARY POWER

⚠ WARNING



An electric shock can result in serious injury or death.

Always perform the GFCI test before using the generator. If the GFCI system fails the test, the machine must be repaired by an authorized service center.

If the GFCI fails to trip when the test button is pressed (“ON” light does not go off) or “STATUS” light is RED) or fails to reset (“ON” light does not go on or “STATUS” light is blinking) the device is inoperative and should be replaced immediately.

If the GFCI tests properly without any appliance connected to it but trips each time an appliance is connected to it, the appliance has a ground fault and needs to be repaired or replaced. **DO NOT USE THE APPLIANCE IF THIS CONDITION OCCURS: A REAL SHOCK HAZARD MAY EXIST.**

Due to the risk of power interruption, do not power life support equipment from this machine.

GFCI’s do not protect against short circuits or overloads.

Unplug accessories and tools before attempting service.

Close the front service doors protecting the receptacles when operating the machine.

Do not test or reset the GFCI while at idle speed.

If the LED blinks, stop using the GFCI receptacle and have it replaced by an authorized service center.

Long extension cords or cords with poor insulation may allow enough leakage current to trip the GFCI.

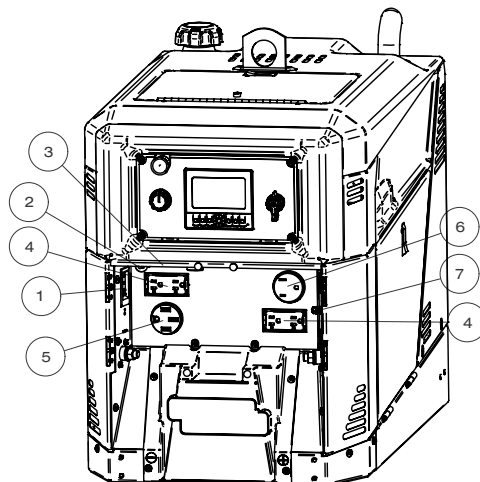

Item No.	Item Name	Item Description
1	GFCI MODULE	The GFCI module protects the (2) 120 VAC duplex receptacles. Two different types of modules are used in the Rangers.
2	50 AMP CIRCUIT BREAKER	

OPERATION

Item No.	Item Name	Item Description
3	20 AMP CIRCUIT BREAKER	Protects the GFCI and (2) 120 VAC duplexes from overload. If the circuit breaker opens, the receptacles will not work. Press to reset. If it continues to remain open, contact an authorized Lincoln service shop.
4	120 VAC DUPLEX	The 120 VAC duplex receptacles should only be used with three wire grounded type plugs or approved double insulated tools with two wire plugs.
5	120/240 VAC 14-50R RECEPT.	
6	240 VAC 6-50R RECEPT.	
7	NEUTRAL STUD	If the machine is to be grounded, use a AWG #8 copper wire or larger to a solid earth ground. Refer to local codes and the U.S. National Electrical Code.

GFCI MODULE

The GFCI module protects the (2) 120 VAC duplex receptacles. Two different types of modules are used in the Rangers.

Machines manufactured approximately September 2021 or earlier

The GFCI is an auto reset GFCI. It is identified by the "ON" LED located below the buttons.

- Auto Reset: Immediately supplies power to the load when power is applied to the line.
- "ON" LED illuminates red when the load has power.

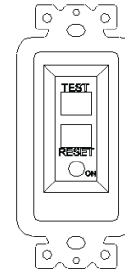

To test this GFCI, press the "TEST" button. The "ON" red LED should turn off. Then press the "RESET" button. The "ON" red LED should turn on. If the "ON" red LED does not turn off and on as indicated, the GFCI failed the test and should be replaced.

Machines manufactured approximately October 2021 or later

The GFCI is an auto reset, self-testing GFCI. It is identified by the "STATUS" LED located above the buttons.

- Auto Reset: Immediately supplies power to the load when power is applied to the line.
- "STATUS" LED illuminates Green when the GFCI is functioning properly.
- "STATUS" LED illuminates Red when the GFCI has "tripped". Press the reset button.
- "STATUS" LED illuminates flashing Red when the GFCI has failed and needs replaced.

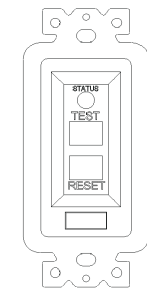

While this GFCI has a self-testing feature, to manually test this GFCI, press the "TEST" button. The "STATUS" LED should turn red. Then press the "RESET" button. The "STATUS" LED should turn green. If the "STATUS" LED does not turn red and green as indicated, or flashes red, the GFCI failed the test and should be replaced."

AUXILIARY POWER OPERATION

Combined continuous output of all receptacles is limited to 9.5kW for the Ranger 260MPX and 10.0kW for the Ranger 330MPX. The current rating of any plug used with a receptacle must be at least equal to the rating of the receptacle.

Output voltage is within $\pm 5\%$ at all loads up to rated capacity. When set to high idle, the output frequency is controlled to 57 to 63 Hz under steady state conditions. If the machine is set to AUTO, the output frequency may drop to 40 Hz with a lower voltage. Verify equipment connected to the Ranger is compatible with the frequency and voltage.

For equipment affected by momentary voltage fluctuations, install a plug-in surge suppressor on the receptacles feeding the equipment.

The Lincoln Electric Company is not responsible for any damage to electrical components improperly connected to this product.

OVERLOAD PROTECTION

Never exceed the rated load when it is running continuously. Before connecting and operating the Ranger, calculate the electrical power (in Watts) required by the devices to be powered. This electrical power rating is usually found on manufacturer's plate on motors, appliances and power supplies. The sum total power required by these devices should not exceed the nominal power of the Ranger.

Most motors require more than their rated wattage for start-up.

Devices with large start-up power demands may not allow the engine to reach normal operating rpm when the machine is set to AUTO. Turn the OFF/AUTO/HIGH/START switch to HIGH.

In the event that the combined weld + auxiliary power load exceeds the machine's capability, the welding circuit will continue to drive as much power as possible without causing damage to any components. Continued operation in an overload state will bog and stall the engine. Overloading just the auxiliary power circuits will cause the circuit breakers to trip.

SIMULTANEOUS WELD AND POWER TABLE

SIMULTANEOUS WELDING AND POWER LOADS			
WELDING OUTPUT - AMPS	PERMISSIBLE POWER - WATTS (UNITY POWER FACTOR)	PERMISSIBLE AUXILIARY CURRENT IN - AMPS	
		120VAC*	240VAC
0	10,000	84**	42
100	7,400	62**	31
150	5,800	48**	24
200	3,900	32**	16
250	2,400	20	10
300	900	8	4
330	0	0	0
	*	120VAC RECEPTACLES LIMITED TO 20 AMPS	
	**	NOT TO EXCEED 50A PER 120VAC BRANCH CIRCUIT WHEN SPLITTING THE 240VAC OUTLET	

SET-UP MENU

The set-up allows for customization of the Ranger. The supervisor PIN code will be required to access the Set-up menu if it is active.

Options available in the Set-up menu are:

- Language selection
- Units
- Restore Factory Settings
- Security
- Engine Service Time
- Weld Mode Select
- Clock
- Display Brightness
- Spool Gun Calibration
- Diagnostic information
- Fuel Purge

Language

Select from English (default), Spanish or French.

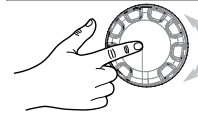
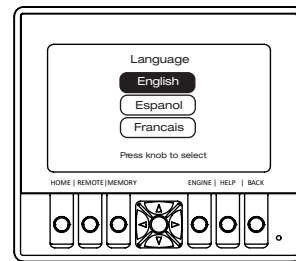

Units

Select from Imperial (default) or metric units. Imperial units show dimensions in inches and fractions. Metric units show dimension in millimeters.

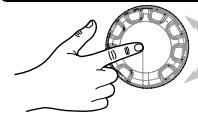
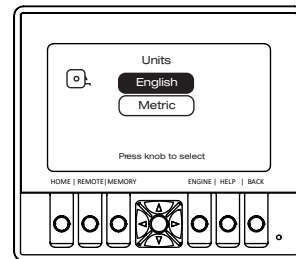

Restore Factory Settings

Restoring factory settings resets all weld modes to original values, resets the remote control values, clears the Ready.Set.Weld. settings, clears the security PINs, resets calibration of the spool gun, sets the language to English and units to Imperial.

Press and hold the knob 5 seconds to confirm restore factory settings.

SECURITY

The Ranger has two levels of security – Operator and Supervisor.

OPERATOR SECURITY – When the Operator PIN (personal identification number) is enabled, the engine will not start until the proper PIN has been entered.

SUPERVISOR SECURITY – When the Supervisor PIN is enabled, the Set-up menu and Engine menu are restricted and cannot be accessed until the Supervisor PIN is entered.

A time delay may be enabled for the operator PIN. This may be useful if the machine has been equipped with an after-market remote start. The operator PIN is entered at the beginning of the day, and then is not required for the selected time period.

DO NOT FORGET THE PIN! The PIN may only be reset by a Lincoln Authorized Service Shop.

Once in the set-up menu, select the PIN. Rotate the knob to choose either Operator PIN or Supervisor PIN and then press the button to select.

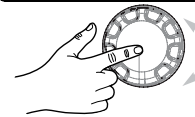
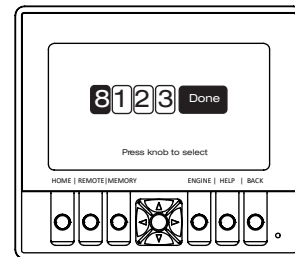
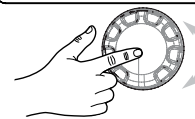
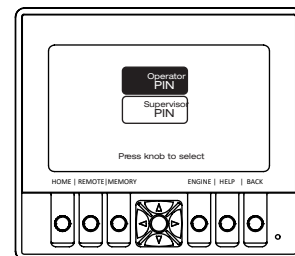

Enter the current PIN. Rotate the knob to adjust the values and press the knob to select and advance to the next number. Press the back button to go to a previous number.

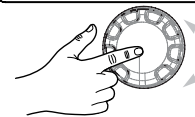
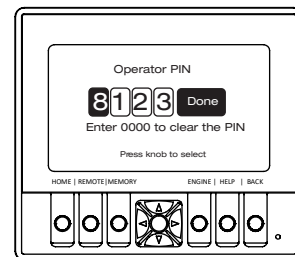

Enter the new PIN.

OPERATION

The Operator PIN has the option of setting a time delay. Using a time delay may be useful when one person starts the Ranger at the beginning of the day, and other people weld with the machine throughout the day. The time delay allows the machine to be turned off and restarted during the specified period without requiring a PIN entry.

Press and hold the knob for 5 seconds to confirm entry of the PIN.

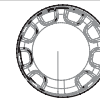
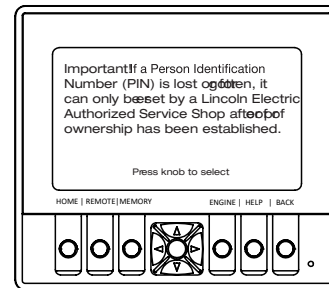
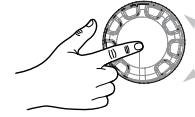
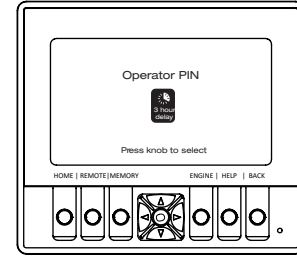

ENGINE SERVICE TIME (*CHOPPER SOFTWARE VERSION S32664-6 AND EARLIER)

When the Ranger is operated in severe conditions, the engine service alerts can be adjusted to appear more frequently. The factory setting is for alerts to occur when 10% of the service interval is remaining. The alert notification may be adjusted between 1 and 50% of the service time.

ITEM	RECOMMEND SERVICE INTERVAL	DEFAULT ALERT TIME	ALERT TIME RANGE
OIL AND OIL FILTER	100 HOURS	10 HOURS	1 - 50 HOURS
AIR FILTER	100 HOURS	10 HOURS	1 - 50 HOURS
SPARK PLUG	500 HOURS	50 HOURS	5 - 250 HOURS
FUEL FILTER	200 HOURS	20 HOURS	2 - 100 HOURS
BRUSHES	1000 HOURS	100 HOURS	10 - 500 HOURS

*Chopper software version S32664-7 and later

The intervals at which the engine maintenance alerts appear may be customized. For example, the oil change and filter alert may be customized to appear 2 hours before an oil change is due; or 24 hours before an oil change is due or turned off completely.

ITEM	RECOMMEND SERVICE INTERVAL	DEFAULT ALERT TIME	ALERT TIME RANGE
OIL AND OIL FILTER	100 HOURS	10 HOURS	OFF, 1 - 50 HOURS
AIR FILTER	100 HOURS	10 HOURS	OFF, 1 - 50 HOURS
SPARK PLUG	500 HOURS	50 HOURS	OFF, 5 - 250 HOURS
FUEL FILTER	200 HOURS	20 HOURS	OFF, 2 - 100 HOURS
BRUSHES	1000 HOURS	100 HOURS	OFF, 10 - 500 HOURS

To adjust the service intervals, rotate the knob to select the desired item and then press the knob.

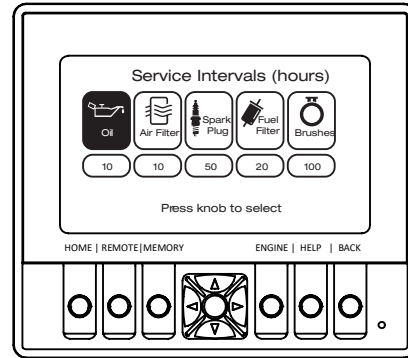

Rotate the knob to adjust the value and then press the knob to accept.

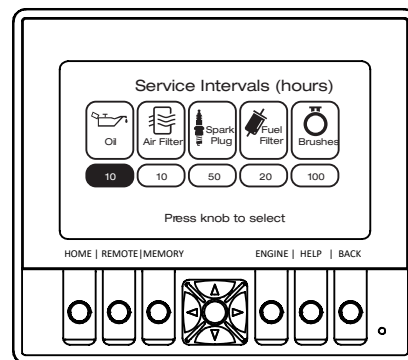

WELD MODE SELECT

The home menu may be customized to show only weld modes that are frequently used. Use the Weld Mode Select to choose which weld modes appear in the home menu.

Rotate the knob to select the weld mode to modify and then press the knob. Rotate the knob to make the weld mode Active or OFF and then press the knob.

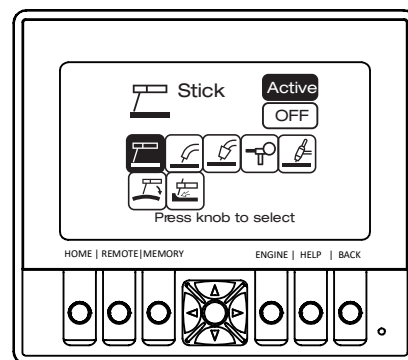

CLOCK

The RANGER 260MPX & 330MPX include an internal clock. The clock will require adjusting when traveling to different time zones or when Daylight Savings starts and ends.

Rotate the knob to adjust the hours and then press the knob.

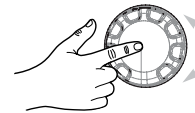
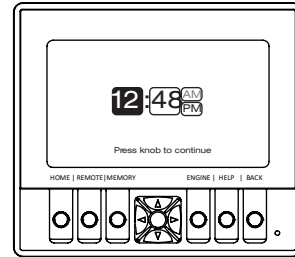

Rotate the knob to adjust the minutes and then press the knob.

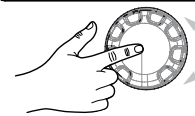
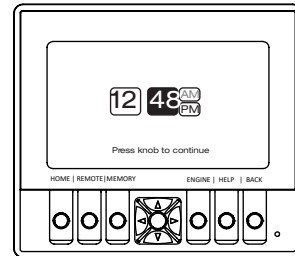

Rotate the knob to select AM or PM and then press the knob.

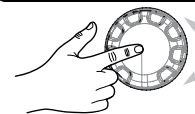
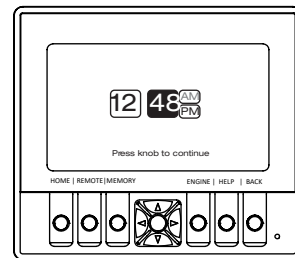

SPOOL GUN CALIBRATION

Spool gun calibration should be run when a new spool gun is attached to the Ranger. The calibration helps to compensate for differences between guns and will make the wire feed speed readings more accurate.

To calibrate a spool gun, start by loading the desired wire into the spool gun. Feed wire out of the gun and then trim it flush with the contact tip. Press the knob to continue.

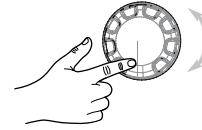
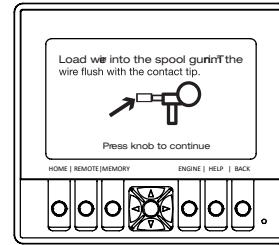

The calibration process will feed wire out of the spool gun for several seconds. Press the knob to start the wire feeding.

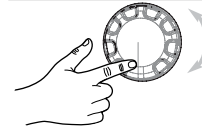
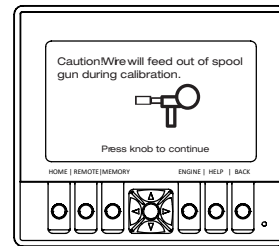

The screen will show wire feeding from the spool gun for about 5 seconds.

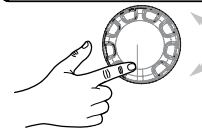
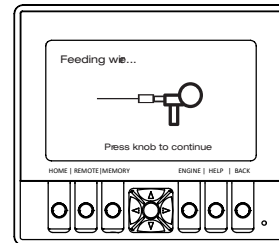

Rotate the knob to adjust the value shown on the screen to match the actual measured length of wire. Press the knob to complete spool gun calibration.

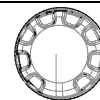
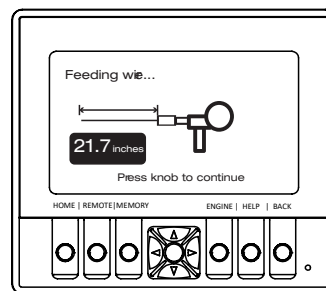

DIAGNOSTIC INFORMATION

The diagnostic screen lists information about part numbers and software installed in the machine. This may be useful for a service shop in the event repair is required.

FUEL PURGE

Storing welder for long periods without proper preparation may result in a machine that is difficult to start or runs rough because of residue build up carburetor. One method to reduce the residue build-up is to run the carburetor out of gas. When Fuel Purge is activated, the fuel pump is turned off. The Ranger will run for approximately a minute until the remaining gas in the carburetor is used up. The Ranger is then ready to turn off.

To run the Fuel Purge process, follow the instructions on the screen and press the knob to advance to the next step.

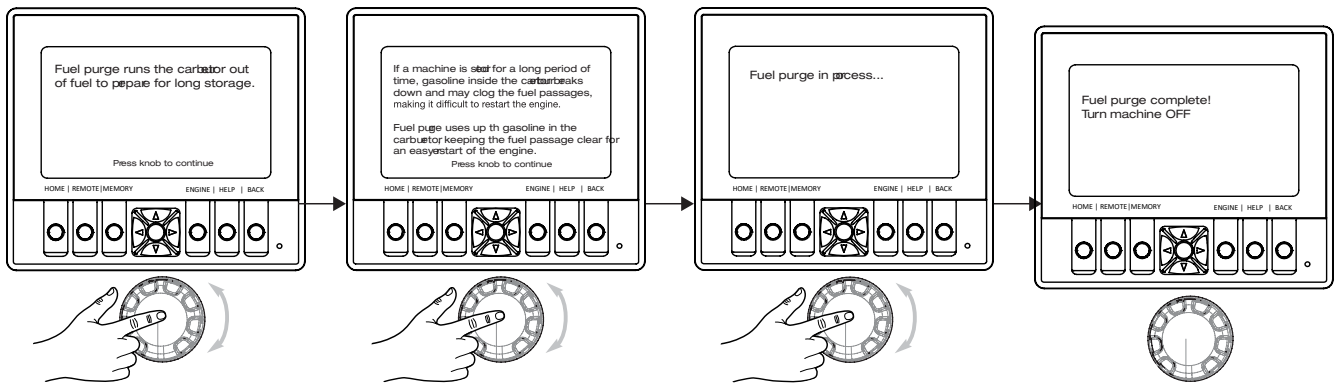

DEMO MODE

Note: Demo mode is pre-installed on machines with code number **12646** and codes **13011** and higher.

The demo mode is used when the Ranger's display will be shown for an extended period of time and the engine is not operating. During demo mode, the battery save function is disabled, the fuel pump is disabled and the engine maintenance/hour tracking functions will not increment.

Extended operation in the demo mode may drain the battery. Use an appropriately sized, listed battery charger when demo mode is being used for long periods of time.

To configure the Ranger for demo mode:

1. Disconnect the 6 pin engine harness to prevent the engine from cranking.



2. Turn the Stop/Auto Idle/High Idle/Start switch to **"Auto Idle"**.
3. Go to Set-Up Menu and select **"Demo Mode"**.

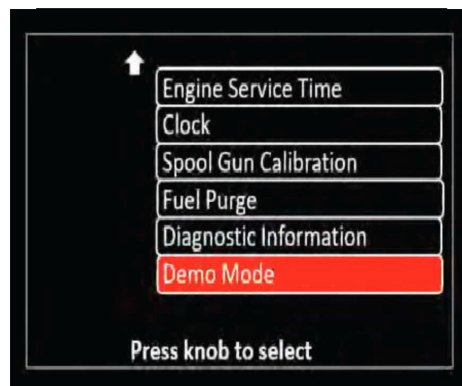

4. When demo mode is active, **"DEMO"** will flash in the lower right hand corner.

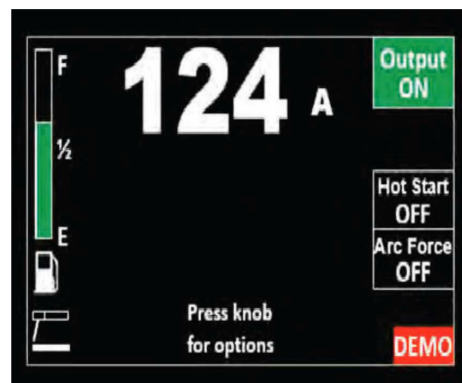

ACCESSORIES AND OPTIONS

ACCESSORIES

WIRE FEEDERS:	
K2999-1	Activ8
K2613-XX	LN-25 PRO across-the-arc models
K4267-1	LN-25 PRO X
K4267-2	LN-25 PRO X with TVT (new wire feeder since launch of the Ranger 330MPX)
K3569-2	Magnum Pro 250 LX GT Spool gun with mechanical gas valve, Magnum Pro Consumables
STICK:	
K704	Stick welding kit with electrode holder, work clamp, 35' 2/0 cables, helmet, Electrode Holder. 400 amp nominal rating
K875	Stick welding kit with electrode cable 20 foot #6, work cable 15ft #6, electrode holder, work clamp and helmet. 150 amp nominal rating
K909-7	EH-305HD Heavy Duty Electrode Holder
K909-7	EH-405HD Heavy Duty Electrode Holder
K4345-1	CrossLinc Remote
K4330-1	remote control – 125 ft
K857	remote control – 25 ft
K4268-1	remote control – 125 ft with 115VAC receptacle
TIG:	
K870	Foot amptrol
K4217-1	Wireless pedal for TIG welding
K963-3	Hand amptrol
K930-2	TIG module
K936-3	TIG module cable, 9 pin to 6 pin + 115 VAC plug
K5126-1	Square Wave TIG 200
K2505-3	TIG Torch Twist-Mate to Stud adapter cable, 2 foot gas hose
K1783-9	PTA-26V TIG Torch with valve
K1782-9	PTA-17V TIG Torch with valve
KP509	TIG Parts kit
TRAILERS AND UNDERCARRIAGES:	
K2635-1	Small two-wheel road trailer with Duo Hitch
K2639-1	Fender and light kit
K2640-1	Cable Rack
K3589-1	Factory Undercarriage
K3590-1	All-terrain Undercarriage
K3591-1	Mounting Bracket and Mounting Band Kit
K3592-1	Gas Bottle Kit
ACCESSORIES:	
K586-1	Deluxe Adjustable Gas Regulator and Hose Kit
K3679-1	Spark arrestor
K802N	Power Plug Kit
K3588-1	Ranger Cover
K2149-1	Work Lead package (15 ft, 4/0) lug connector

ACCESSORIES AND OPTIONS

ACCESSORIES:	
K2150-1	Work lead package (15 ft, 2/0) lug connector
K1842-10	Weld power cable - lug to lug (3/0) - 10 foot
K2163-35	Weld power cable - lug to lug (4/0) - 35 ft (2 cables per package)
K2163-60	Weld power cable - lug to lug (4/0) - 60 ft (2 cables per package)
K2483-3	Weld cable - LC40HD male connector to open end (3/0) - 10 ft
K2485-3	Weld cable - LC40HD male connector to female connector (3/0) - 50 ft
K2484-3	Weld Cable - LC40HD male connector to lug (3/0) - 50 ft
K2487-1	Stud to Female Lenco adapter connector (CT-40FS)
K2946-1	Male Cam-Lok plug for 2/0 cable
K910-1	Work clamp, 300 amp
K910-2	Work clamp, 500 amp
K3416-70	Lenco male adapter
K3416-90	Lenco male adapter
K3417-70	Lenco female adapter
K3417-90	Lenco female adapter
K3494-1	Engine service parts kit (includes oil, oil filter, air filter and spark plugs)
K5322-1	Strain relief cable D ring kit

MAINTENANCE

SAFETY PRECAUTIONS

WARNING



Have qualified personnel do all maintenance and troubleshooting work.
Turn the engine off before working inside the machine or servicing the engine.
Remove guards only when necessary to perform maintenance and replace them when the maintenance requiring their removal is complete. If guards are missing from the machine, obtain replacements from a Lincoln Distributor. (See Operating Manual Parts List.)

Read the Safety Precautions in the front of this manual and in the Engine Owner's Manual before working on this machine.

Keep all equipment safety guards, covers, and devices in position and in good repair. Keep hands, hair, clothing, and tools away from the gears, fans, and all other moving parts when starting, operating, or repairing the equipment.

OIL AND OIL FILTER CHANGE

Turn the machine off. Drain the oil while the engine is warm to assure rapid and complete draining. See [Table 3 :NORMAL SERVICE INTERVALS](#) on page D-7 for capacity and service interval information.

- Remove the oil filler cap.
- Remove the cap from the drain valve. Push in and twist the yellow drain valve counter clockwise. Then pull the valve out and drain the oil into a suitable container.
- Close the valve by pushing in and twisting clockwise. Replace the cap. **Close valve and valve cap before adding oil and running the engine.**
- Remove the old oil filter. Use Channel Lock No. 209 pliers if the filter is stuck.
- Clean the oil filter mounting surface, and coat the new oil filter gasket with clean oil.
- Screw on the new oil filter by hand until the gasket touches the mounting surface. Then tighten the oil filter an additional 1/2 to 7/8 turn.
- Add oil until to the upper limit mark on the dipstick. Tighten the oil filler cap securely.
- Start the engine and check for leaks.
- Stop the engine and check the oil level. If necessary, add oil to the upper limit mark on the dipstick.

Use 4-stroke motor oil that meets or exceeds the requirements for API service classification SG or SH. SAE 10W-30 is recommended for general, all temperature use: -5°F to 104°F, -20°C to 40°C. See the Engine Owner's Manual for more specific information on oil viscosity recommendations.

Wash hands with soap and water after handling oil.

Dispose of used oil in a manner compatible with the environment. Do not throw used oil into the trash, pour it on the ground or down a drain.

AIR FILTER CHANGE

WARNING



Never use gasoline or low flash point solvents for cleaning the air cleaner element. A fire or explosion could result.

Never run the engine without the air cleaner. Rapid engine wear will result from contaminants such as dust and dirt being drawn into the engine.

Air Filter Pre-cleaner Service:

- Loosen the cover retaining knob and remove the cover.
- Remove the pre-cleaner from the paper element.
- Wash the pre-cleaner in warm water with detergent. Rinse the pre-cleaner thoroughly until all traces of detergent are removed. Squeeze out excess water (do not wring). Allow the pre-cleaner to dry.
- Reinstall the pre-cleaner over the paper element.
- Reinstall the air cleaner cover. Secure the cover with the cover retaining knob.

Air Filter Paper Element

- Loosen the cover retaining knob and remove the cover.
- Remove the pre-cleaner from the paper element.
- Remove the element cover nut, element cover, and paper element.
- Do not wash the paper element or use pressurized air, as this will damage the element. Replace a dirty, bent, or damaged element with a new element. Handle new elements carefully; do not use if the sealing surfaces are bent or damaged.
- When servicing the air cleaner, check the air cleaner base. Make sure it is secured and not bent or damaged. Also check the element cover for damaged or improper fit. Replace all damaged air cleaner components. Reinstall the paper element, pre-cleaner, element cover, element cover nut, and air cleaner cover. Secure cover with the cover retaining knob.

Note: Before air cleaner is reassembled make sure rubber seal is in position around stud. Inspect, making sure it is not damaged and seals with the element cover.

- Reinstall the paper element, pre-cleaner, element cover, element cover nut, and air cleaner cover. Secure cover with the cover retaining knob.

FUEL FILTER

WARNING



When working on the fuel system:

Keep naked lights away, do not smoke!

Do not spill fuel!

Check the fuel filter for water accumulation or sediment.

Replace the fuel filter if it is found with excessive water accumulation or sediment.

SPARK PLUG SERVICING

⚠ WARNING



Before removing spark plug, the muffler becomes very hot during operation and remains hot for a while after stopping the engine. Be careful not to touch the muffler while it is hot. The spark plug must be securely tightened. An improperly tightened spark plug can become very hot and may cause engine damage.

To ensure proper engine operation, the spark plug must be properly gapped and free of deposits.

- Remove the spark plug cap.
- Clean any dirt from around the spark plug base.
- Use a plug wrench to remove the spark plug.
- Visually inspect the spark plug. Discard them if the insulator is cracked or chipped. Clean the spark plug with a wire brush if it is to be reused.
- Measure the plug gap with a feeler gauge. Correct as necessary by bending the side electrode.
- Check that the spark plug washer is in good condition and thread the spark plug in by hand to prevent cross-threading.
- After the spark plug is seated, tighten with a spark plug wrench to compress the washer.
- If installing a new spark plug, tighten 1/2 turn after the spark plug seats to compress the washer.
- If reinstalling a used spark plug, tighten 1/8 - 1/4. turn after the spark plug seats to compress the washer.

Spark Plug Gap:	.030 in. (0.76 mm)
Spark Plug Torque:	20 ft. Lb. (27 N-m)

- Use only the recommended spark plug or equivalent.
- A spark plug which has an improper heat range may cause engine damage.

ENGINE SPEED ADJUSTMENT

⚠ WARNING



OVERSPEED IS HAZARDOUS

The maximum allowable high idle speed for this machine is 3750 RPM, no load. Do NOT tamper with governor components or setting or make any other adjustments to increase the maximum speed. Severe personal injury and damage to the machine can result if operated at speeds above maximum.

Adjustments to the engine are to be made only by a Lincoln Service Center or an authorized Field Service Shop.

BATTERY MAINTENANCE

WARNING



GASES FROM BATTERY can explode.
Keep sparks, flame and cigarettes away from battery.

WARNING



To prevent EXPLOSION when:
INSTALLING A NEW BATTERY — disconnect negative cable from old battery first and connect to new battery last.
CONNECTING A BATTERY CHARGER — remove battery from welder by disconnecting negative cable first, then positive cable and battery clamp. When reinstalling, connect Negative cable last. Keep well ventilated.
USING A BOOSTER — connect positive lead to battery first then connect negative lead to negative battery lead at engine foot.

WARNING



BATTERY ACID can burn eyes and skin.
Wear gloves and eye protection and be careful when working near battery.
Follow instructions printed on battery.

To access the battery, remove the 4 screws from the front battery cover. Slide the battery out only far enough to access the battery terminals.

CLEANING THE BATTERY: Keep the battery clean by wiping it with a damp cloth when dirty. If the terminals appear corroded, disconnect the battery cables and wash the terminals with an ammonia solution or a solution of 1/4 pound (0.11kg) of baking soda and 1 quart (0.1 L) of water. Be sure the battery vent plugs (if equipped) are tight so that none of the solution enters the cells.

After cleaning, flush the outside of the battery, the battery compartment, and surrounding areas with clear water. Coat the battery terminals lightly with petroleum jelly or a non-conductive grease to retard corrosion. Keep the battery clean and dry. Moisture accumulation on the battery can lead to more rapid discharge and early battery failure.

CHECKING THE ELECTROLYTE LEVEL If battery cells are low, fill them to the neck of the filler hole with distilled water and recharge. If one cell is low, check for leaks.

CHARGING THE BATTERY When you charge, jump, replace, or otherwise connect battery cables to the battery, be sure the polarity is correct. Improper polarity can damage the charging circuit. The Ranger positive (+) battery terminal has a red terminal cover.

If you need to charge the battery with an external charger, disconnect the negative cable first, then the positive cable before you attach the charger leads. After the battery is charged, reconnect the positive battery cable first and the negative cable last. Failure to do so can result in damage to the internal charger components. Follow the instructions of the battery charger manufacturer for proper charger settings and charging time.

SPARK ARRESTOR SERVICING

 WARNING	
	<p>Muffler may be hot.</p> <p>Allow the engine to cool before installing the spark arrestor.</p> <p>Do not operate the engine while installing the spark arrestor.</p>

Clean every 100 hours.

STORAGE



To prepare the engine for long term storage, run the fuel purge routine in the Set-up Menu.

Store the Ranger in a clean, dry, protected location.

WELDER GENERATOR MAINTENANCE

Blow out the generator and controls periodically with low pressure compressed air.

BRUSH REMOVAL AND REPLACEMENT

 WARNING	
	<p>Do not attempt to polish slip rings while the engine is running.</p> <p>Service and repair should only be performed by Lincoln Electric Factory Trained Personnel. Unauthorized repairs may result in danger to the technician and machine operator and will invalidate your factory warranty. For your safety and to avoid Electric Shock, please observe all safety notes and precautions.</p>

It is normal for the brushes and slip rings to wear and darken slightly. Inspect the brushes every 3 months or 200 hours, whichever comes first.

To replace the brush for code 12646 and codes 13011 and higher:

1. Shut off power to the machine.

MAINTENANCE

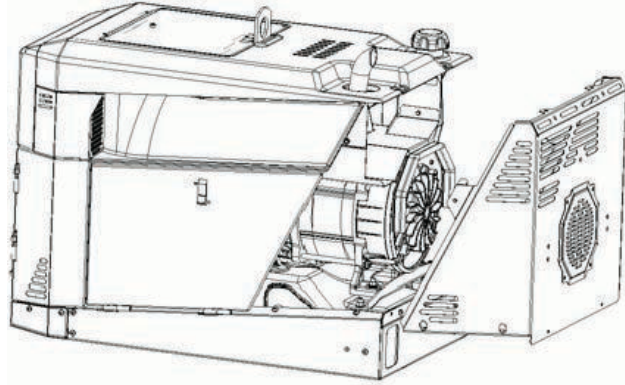

2. Using a T-30 Torx bit, remove the 8 screws securing the case back and remove the case back.
3. Using a 5/8" socket and impact wrench, remove the rotor through bolt and then remove the rear alternator fan. Note there is Loctite on the rotor through bolt.

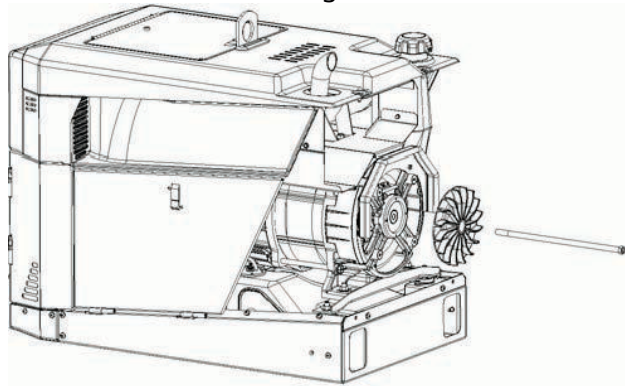

4. Remove leads 200 and 219 from the brush holder.
5. Using a 10mm wrench, remove the two screws securing the brush holder assembly. Lift the brush holder assembly up and then out.

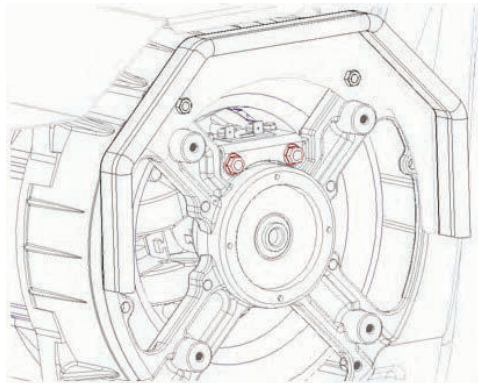

6. Examine the brushes for chips, cracks or excess or uneven wear. The brush should be at least .75" long. Verify the brush springs are operating and are not stuck. Replace the brush assembly as needed. Inspect the rotor slip rings for grooves or excess wear.
7. Before reassembling the brush holder, confirm the rotor is pushed up against the engine. The rotor bearing should be inset of the end of the casting.

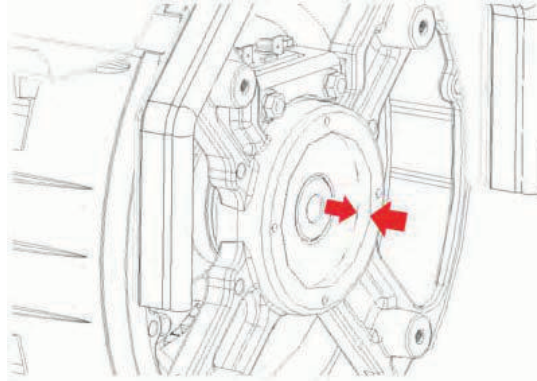

8. Reassemble the brush holder assemble and tighten the bolts to 41 in-lbs.
9. Connect leads 200 and 219 to the brush holder.
10. Apply a small amount of "red" Loctite 271 or equivalent to the threads of the rotor bolt, and assemble the fan and rotor bolt. Tighten to 50 ft-lbs.
11. Reassemble the case back.

NORMAL SERVICE INTERVALS

Table 3 :NORMAL SERVICE INTERVALS

ITEM	SERVICE INTERVAL	REPLACEMENT PART NUMBER	PART OF K3494-1 SERVICE KIT
OIL AND OIL FILTER	5 hours for first oil change	2.0 qts 10W-30 for general use (-5°F to 104°F, -20°C to 40°C)	Y
	100 hours	Rhelko 12 050 01 Oil Filter	
AIR FILTER	100 hours	Rhelko 24 083 03 Air Filter Element Rhelko 24 083 02 Air Filter Pre-Cleaner	Y
SPARK PLUG	500 hours	Champion RC12YC (.030" gap)	Y
FUEL FILTER	200 hours	Rhelko 24 050 13	Y
BRUSHES	1000 hours	Lincoln G9084-C	N

TROUBLESHOOTING

HOW TO USE TROUBLESHOOTING GUIDE

WARNING



Service and Repair should only be performed by Lincoln Electric Factory Trained Personnel. Unauthorized repairs performed on this equipment may result in danger to the technician and machine operator and will invalidate your factory warranty. For your safety and to avoid Electrical Shock, please observe all safety notes and precautions detailed throughout this manual.

This Troubleshooting Guide is provided to help you locate and repair possible machine malfunctions. Simply follow the three-step procedure listed below.

1. LOCATE PROBLEM (SYMPTOM)

Look under the column labeled "PROBLEM (SYMPTOMS)". This column describes possible symptoms that the machine may exhibit. Find the listing that best describes the symptom that the machine is exhibiting.

2. POSSIBLE CAUSE

The second column labeled "POSSIBLE CAUSE" lists the obvious external possibilities that may contribute to the machine symptom.

3. RECOMMENDED COURSE OF ACTION

This column provides a course of action for the Possible Cause, generally it states to contact your local Lincoln Authorized Field Service Facility.

CAUTION



If you do not understand or are unable to perform the Recommended Course of Action safely, contact your local Lincoln Authorized Field Service Facility.

Observe all additional safety guidelines detailed throughout this manual.

TROUBLESHOOTING GUIDE

Observe all Safety Guidelines detailed throughout this manual

PROBLEMS (SYMPTOMS)	POSSIBLE CAUSE	RECOMMENDED COURSE OF ACTION
AUXILIARY OUTPUT PROBLEMS		

TROUBLESHOOTING

PROBLEMS (SYMPTOMS)	POSSIBLE CAUSE	RECOMMENDED COURSE OF ACTION
No 120 VAC output.	<ol style="list-style-type: none"> 1. Check that the 20 Amp circuit breaker did not trip. 2. Check that the 50 amp breaker did not trip. 3. Check that the GFCI has not reset. 4. Inspect the alternator brushes for wear or corrosion on the slip rings. 5. Faulty pc board. 	If all recommended possible areas of misadjustment have been checked and the problem persists, Contact your local Lincoln Authorized Field Service Facility.
No 120 VAC and no 240 VAC output.	<ol style="list-style-type: none"> 1. Check that the 50 amp breaker did not trip. 2. Inspect the alternator brushes for wear or corrosion on the slip rings. 3. Check flashing diode. 4. Faulty pc board. 	If all recommended possible areas of misadjustment have been checked and the problem persists, Contact your local Lincoln Authorized Field Service Facility.
PROBLEMS (SYMPTOMS)	POSSIBLE CAUSE	RECOMMENDED COURSE OF ACTION
ENGINE PROBLEMS		
Engine will not crank.	<ol style="list-style-type: none"> 1. Low or weak battery. 2. Inspect for loose or corroded battery terminals. 3. "Battery circuit" circuit breaker (CB4) has tripped. 4. Faulty starter motor. 5. Check starter terminals for loose or missing wires. 6. Check start switch wires for positive connection. 	If all recommended possible areas of misadjustment have been checked and the problem persists, Contact your local Lincoln Authorized Field Service Facility.
Engine will crank but not start.	<ol style="list-style-type: none"> 1. Out of fuel. 2. Check choke operation. 3. The machine was in a sleep mode. Place the OFF/ IDLE/RUN/START switch in the OFF position for 10 seconds and then restart. 4. Enter correct security PIN if the PIN is enabled. 5. Fuel pump not working. 6. Ensure spark plug wires and spark plugs are in good shape and installed properly. 7. Bad coil, remove spark plug and check for spark. 8. Low oil pressure sensor is loose or not working. 	If all recommended possible areas of misadjustment have been checked and the problem persists, Contact your local Lincoln Authorized Field Service Facility.

PROBLEMS (SYMPTOMS)	POSSIBLE CAUSE	RECOMMENDED COURSE OF ACTION
Engine shuts down shortly after starting.	<ol style="list-style-type: none"> 1. Low fuel level. 2. Low oil level. 3. Clogged fuel filter. Clean. 4. Faulty oil pressure switch. 5. Faulty fuel pump. 	If all recommended possible areas of misadjustment have been checked and the problem persists, Contact your local Lincoln Authorized Field Service Facility.
Engine has low output or runs rough.	<ol style="list-style-type: none"> 1. Low fuel. 2. Clogged fuel filter. 3. Clogged air filter. 4. Choke is stuck. 5. Poor quality fuel – fuel has sat for a long time. 6. Spark plugs are fouled, or plug wires are loose. 7. Valves are out of adjustment. 8. Verify the correct fuel cap is being used. 	If all recommended possible areas of misadjustment have been checked and the problem persists, Contact your local Lincoln Authorized Field Service Facility.
Engine will not go to low idle.	<ol style="list-style-type: none"> 1. Idler switch is in the High Idle position. 2. Aux load might be on. 3. Idle solenoid and or wiring needs checked or replaced. 4. Faulty pc board. 	If all recommended possible areas of misadjustment have been checked and the problem persists, Contact your local Lincoln Authorized Field Service Facility.
Engine does not go to full power when using auxiliary power.	<ol style="list-style-type: none"> 1. The auxiliary power load is less than 100 Watts. Set the STOP/AUTO/HIGH IDLE switch to HIGH IDLE. 2. Disconnect / turn off auxiliary power loads before starting the engine. 	If all recommended possible areas of misadjustment have been checked and the problem persists, Contact your local Lincoln Authorized Field Service Facility.
PROBLEMS (SYMPTOMS)	POSSIBLE CAUSE	RECOMMENDED COURSE OF ACTION
WELDING PROBLEMS		

TROUBLESHOOTING

PROBLEMS (SYMPTOMS)	POSSIBLE CAUSE	RECOMMENDED COURSE OF ACTION
No weld output.	<ol style="list-style-type: none"> 1. Verify the weld output is ON. A green icon with "Output ON" appears in the upper right corner of screen whenever weld output is ON. 2. Verify the work connection is tight and attached to clean base metal. 3. The duty cycle of the machine was exceeded and the machine overheated. Allow the machine to cool", "inspect alternator brushes", "verify voltage feedback wiring to the pc board. 4. Faulty pc board. 	<p>If all recommended possible areas of misadjustment have been checked and the problem persists, Contact your local Lincoln Authorized Field Service Facility.</p>
No output control – at the front panel.	<ol style="list-style-type: none"> 1. Verify the remote control is not turned on. "Remote ON" appears on the bottom left of the screen whenever the remote is turned on. 2. A CrossLinc device is attached to the machine. The CrossLinc symbol appears on the right side of the screen when CrossLinc is active. 3. Faulty encoder. 	<p>If all recommended possible areas of misadjustment have been checked and the problem persists, Contact your local Lincoln Authorized Field Service Facility.</p>
No output control – with remote.	<ol style="list-style-type: none"> 1. Check the remote cable and connection to the 6 pin connector. 2. Verify the remote control is turned on. "Remote ON" appears on the bottom left of the screen whenever the remote is turned on. 3. A CrossLinc device is attached to the machine. The CrossLinc symbol appears on the right side of the screen when CrossLinc is active. 4. The remote range has been adjusted so the minimum and maximum values are the same. 	<p>If all recommended possible areas of misadjustment have been checked and the problem persists, Contact your local Lincoln Authorized Field Service Facility.</p>
Output control range is limited while using a remote.	<ol style="list-style-type: none"> 1. While in the weld mode, go to the remote screen and change the scaling of the remote. 	<p>If all recommended possible areas of misadjustment have been checked and the problem persists, Contact your local Lincoln Authorized Field Service Facility.</p>

PROBLEMS (SYMPTOMS)	POSSIBLE CAUSE	RECOMMENDED COURSE OF ACTION
The arc is not stable.	<ol style="list-style-type: none"> 1. Verify the polarity of the electrode and work cables. 2. Cables may be excessively long, undersized or damaged. 3. Verify the weld settings match the electrode. Use Ready-Set-Weld, menu for guidance. 	If all recommended possible areas of misadjustment have been checked and the problem persists, Contact your local Lincoln Authorized Field Service Facility.

 **CAUTION**



If for any reason you do not understand the test procedures or are unable to perform the tests/repairs safely, contact your **Local Lincoln Authorized Field Service Facility** for technical troubleshooting assistance before you proceed.

WIRING DIAGRAM - G9203

For use with codes: 12646, 13011, 13648, 13651, 13804, & 13805

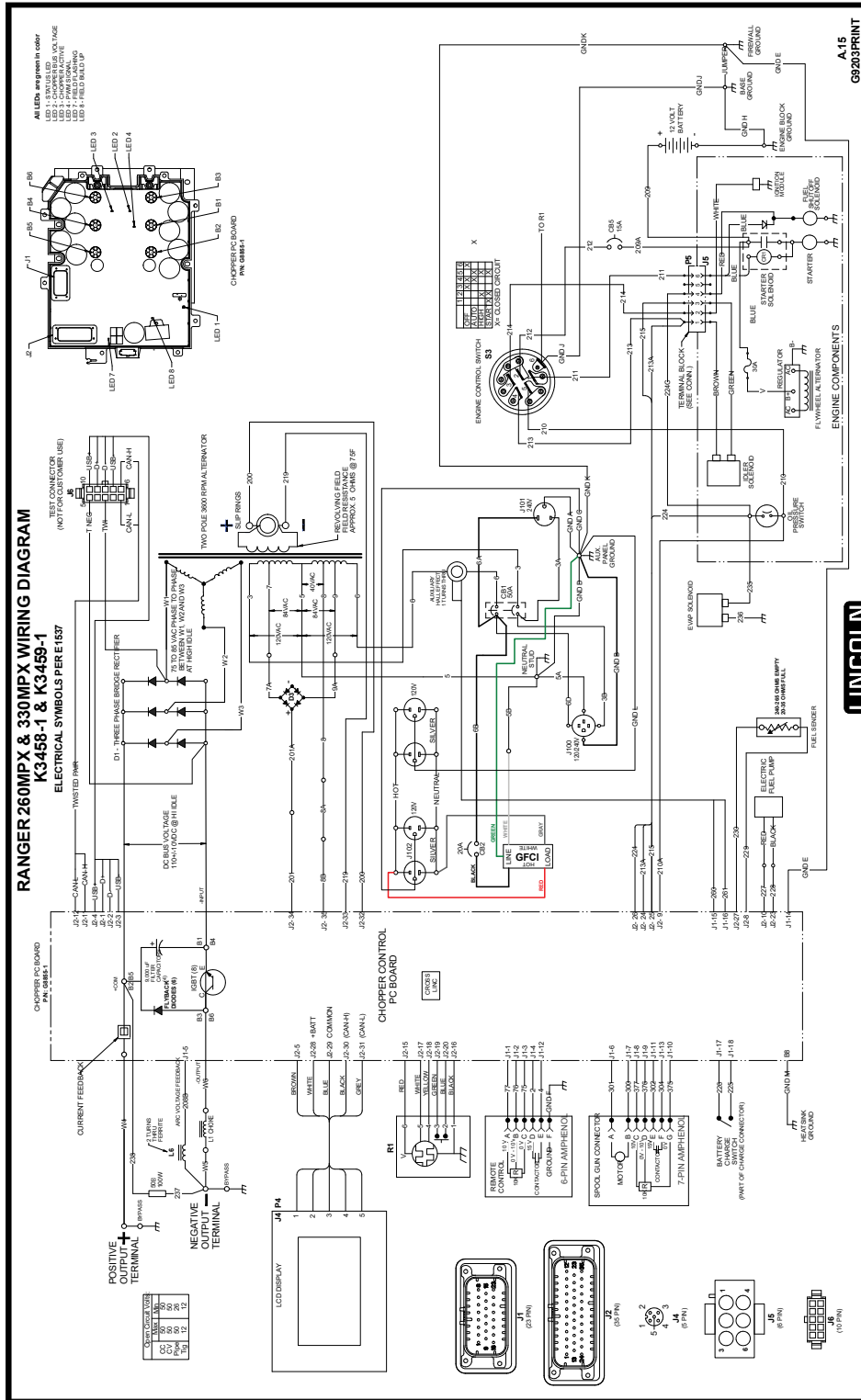

WIRING DIAGRAM - G9203

For use with codes: 12646, 13011, 13648, 13651, 13804, & 13805

RANGER 260MPX & 330MPX WIRING DIAGRAM Page 1 of 2 K3458-1 & K3459-1 ELECTRICAL SYMBOLS PER E1537

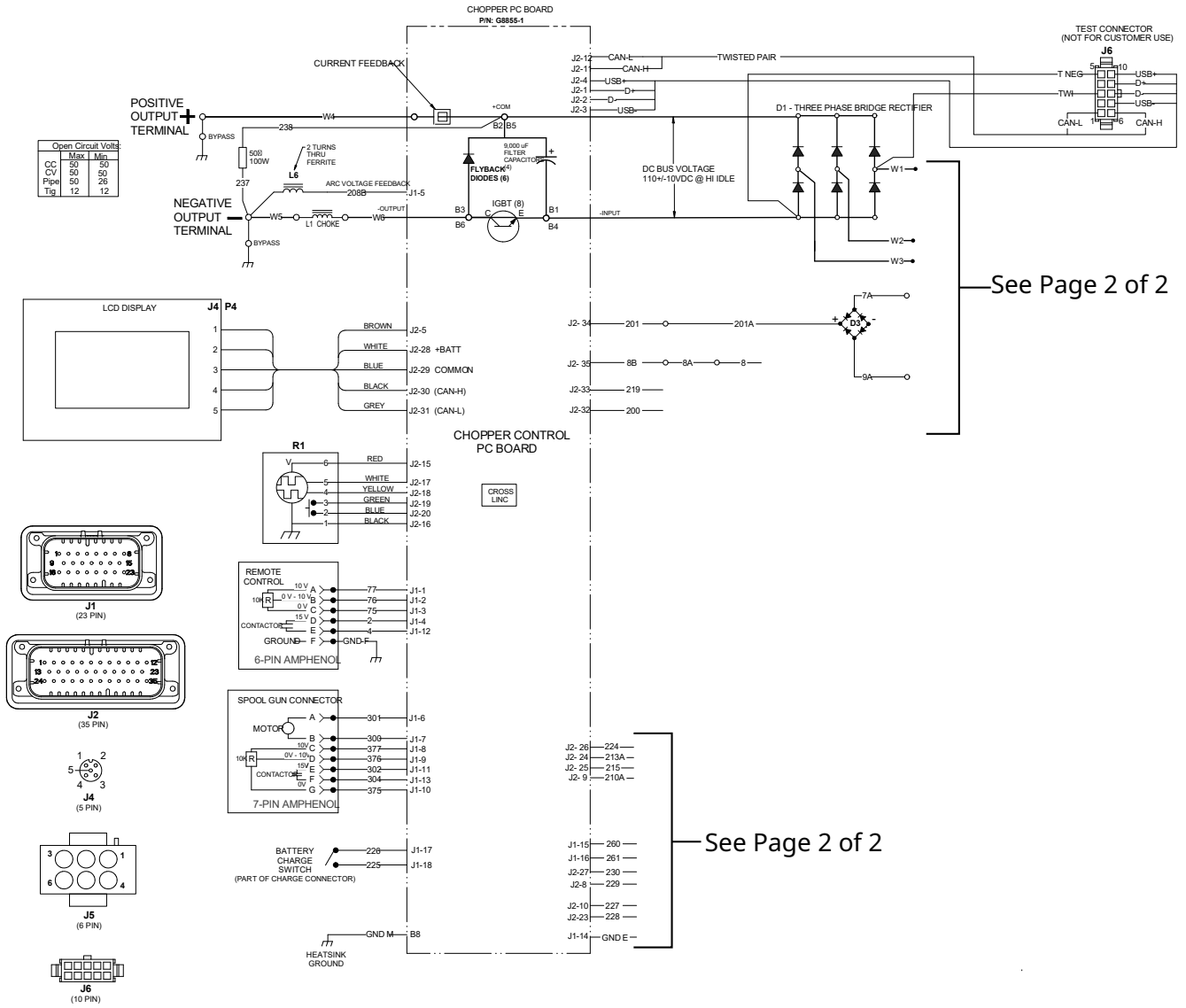

See Page 2 of 2

See Page 2 of 2

A.15
G9203PRINT

RANGER 260MPX & 330MPX WIRING DIAGRAM Page 2 of 2
K3458-1 & K3459-1
 ELECTRICAL SYMBOLS PER E1537

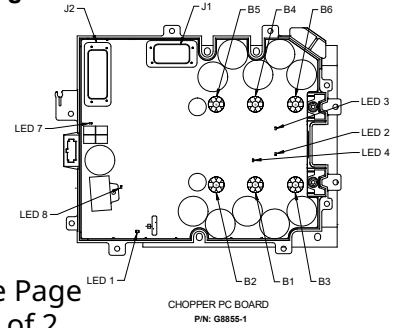

All LEDs are green in color
 LED 1 - STAT US LED
 LED 2 - CHOPPER BUS VOLTAGE
 LED 3 - CHOPPER ACTIVE
 LED 4 - PWM SIGNAL
 LED 7 - FIELD FLASHING
 LED 8 - FIELD BUILD UP

See Page 1 of 2

See Page 1 of 2

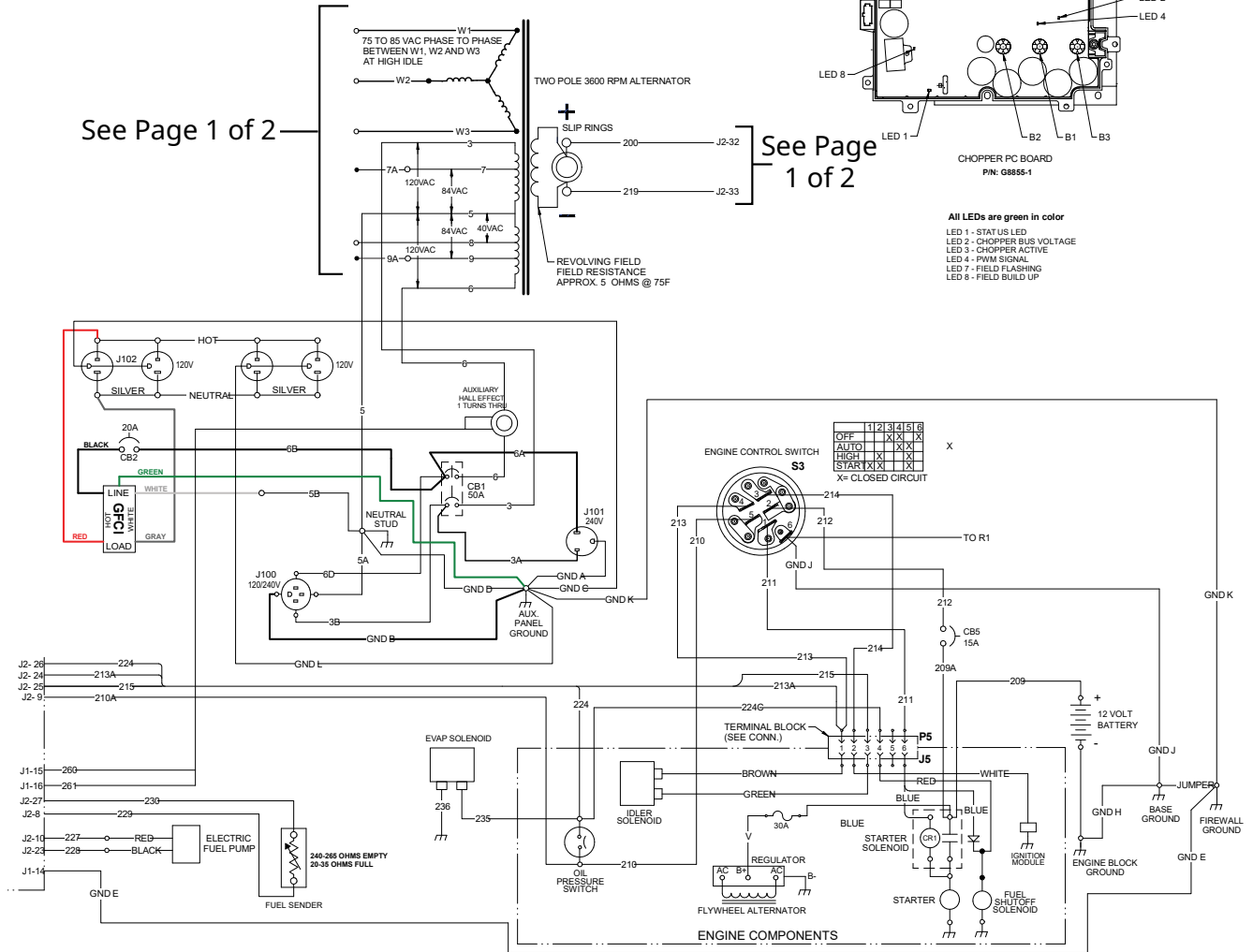

A.15
 G9203PRINT

DIMENSIONS

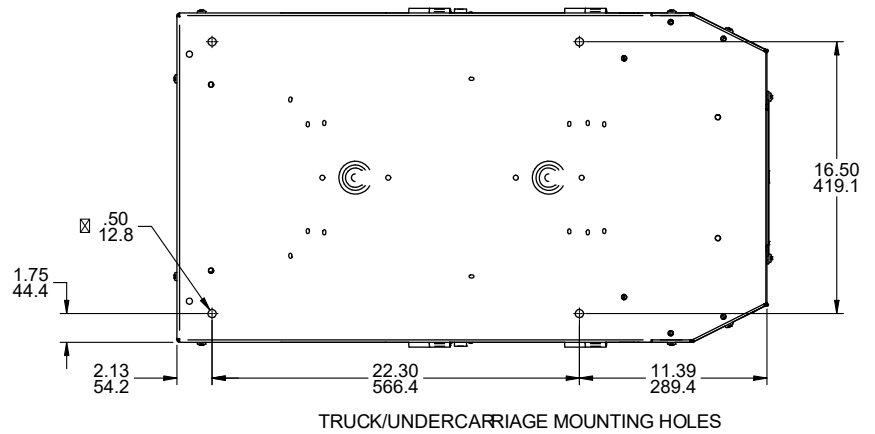
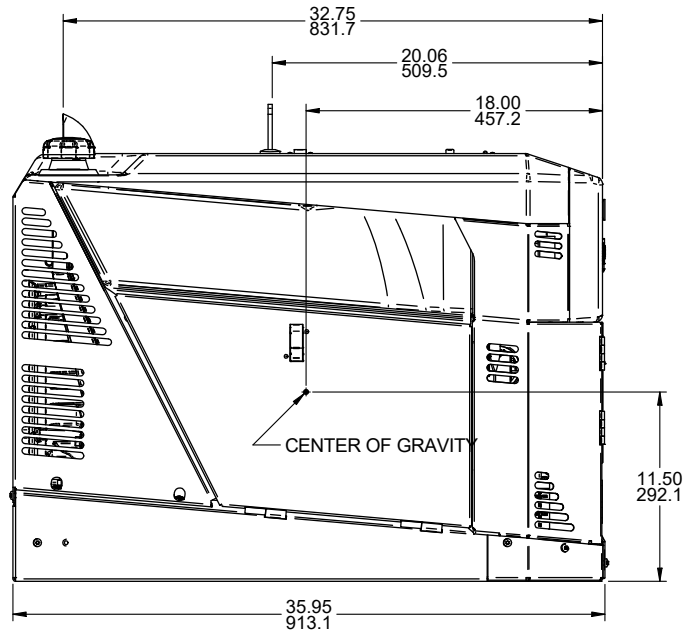
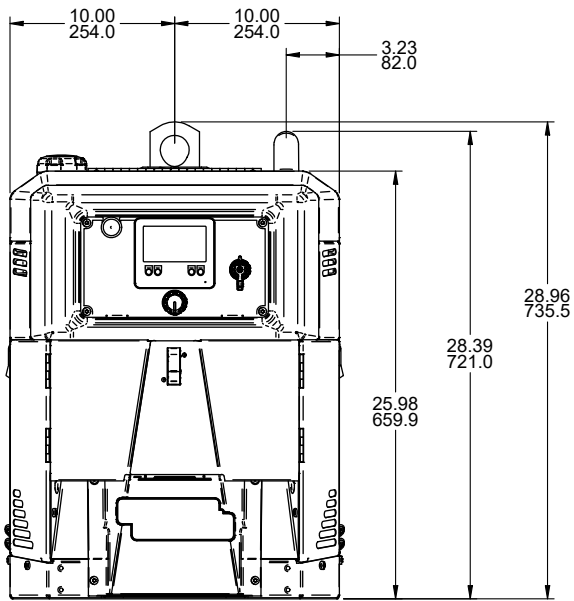

CUSTOMER ASSISTANCE POLICY

CUSTOMER ASSISTANCE POLICY

The business of Lincoln Electric is manufacturing and selling high quality welding equipment, automated welding systems, consumables, and cutting equipment. Our challenge is to meet the needs of our customers, who are experts in their fields, and to exceed their expectations. On occasion, purchasers may ask Lincoln Electric for information or technical information about their use of our products. Our employees respond to inquiries to the best of their ability based on information and specifications provided to them by the customers and the knowledge they may have concerning the application. Our employees, however, are not in a position to verify the information provided or to evaluate the engineering requirements for the particular weldment, or to provide engineering advice in relation to a specific situation or application. Accordingly, Lincoln Electric does not warrant or guarantee or assume any liability with respect to such information or communications. Moreover, the provision of such information or technical information does not create, expand, or alter any warranty on our products. Any express or implied warranty that might arise from the information or technical information, including any implied warranty of merchantability or any warranty of fitness for any customers' particular purpose or any other equivalent or similar warranty is specifically disclaimed.

Lincoln Electric is a responsive manufacturer, but the definition of specifications, and the selection and use of specific products sold by Lincoln Electric is solely within the control of, and remains the sole responsibility of the customer. Many variables beyond the control of Lincoln Electric affect the results obtained in applying these types of fabrication methods and service requirements.

WELD FUME CONTROL EQUIPMENT

The operation of welding fume control equipment is affected by various factors including proper use and positioning of the equipment, maintenance of the equipment and the specific welding procedure and application involved. Worker exposure level should be checked upon installation and periodically thereafter to be certain it is within applicable OSHA PEL and ACGIH TLV limits.

PARTS LIST

Content/Details may be changed or updated without notice. For most current Instruction Manuals, go to PARTS.LINCOLNELECTRIC.COM.

